

# BID PROPOSAL

## BID BOND

KNOW ALL MEN BY THESE PRESENTS, that I/We Houston Smith Construction, Inc.  
as Principal, hereinafter called Contractor, and The Ohio Casualty Insurance Company  
a corporation duly organized under the laws of the State of Nevada, as Surety, hereinafter called the Surety, are held and  
firmly bound unto Carson City, Nevada a consolidated municipality of the State of Nevada, hereinafter called City, for the sum  
of \$ 5% of total bid-----Dollars  
(state sum in words) Five percent of the total amount bid-----  
for the payment whereof Contractor and Surety bind themselves, their heirs, executors, administrators, successors and  
assigns, jointly and severally, firmly by these presents.

WHEREAS, the Principal has submitted a bid, identified as BID # 1314-155 and titled "Fairgrounds Arena Picnic Shelter  
Project".

NOW, THEREFORE if the City shall accept the bid of the Principal and the Principal shall enter into a contract with the City in  
accordance with the terms of such bid, and give such bond or bonds as may be specified in the bidding or Bid Documents with  
good and sufficient surety for the faithful performance of such Contract and for the prompt payment of labor and material  
furnished in the prosecution thereof, or in the event of the failure of the Principal to enter such Contract and give such bond or  
bonds, if the Principal shall pay to the City the difference not to exceed the penalty hereof between the amount specified in  
said bid and such larger amount for which the City may in good faith contract with another party to perform work covered by  
said bid or an appropriate liquidated amount as specified in the Invitation for Bids then this obligation shall be null and void,  
otherwise to remain in full force and effect.

Executed on this 11th day of February 2014

Signature of Principal: [Signature]

Title: President

Firm: Houston Smith Construction, Inc.

Address: 4010 Drake Way

City/State/Zip Code: Carson City, NV 89704

Written Name of Principal: Rollin Smith

ATTEST NAME

Signature of Notary: [Signature]

(Seal)

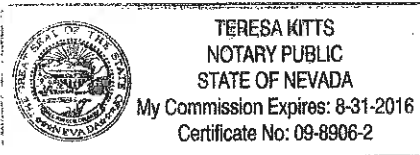

Subscribed and sworn before me this 20th day of February 2014

(printed name of notary) Teresa Kitts Notary Public for the State of Nevada

Claims Under this Bond May be Addressed to: Nevada Resident Agent Information  
Complete for out of state bonding companies

Name of Surety The Ohio Casualty Insurance Co.

Address 16505 SW 72nd Ave. Bldg. F

City Portland

State/Zip Code OR, 97224

Name [Signature] Robert W. Lagler

Title Attorney-in-Fact

Phone 360-892-5840

Surety's Acknowledgement See attached

Name of Local Agent Phoenix Surety & Insurance Agency

Address 1499 SE Tech Center Pl. #150

City Vancouver

State/Zip Code WA, 98683

Agent's Name Robert W. Lagler

Agent's Title Non-Resident Agent

Agents Phone 360-892-5840

NOTICE: No substitution or revision to this bond form will be accepted. Sureties must be authorized to do  
business in and have an agent for services of process in the State of Nevada. Certified copy of Power of Attorney  
must be attached.

ACKNOWLEDGMENT BY SURETY

STATE OF Washington  
County of Clark } ss.

On this 11th day of February, 2014, before me personally  
appeared Robert W. Lagler, known to, me to be the Attorney-in-Fact of  
The Ohio Casualty Insurance Company

\_\_\_\_\_, the corporation  
that executed the within instrument, and acknowledged to me that such corporation executed the same.

IN WITNESS WHEREOF, I have hereunto set my hand and affixed my official seal, at my office in the aforesaid County, the day and  
year in this certificate first above written.

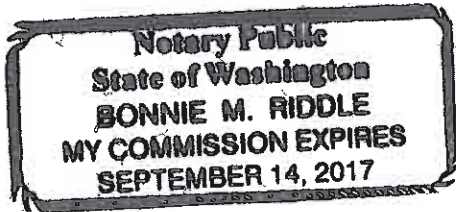

Notary Public in the State of Washington  
County of Clark



**THIS POWER OF ATTORNEY IS NOT VALID UNLESS IT IS PRINTED ON RED BACKGROUND.**

This Power of Attorney limits the acts of those named herein, and they have no authority to bind the Company except in the manner and to the extent herein stated.

Certificate No. 6338382

American Fire and Casualty Company  
The Ohio Casualty Insurance Company

Liberty Mutual Insurance Company  
West American Insurance Company

**POWER OF ATTORNEY**

KNOWN ALL PERSONS BY THESE PRESENTS: That American Fire & Casualty Company and The Ohio Casualty Insurance Company are corporations duly organized under the laws of the State of New Hampshire, that Liberty Mutual Insurance Company is a corporation duly organized under the laws of the State of Massachusetts, and West American Insurance Company is a corporation duly organized under the laws of the State of Indiana (herein collectively called the "Companies"), pursuant to and by authority herein set forth, does hereby name, constitute and appoint Bonnie Riddle; Janice A. Lewton; Robert W. Lagler

all of the city of VANCOUVER, state of WA each individually if there be more than one named, its true and lawful attorney-in-fact to make, execute, seal, acknowledge and deliver, for and on its behalf as surety and as its act and deed, any and all undertakings, bonds, recognizances and other surety obligations, in pursuance of these presents and shall be as binding upon the Companies as if they have been duly signed by the president and attested by the secretary of the Companies in their own proper persons.

IN WITNESS WHEREOF, this Power of Attorney has been subscribed by an authorized officer or official of the Companies and the corporate seals of the Companies have been affixed thereto this 5th day of November, 2013.



STATE OF WASHINGTON ss  
COUNTY OF KING

On this 5th day of November, 2013, before me personally appeared Gregory W. Davenport, who acknowledged himself to be the Assistant Secretary of American Fire and Casualty Company, Liberty Mutual Insurance Company, The Ohio Casualty Company, and West American Insurance Company, and that he, as such, being authorized so to do, execute the foregoing instrument for the purposes therein contained by signing on behalf of the corporations by himself as a duly authorized officer.

IN WITNESS WHEREOF, I have hereunto subscribed my name and affixed my notarial seal at Seattle, Washington, on the day and year first above written.



American Fire and Casualty Company  
The Ohio Casualty Insurance Company  
Liberty Mutual Insurance Company  
West American Insurance Company  
By: Gregory W. Davenport  
Gregory W. Davenport, Assistant Secretary

By: KD Riley  
KD Riley, Notary Public

This Power of Attorney is made and executed pursuant to and by authority of the following By-laws and Authorizations of American Fire and Casualty Company, The Ohio Casualty Insurance Company, Liberty Mutual Insurance Company, and West American Insurance Company which resolutions are now in full force and effect reading as follows:

**ARTICLE IV - OFFICERS** - Section 12. Power of Attorney. Any officer or other official of the Corporation authorized for that purpose in writing by the Chairman or the President, and subject to such limitation as the Chairman or the President may prescribe, shall appoint such attorneys-in-fact, as may be necessary to act in behalf of the Corporation to make, execute, seal, acknowledge and deliver as surety any and all undertakings, bonds, recognizances and other surety obligations. Such attorneys-in-fact, subject to the limitations set forth in their respective powers of attorney, shall have full power to bind the Corporation by their signature and execution of any such instruments and to attach thereto the seal of the Corporation. When so executed, such instruments shall be as binding as if signed by the President and attested to by the Secretary. Any power or authority granted to any representative or attorney-in-fact under the provisions of this article may be revoked at any time by the Board, the Chairman, the President or by the officer or officers granting such power or authority.

**ARTICLE XIII - Execution of Contracts** - SECTION 5. Surety Bonds and Undertakings. Any officer of the Company authorized for that purpose in writing by the chairman or the president, and subject to such limitations as the chairman or the president may prescribe, shall appoint such attorneys-in-fact, as may be necessary to act in behalf of the Company to make, execute, seal, acknowledge and deliver as surety any and all undertakings, bonds, recognizances and other surety obligations. Such attorneys-in-fact subject to the limitations set forth in their respective powers of attorney, shall have full power to bind the Company by their signature and execution of any such instruments and to attach thereto the seal of the Company. When so executed such instruments shall be as binding as if signed by the president and attested by the secretary.

**Certificate of Designation** - The President of the Company, acting pursuant to the Bylaws of the Company, authorizes Gregory W. Davenport, Assistant Secretary to appoint such attorneys-in-fact as may be necessary to act on behalf of the Company to make, execute, seal, acknowledge and deliver as surety any and all undertakings, bonds, recognizances and other surety obligations.

**Authorization** - By unanimous consent of the Company's Board of Directors, the Company consents that facsimile or mechanically reproduced signature of any assistant secretary of the Company, wherever appearing upon a certified copy of any power of attorney issued by the Company in connection with surety bonds, shall be valid and binding upon the Company with the same force and effect as though manually affixed.

I, David M. Carey, the undersigned, Assistant Secretary, of American Fire and Casualty Company, The Ohio Casualty Insurance Company, Liberty Mutual Insurance Company, and West American Insurance Company do hereby certify that the original power of attorney of which the foregoing is a full, true and correct copy of the Power of Attorney executed by said Companies, is in full force and effect and has not been revoked.

IN TESTIMONY WHEREOF, I have hereunto set my hand and affixed the seals of said Companies this 15th day of February, 2014.



By: David M. Carey  
David M. Carey, Assistant Secretary

Not valid for mortgage, note, loan, letter of credit, currency rate, interest rate or residual value guarantees.

To confirm the validity of this Power of Attorney call 1-610-832-8240 between 9:00 am and 4:30 pm EST on any business day.

# BID PROPOSAL

**BID # 1314-155**

**BID TITLE: "Fairgrounds Arena Picnic Shelter Project"**

**NOTICE:** No substitution or revision to this Bid Proposal form will be accepted. Carson City will reject any Bid that is received that has changes or alterations to this document. Although the Prevailing Wages are provided in this bid document, the bidder is responsible to verify with the Labor Commissioner if any addendums have been issued. The successful bidder will be required to provide the current Prevailing Wages used in preparation of their bid within 24 hours of bid submission.

**PRICES** will be valid for sixty (60) calendar days after the bid opening which is indicated in the Notice to Contractors.

**A COPY OF CONTRACTOR'S "CERTIFICATE"** of eligibility issued by the State of Nevada Contractors' Board as proof of Bidder's compliance with the provisions of N.R.S. 338.147 must be submitted with his/her bid for the preference to be considered. This Statute does not apply to projects expected to cost less than \$250,000.

**COMPLETION** of this project is expected **PURSUANT TO THE BID DOCUMENTS.**

**BIDDER** acknowledges receipt of 1 Addendums.

**SUMMARY**

Description		Scheduled Value	Unit	Unit Price	Total Price
<b>Schedule A: Base bid Items</b>					
BP. 1	Mobilization, Demobilization and Clean-up (SC 4.3.2)	1	LS	15,000	15,000 <sup>-</sup>
BP. 2	Picnic Shelter (SC 4.3.3)	1	LS	64,000	64,000 <sup>-</sup>
BP. 3	Access Ramp (SC 4.3.4)	1	LS	5,200	5,200 <sup>-</sup>
BP. 4	Concrete Flatwork (SC 4.3.5)	2,782	SF	7.25	20,169.50
BP. 5	Electrical Conduits, Irrigation Sleeves, and Electrical Pull-boxes (SC 4.3.6)	1	LS	2,075	2,075 <sup>-</sup>
<b>Subtotal: Schedule A</b>					
BP. 6	<b>Total Base Bid Price (Schedule A)</b>			<b>\$106,444.50</b>	

**BP.7** Total Base (Schedule A) Bid Price Written in Words:

one hundred six thousand four hundred forty four dollars + fifty cents      1



# BID PROPOSAL

## BP.8 BIDDER INFORMATION:

Company Name:	Houston Smith Construction, Inc.
Federal ID No.:	20-2889474.
Mailing Address:	4010 Drake Way.
City, State, Zip Code:	Carson City, NV. 89704.
Complete Telephone Number:	(775) 849-1802
Complete Fax Number:	(775) 546-6255
Fax Number including area code:	(775) 546-6255
E-mail:	rollin@houstonsmithinc.com

Contact Person / Title:	Rollin Smith / President
Mailing Address:	4010 Drake Way.
City, State, Zip Code:	Carson City, NV. 89704
Complete Telephone Number:	(775) 750-0203
Complete Fax Number:	(775) 546-6255
E-mail Address:	rollin@houstonsmithinc.com

## BP.9 LICENSING INFORMATION:

Nevada State Contractor's License Number:	70322
License Classification(s):	B - General Building
Limitation(s) of License:	\$700,000-
Date Issued:	2-01-08
Date of Expiration:	2/29/16.
Name of Licensee:	Houston Smith Construction, Inc.
Carson City Business License Number:	14-00022626.
Date Issued:	1-13-14
Date of Expiration:	12-31-14
Name of Licensee:	Houston Smith Construction, Inc.

# BID PROPOSAL

## BP.10 DISCLOSURE OF PRINCIPALS:

### Individual and/or Partnership:

Owner 1) Name:	Rollin Smith
Address:	4010 Drake Way.
City, State, Zip Code:	Carson City, NV. 89704
Telephone Number:	(775) 750-0203
Owner 2) Name:	
Address:	
City, State, Zip Code:	
Telephone Number:	
Other 1) Title:	
Name	
Other 2) Title:	
Name:	

### Corporation:

State in which Company is Incorporated:	Nevada
Date Incorporated:	May 13, 2005.
Name of Corporation:	Houston Smith Construction, Inc.
Mailing Address	4010 Drake Way.
City, State, Zip Code:	Carson City, NV. 89704.
Telephone Number:	(775) 849-1802
President's Name:	Rollin Smith
Vice-President's Name:	Rollin Smith
Other 1) Name & Title:	

# BID PROPOSAL

## BP.11 MANAGEMENT AND SUPERVISORY PERSONNEL:

Persons and Positions	Years With Firm
Name 1) Rollin Smith / Project Manager	9 years.

Title 1)

Name 2) Juan Brena / Supervisor	6 years.
---------------------------------	----------

Title 2)

Name 3) Teresa Kotts / office / Project manager	6 years.
---	----------

Title 3)

Name 4) Oscar San Vicente / Foreman	1 year.
-------------------------------------	---------

Title 4)

Name 5)	
---------	--

Title 5)

Name 6)	
---------	--

Title 6)

(If additional space is needed, attach a separate page)

# BID PROPOSAL

**BP.12 REFERENCES:**

**Instructions:**

List at least three (3) contracts of a similar nature performed by your firm in the last three (3) years. If **NONE**, use your Company's letterhead (and submit with your bid proposal) to list what your qualifications are for this contract. Carson City reserves the right to contact and verify, with any and all references listed, the quality of and the degree of satisfaction for such performance.

**Clients:** (if additional space is needed attach a separate page)

Company Name 1): Washoe County
Contract Person: Gerry Bayfield
Mailing Address: 1001 East Ninth Street. PO Box 11130
City, State, Zip Code: Reno, NV. 89520-0027.
Complete Telephone Number: 775-328-2040
E-Mail Address: gbayfield@washoecounty.us
Project Title: Washoe County Animal Shelter Shade Structure
Amount of Contract: 22,920-
Scope of Work: construct a new prefabricated shade structure @ Washoe County Animal Shelter.
Company Name 2): Lyon County School District
Contract Person: Lyon County School District
Mailing Address: 25 East Goldfield Avenue.
City, State, Zip Code: Yerington, NV. 89447.
Complete Telephone Number: 775-463-6808
E-Mail Address:
Project Title: Silver Stage High School Concession Stand and Announcers Facility.
Amount of Contract: 278,645.76.
Scope of Work: construct a new concession stand + announcers booth @ Silver Stage High School



# BID PROPOSAL

Company Name 3):	BCN Purchasing.
Contract Person:	Teresa Golden
Mailing Address:	7000 Dardini Blvd.
City, State, Zip Code:	Reno, NV. 89512-3999
Complete Telephone Number:	775-674-4838.
E-Mail Address:	tgolden@tmcc.edu
Project Title:	Dynamometer Install.
Amount of Contract	28,638. <sup>83</sup>
Scope of Work:	install owner supplied Dynamometer at TMCC on Edison.
Company Name 4):	
Contract Person:	
Mailing Address:	
City, State, Zip Code:	
Complete Telephone Number:	
E-Mail Address:	
Project Title:	
Amount of Contract:	
Scope of Work:	

# BID PROPOSAL

## BP. 13 CERTIFICATION REGARDING DEBARMENT, SUSPENSION, AND OTHER RESPONSIBILITY MATTERS PRIMARY COVERED TRANSACTIONS

1. The prospective primary participant certifies to the best of its knowledge and belief, that it and its principals:
  - a) Are not presently debarred, suspended, proposed for debarment, declared ineligible, or voluntarily excluded by any Federal, State or Local department or agency.
  - b) Have not within a three-year period preceding this bid been convicted of or had a civil judgment rendered against them for commission of fraud or a criminal offense in connection with obtaining, attempting to obtain, or performing a public (Federal, State or Local) transaction or contract under a public transaction; violation of Federal or State antitrust statutes or commission of embezzlement, theft, forgery, bribery, falsification or destruction of records, making false statements, or receiving stolen property.
  - c) Are not presently indicted for or otherwise criminally or civilly charged by a government entity (Federal, State or Local) with commission of any of the offenses enumerated in paragraph (1)(b) of this certification; and
  - d) Have not within a three-year period preceding this bid had one or more public transactions (Federal, State or Local) terminated for cause or default.
2. Where the prospective primary participant is unable to certify to any of the statements in this certification, such prospective participant shall attach an explanation to this bid.

  
 \_\_\_\_\_  
 Signature of Authorized Certifying Official  
Rollin Smith  
 Printed Name

President  
 Title  
2-20-14  
 Date

I am unable to certify to the above statement. My explanation is attached.

\_\_\_\_\_  
Signature

\_\_\_\_\_  
Date

### BIDDER'S SAFETY INFORMATION

#### Bidder's Safety Factors:

Year	"E-Mod" Factor <sup>1</sup>	OSHA Incident Rate <sup>2</sup>
2011	.83	0
2010	.86	0

<sup>1</sup> E-Mod (Experience Modification) Factors are issued by the Employer's Insurance Company of Nevada.

<sup>2</sup> OSHA Incident Rate is the number of OSHA Recordable Accidents per 100 employees and is calculated as the number of accidents divided by 208,000.

# BID PROPOSAL

## SUBCONTRACTORS

**BP.14 INSTRUCTIONS:** for Subcontractors and General Contractors who self-perform in amounts exceeding five (5) percent of bid amount. This information must be submitted with your bid proposal. The bidder shall enter NONE under Name of Subcontractor if not utilizing subcontractors exceeding this amount and per revised NRS 338.141 (as amended by SB268), the prime contractor shall list itself on the subcontractor's list if it will be providing any of the work on the project. (This form must be complete in all respects. If, additional space is needed, attach a separate page).

Name of Subcontractor <i>Houston Smith Constr. Inc.</i>	Address <i>4010 Drake Way CO, W 89704</i>	
Phone <i>(775) 849-1802</i>	Nevada Contractor License # <i>70322</i>	Limit of License <i>\$700,000-</i>
Description of work <i>Project management, pipe structure install</i>		
Name of Subcontractor <i>Armac Construction</i>	Address	
Phone <i>(775) 884-6015</i>	Nevada Contractor License # <i>74381</i>	Limit of License <i>150,000-</i>
Description of work <i>Demo + excavation.</i>		
Name of Subcontractor <i>Valley Concrete</i>	Address <i>601 S. 15th Street.</i>	
Phone <i>(775) 329-0656</i>	Nevada Contractor License # <i>8697A + 2757B</i>	Limit of License <i>unlimited.</i>
Description of work <i>concrete bl network.</i>		
Name of Subcontractor	Address	
Phone	Nevada Contractor License #	Limit of License
Description of work		
Name of Subcontractor	Address	
Phone	Nevada Contractor License #	Limit of License
Description of work		

# BID PROPOSAL

## SUBCONTRACTORS

None

**BP.15 INSTRUCTIONS:** for Subcontractors exceeding one (1) percent of bid amount or \$50,000 whichever is greater. This information must be submitted by the three lowest bidders within two (2) hours after the completion of the opening of the bids. The bidder may elect to submit this information with the bid proposal and, in that case, the bidder will be considered as having submitted this information within the above two hours.

Name of Subcontractor	Address	
Phone	Nevada Contractor License #	Limit of License
Description of work		
Name of Subcontractor	Address	
Phone	Nevada Contractor License #	Limit of License
Description of work		
Name of Subcontractor	Address	
Phone	Nevada Contractor License #	Limit of License
Description of work		
Name of Subcontractor	Address	
Phone	Nevada Contractor License #	Limit of License
Description of work		
Name of Subcontractor	Address	
Phone	Nevada Contractor License #	Limit of License
Description of work		



# BID PROPOSAL

## SUBCONTRACTORS

Listed on  
5%

**BP. 16 INSTRUCTIONS:** for all Subcontractors not previously listed on the 5% and 1% pages. This information must be submitted by the three lowest bidders within twenty four (24) hours after the completion of the opening of the bids. The bidder may elect to submit this information with the bid proposal and, in that case, the bidder will be considered as having submitted this information within the above twenty four hours.

Name of Subcontractor	Address	
Phone	Nevada Contractor License #	Limit of License
Description of work		
Name of Subcontractor	Address	
Phone	Nevada Contractor License #	Limit of License
Description of work		
Name of Subcontractor	Address	
Phone	Nevada Contractor License #	Limit of License
Description of work		
Name of Subcontractor	Address	
Phone	Nevada Contractor License #	Limit of License
Description of work		
Name of Subcontractor	Address	
Phone	Nevada Contractor License #	Limit of License
Description of work		

# BID PROPOSAL

BP. 17

## WORKERS EMPLOYED REPORT INSTRUCTIONS FOR COMPLETION

Effective July 1, 2013, contractors who receive a preference in bidding on a public work must submit an affidavit to the public body certifying that 50 percent of all workers employed on the public work, including any employees of the contractor and of any subcontractor, will hold a valid driver's license or identification card issued by the Nevada Department of Motor Vehicles. Pursuant to NRS 338.070(4), a contractor and each subcontractor engaged on a public work shall keep an accurate record showing, for each worker employed by the contractor or subcontractor in connection with the public work who has a driver's license or identification card, the name of the worker, the driver's license number or identification card number of the worker, and the state or other jurisdiction that issued the license or card. A copy of this record must be received by the public body no later than 15 days after the end of the month. Additionally, the contractor and any subcontractor will maintain and make available for inspection within Nevada his or her records concerning payroll relating to the public work.

- EACH contractor and subcontractor must complete the Workers Employed Report.
- You may make additional copies of the report as necessary.
- A copy of this report must be submitted with the monthly certified payroll report.
- For the first report submitted, each contractor and subcontractor should list every worker employed in connection with the public work. The workers listed should be the same as those reported on the certified payroll report.
- For each subsequent month, add only those workers not previously reported to the Workers Employed Report and submit the newly-revised report. If no additional workers have been added, you may submit the previous month's report.
- If a worker has been reported on a previous month's report, but does not work during a subsequent month or is no longer employed by the contractor, his or her name should remain on the report. DO NOT DELETE ANY NAMES. This report is intended to serve as a cumulative list of all workers employed by the contractor and subcontractor over the duration of the project to verify compliance with the minimum requirements of the affidavit.

# BID PROPOSAL



## WORKERS EMPLOYED REPORT

Project Name: \_\_\_\_\_ Contract Number : \_\_\_\_\_

General Contractor: \_\_\_\_\_ PWP # \_\_\_\_\_

Subcontractor: \_\_\_\_\_ Date: \_\_\_\_\_

Address at which payroll records are maintained: \_\_\_\_\_

Contact Person and Phone Number: \_\_\_\_\_

Employee Name	Driver License Number or ID Card Number	Issuing State or Jurisdiction

# BID PROPOSAL

## Local Preference Affidavit

(This form is required to receive a preference in bidding)

I, \_\_\_\_\_, on behalf of the Contractor, \_\_\_\_\_, swear and affirm that in order to be in compliance with NRS 338.XXX\* and be eligible to receive a preference in bidding on Project No. \_\_\_\_\_, Project Name \_\_\_\_\_, certify that the following requirement will be adhered to, documented and attained on completion of the contract. Upon submission of this affidavit on behalf of \_\_\_\_\_, I recognize and accept that failure to comply with any requirements is a material breach of the contract and entitles the City to damages. In addition, the Contractor may lose their preference designation and/or lose their ability to bid on public works for one year, pursuant to NRS 338. XXX\*:

1. The Contractor shall ensure that 50 percent of the workers employed on the job possess a Nevada driver's license or identification card;
2. The Contractor shall ensure all vehicles used primarily for the public work will be registered and (where applicable) partially apportioned to Nevada;
3. The Contractor shall ensure at least 50 percent of the design professionals who work on the project (including sub-contractors) have a Nevada driver's license or identification card.
4. The Contractor shall ensure payroll records related to this project are maintained and available within the State of Nevada.

**\*Note that specific sections of NRS 338 detailing the continued procedures associated with the use of the "bidder's preference" have been amended by the passage of Assembly Bill 172 effective 7/1/13, requiring this affidavit and subsequent record keeping and reporting by the General Contractor using the preference program and awarded this project. These requirements are not applicable to Contractors who do not use the "Bidder's Preference" eligibility certificate in their bid.**

By: \_\_\_\_\_ Title: \_\_\_\_\_

Signature: \_\_\_\_\_ Date: \_\_\_\_\_

Signed and sworn to (or affirmed) before me on this \_\_\_\_\_ day of \_\_\_\_\_, 20\_\_\_\_,  
by \_\_\_\_\_ (name of person making statement).

State of \_\_\_\_\_ )  
  )ss.  
County of \_\_\_\_\_ )

\_\_\_\_\_  
Notary Signature                                      STAMP AND SEAL



In compliance with the provisions of Chapters 338 of NRS and NAC, respectively, I, as an officer, owner or director of the undersigned contractor, hereby certify that this report is a true and accurate statement of worker's earnings employed on this Public Works contract by the undersigned contractor for the following payroll period:

# BID PROPOSAL

Altered to include State of NV Regulations

Date 2-20-14  
 I, Teresa Katts Office Administrator  
 (Name of Signatory Party) (Title)

do hereby state:

(1) That I pay or supervise the payment of the persons employed by Houston Smith Construction, Inc. on the Fairgrounds Arena Project that during the payroll period commencing on the 1st day of February and ending the 1st day of March all persons employed on said project have been paid the full weekly wages earned, that no rebates have been or will be made either directly or indirectly to or on behalf of said Houston Smith Construction Inc. from the full (Contractor or Subcontractor)

weekly wages earned by any person and that no deductions have been made either directly or indirectly from the full wages earned by any person, other than permissible deductions as defined in Regulations, Part 3 (29 C.F.R. Subtitle A), issued by the Secretary of Labor under the Copeland Act, as amended (48 Stat. 948, 63 Stat. 108, 72 Stat. 967; 76 Stat. 357; 40 U.S.C. § 3145), and described below.

(2) That any payrolls otherwise under this contract required to be submitted for the above period are correct and complete; that the wage rates for laborers or mechanics contained therein are not less than the applicable wage rates contained in any wage determination incorporated into the contract; that the classifications set forth therein for each laborer or mechanic conform with the work he performed.

(3) That any apprentices employed in the above period are duly registered in a bona fide apprenticeship program registered with a State apprenticeship agency recognized by the Bureau of Apprenticeship and Training, United States Department of Labor, or if no such recognized agency exists in a State, are registered with the Bureau of Apprenticeship and Training, United States Department of Labor.

(4) That:

(a) WHERE FRINGE BENEFITS ARE PAID TO APPROVED PLANS, FUNDS, OR PROGRAMS

- in addition to the basic hourly wage rates paid to each laborer or mechanic listed in the above referenced payroll, payments of fringe benefits as listed in the contract have been or will be made to appropriate programs for the benefit of such employees, except as noted in section 4(c) below.

(b) WHERE FRINGE BENEFITS ARE PAID IN CASH

- Each laborer or mechanic listed in the above referenced payroll has been paid, as indicated on the payroll, an amount not less than the sum of the applicable basic hourly wage rate plus the amount of the required fringe benefits as listed in the contract, except as noted in section 4(c) below.

(c) EXCEPTIONS

EXCEPTION (CRAFT)	EXPLANATION

REMARKS:

NAME AND TITLE	SIGNATURE
THE WILLFUL FALSIFICATION OF ANY OF THE ABOVE STATEMENTS MAY SUBJECT THE CONTRACTOR OR SUBCONTRACTOR TO CIVIL OR CRIMINAL PROSECUTION. SEE SECTION 1001 OF TITLE 18 AND SECTION 231 OF TITLE 31 OF THE UNITED STATES CODE.	

NRS 338.070:  
 4. The contractor and each subcontractor shall keep or cause to be kept an accurate record showing the name and the actual per diem, wages and benefits paid to each workman employed by him in connection with the public work.  
 5. The record must be open at all reasonable hours to the inspection of the public body awarding the contract, and its officers and agents. The contractor or subcontractor shall ensure that a copy of the record for each calendar month is received by the public body awarding the contract no later than 15 days after the end of the month. The copy must be open to public inspection as provided in NRS 239.010. The record in the possession of the public body awarding the contract may be discarded by the public body 2 years after final payment is made by the public body for the public work.  
 6. Any contractor or subcontractor, or agent or representative thereof, performing work for a public work who neglects to comply with the provisions of this section is guilty of a misdemeanor.

# BID PROPOSAL

## BP.19 ACKNOWLEDGMENT AND EXECUTION:

STATE OF Nevada )  
  ) SS  
COUNTY OF Washoe )

I Rollin Smith (Name of party signing this Bid Proposal), do depose and say: That I am the Bidder or authorized agent of the Bidder; and that I have read and agree to abide by this Bid which includes, but is not limited to the following documents: Notice to Contractors, Table of Contents, Project Coordination, Instructions to Bidders, Bid Bond, Proposal Summary, Contract Award Instructions and Information, Sample Contract, Sample Performance Bond, Sample Labor and Material Payment Bond, General Conditions, Special Conditions, Standard Specifications, Prevailing Wage Rates, Technical Specifications, Geotechnical Report (if any), Contract Drawings, Permits (if any), and any addenda issued and understands the terms, conditions, and requirements thereof; that if his/her bid is accepted that he/she agrees to furnish and deliver all materials except those specified to be furnished by the City (Owner) and to do and perform all work for the "Fairgrounds Arena Picnic Shelter Project", contract number 1314-155, together with incidental items necessary to complete the work to be constructed in accordance with the Contract Documents, Contract Drawings, and Specifications annexed hereto.

### BIDDER:

PRINTED NAME OF BIDDER: Rollin Smith

TITLE: President

FIRM: Houston Smith Construction, Inc.

Address: 4010 Drake Way

City, State, Zip: Carson City, NV. 89704

Telephone: (775) 849-1802

Fax: (775) 546-6255

E-mail Address: rollin@houstonsmithinc.com

  
\_\_\_\_\_  
(Signature of Bidder)

DATED: 2-20-14

Signed and sworn (or affirmed) before me on this 20<sup>th</sup> day of February, 2014, by  
Rollin Smith

  
\_\_\_\_\_  
(Signature of Notary)

(Notary Stamp)

END OF BID PROPOSAL

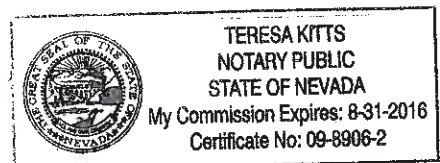

**CARSON CITY PURCHASING AND CONTRACTS**  
**201 North Carson Street, Suite 3**  
**Carson City, NV 89701**  
**775-283-7137/FAX 887-2107**  
**<http://www.carson.org/index.aspx?page=998>**

**NOTICE TO CONTRACTORS**  
**BID #1314-155**  
**Fairgrounds Arena Picnic Shelter Project**  
**PWP # CC-2014-108**

Feb. 13, 2014

Addendum No. 1

Please make the following additions/changes/clarifications to the above referenced project.

1. The time for submitting bids has been changed to 4:00 p.m. on Thursday, February 20, 2014. The **BID OPENING** will be held publicly at 4:10 p.m. on February 20, 2014

The following is based on Request For Information items received by 2/12/2014.

1. See the attached drawings showing existing grades around the project site in order to calculate cut/fill quantities.
2. Detail B-B shows 3 rails going up the ramp. There should only be a top and bottom rail shown on this detail.
3. Galvanized steel pipe may be used in place of the stainless steel handrails specified on the plans. The handrail must be continuous without any couplings at bends or points where rails intersect.
4. Please see the attached picture for an example of acceptable skate tabs for the handrails.
5. If the bid is below \$90,000 prevailing wage rates are not required.

End of Addendum #1

DESIGNED BY: DA  
 DRAWN BY: DA  
 CHECKED BY: VS, MS, SP  
 DATE: 7/20/14

CARSON CITY PUBLIC WORKS DEPARTMENT  
 1505 WEST WAY CARSON CITY, NEVADA 89701  
 FAX: 887-2355



REV.	DATE	DESCRIPTION	BY	APP'D.

FAIRGROUNDS ARENA PICNIC SHELTER  
 601 OLD CLEAR CREEK RD.  
 SITE PLAN

SHEET  
**C4.0**



SCALE  
 1" = 1'

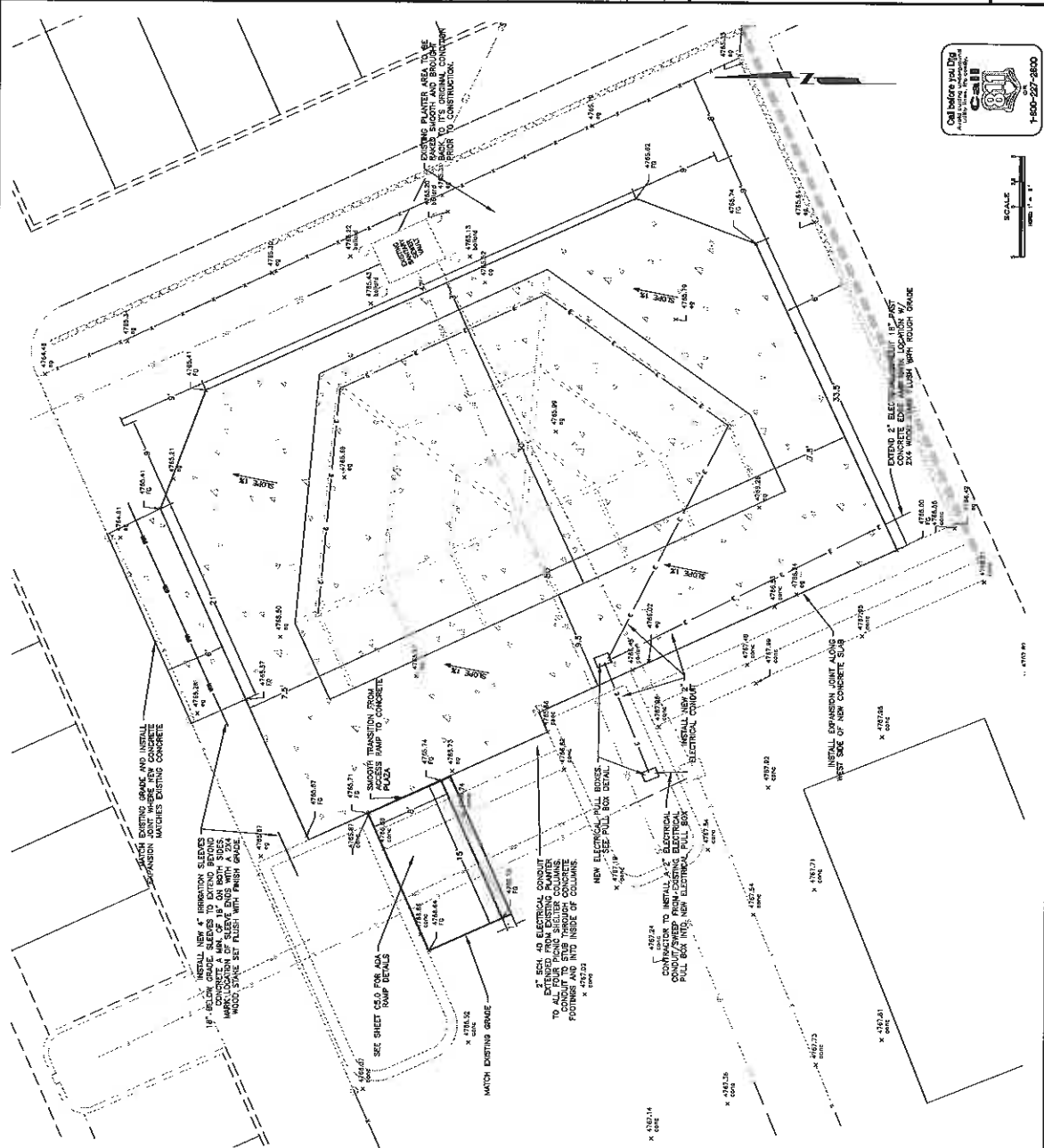

- NOTES:**
- CONTRACTOR SHALL FIELD VERIFY ALL EXISTING GRADES AND ELEVATIONS AND ADVISE THE CITY'S PROJECT MANAGER OF ANY CONFLICTS.
  - CONTRACTOR SHALL INSTALL PULL STRINGS IN ALL NEW ELECTRICAL CONDUIT WITH A MINIMUM OF 40 P.C. CONDUIT TO DUCT TAPE CLOSE ALL ENDS OF IRRIGATION SLEEVES.

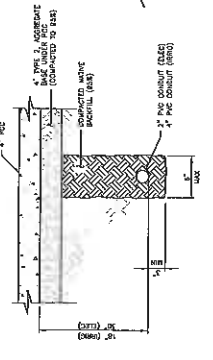

**TYPICAL CONDUIT TRENCH**  
 NOT TO SCALE

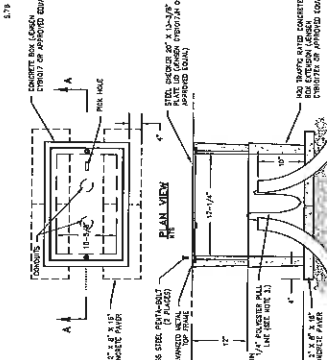

- NOTES:**
- PULL BOXES AND COVERS SHALL BE 1/2" THICK TRAPCOTE WATER.
  - CONCRETE SHALL BE SCHEDULE 80 AND CONDUIT DURING A PULLING SHALL BE TOWERED WITH A SLEEVE AND SPRING WITH AN END BELL.
  - CONTRACTOR SHALL VERIFY ALL EXISTING GRADES AND ELEVATIONS AND ADVISE THE CITY'S PROJECT MANAGER OF ANY CONFLICTS.
  - A 1/2" MINIMUM CLEARANCE SHALL BE MAINTAINED FROM THE PULLER END AND THE CONDUIT END IN THE PULL ENDS.

**ELECTRICAL PULL BOX DETAIL**  
 NOT TO SCALE





