

**City of Carson City  
Agenda Report**

**Date Submitted:** November 21, 2014

**Agenda Date Requested:** December 4, 2014

**Time Requested:** 5 minutes

**To:** Mayor and Supervisors

**From:** Purchasing and Contracts

**Subject Title:** For Possible Action: To determine that Western Nevada Supply Co., is the lowest responsive and responsible bidder pursuant to Nevada Revised Statute (NRS) Chapter 332 and to authorize Public Works to purchase Warehouse Inventory parts on an as-needed basis through November 30, 2015 with the option to renew for five (5) additional years subject to negotiation to be funded from the Various Operating Supplies Accounts in the Water, Sewer, Storm Drain, Streets and Landfill Funds as provided in the FY 2014/2015 Budget. (Contract File 1415-092) (*Kim Belt*)

**Staff Summary:** Carson City Purchasing and Contracts, on behalf of the Public Works Department, accepted sealed bids for water, sewer, storm drain, streets and landfill inventory material/parts.

**Type of Action Requested:** (check one)

Resolution                       Ordinance  
 Formal Action/Motion         Other (Specify)

**Does This Action Require A Business Impact Statement:**  Yes  No

**Recommended Board Action:** I move to determine that Western Nevada Supply Co., is the lowest responsive and responsible bidder pursuant to Nevada Revised Statute (NRS) Chapter 332 and to authorize Public Works to purchase Warehouse Inventory parts on an as-needed basis through November 30, 2015 with the option to renew for five (5) additional years subject to negotiation to be funded from the Various Operating Supplies Accounts in the Water, Sewer, Storm Drain, Streets and Landfill Funds as provided in the FY 2014/2015 Budget. (Contract File 1415-092)

**Explanation for Recommended Board Action:** *NOTICE TO BIDDERS* was published in the Nevada Appeal on October 24, 2014. The bids were opened at approximately 11:10 a.m. on November 12, 2014 at 201 North Carson Street, Carson City, Nevada 89701. Present during the bid opening were: Curtis Horton, Public Works and Kim Belt, Purchasing and Contracts.

Proposals were received from one (1) bidder. Please refer to the *BID RESPONSE* for specifics.

Staff recommends award to Western Nevada Supply Co. as the lowest responsive and responsible bidder pursuant to NRS Chapter 332.

**Applicable Statute, Code, Policy, Rule or Regulation:** N.R.S. Chapter 332 Purchasing: Local Governments.

**Fiscal Impact:** Public Works will purchase these items on an as-needed basis for their inventory.

**Explanation of Impact:** Public Works will purchase these items on an as-needed basis for their inventory.

**Funding Source:** Public Works Operating Supplies Account Budgets in the Water, Sewer, Storm Drain, Streets and Landfill Fund accounts. Currently there is \$233,110.99 budgeted in these accounts.

**Alternatives:** Do not award contract.

**Supporting Material:** Bid Response.

**Prepared By:** Kim Belt, Purchasing and Contracts Manager

Reviewed By:           D. M. Buelth - ACTING            
(Public Works)  
          Nicholas Marano            
(City Manager)  
          [Signature]            
(District Attorney)  
          [Signature]            
(Finance Director)

Date:           11/24/14            
Date:           11/24/14            
Date:           11/24/14            
Date:           11/24/14          

**Board Action Taken:**

Motion: \_\_\_\_\_ 1) \_\_\_\_\_ Aye/Nay  
2) \_\_\_\_\_  
\_\_\_\_\_  
\_\_\_\_\_  
\_\_\_\_\_  
\_\_\_\_\_

\_\_\_\_\_  
(Vote Recorded By)

10/21/14

**CARSON CITY PURCHASING AND CONTRACTS**  
**201 North Carson Street, Suite 3**  
**Carson City, NV 89701**  
**775-283-7137 / FAX 887-2107**  
**<http://www.carson.org/Index.aspx?page=998>**  
**NOTICE TO BIDDERS**  
**REQUEST FOR BID #1415-092**  
**Warehouse Inventory Parts**

October 23, 2014

**ADDENDA** are posted on Carson City's web site <http://www.carson.org/Index.aspx?page=998>. It is each Bidder's responsibility to ensure that they have received all addenda prior to submission of their sealed bid.

**SEALED BIDS** [one (1) original **BID RESPONSE** which includes all exhibits (clearly marked on the front outside cover as the original with the number and title of this **REQUEST FOR BID** as well as Bidder's name, address, e-mail address, telephone number, and fax number); three (3) copies of the **BID RESPONSE** which includes all exhibits (clearly marked on the front outside cover as a copy with the number and title of this **REQUEST FOR BID** as well as Bidder's name, address, e-mail address, telephone number, and fax number; and one (1) CD which includes the **BID RESPONSE** and all exhibits (clearly marked with the number and title of this **REQUEST FOR BID** as well as Bidder's name, address, e-mail address, telephone number, and fax number)] **must be submitted in a sealed envelope/package/box** (clearly marked with number and title of this **REQUEST FOR BID** as well as Bidder's name, address, e-mail address, telephone number, and fax number) **to CARSON CITY PURCHASING AND CONTRACTS, 201 North Carson Street, Suite 3, Carson City, Nevada 89701 by 11:00 a.m. on November 7, 2014. Bids received after the date and time set for receipt will be rejected and disqualified from consideration.**

**BID OPENING AND ACKNOWLEDGMENT** will be held publicly at 11:10 a.m. on November 7, 2014 at 201 North Carson Street, Carson City, Nevada 89701. A tabulation of the **BID RESPONSES** will be posted on Carson City's website <http://www.carson.org/Index.aspx?page=998> within 48 hours.

**AWARD RECOMMENDATION** will be made by the Carson City Purchasing and Contracts Department. You are encouraged to visit the City's website for that recommendation or contact Kim Belt at [KBelt@carson.org](mailto:KBelt@carson.org) for the recommendation.

**APPEAL BY UNSUCCESSFUL BIDDER** must be submitted in writing to Carson City Purchasing and Contracts within five (5) working days of the **BID OPENING** and must be in compliance with Nevada Revised Statute (NRS) 332.

**AWARD** will be made by the Carson City Board of Supervisors and is scheduled for Wednesday November 20, 2014, and their decision is final. The Carson City Board of Supervisors meeting will be held in the Sierra Room of the Carson City Community Center, 851 E. William Street, Carson City, NV 89701 beginning at 8:30 a.m.

## CARSON CITY PURCHASING AND CONTRACTS SPECIFICATIONS

AK  
11/11/14

### SCOPE:

Carson City Purchasing and Contracts, on behalf of the Public Works Department, is accepting sealed bids for water, sewer, storm drain, streets and landfill inventory material/parts.

Bids shall be based upon the information provided in this **REQUEST FOR BIDS**.

### GENERAL:

These SPECIFICATIONS shall be considered as the minimum standard acceptable to Carson City. Any deviations, modifications, and/or alternates proposed to the SPECIFICATIONS shall be recorded on the **EXCEPTION SUMMARY**. Failure to do so may be justification for rejection of the BID RESPONSE. Bidder must indicate the line number corresponding to the item and a detailed description of the deviation, modification, and/or alternate. Failure to note deviations, modifications, and/or alternates on the **EXCEPTION SUMMARY** shall be interpreted to convey that Bidder will perform in the manner described and/or specified in the SPECIFICATIONS.

The use of the name of a manufacturer in the SPECIFICATIONS does not restrict Bidder to that manufacturer's product specifications, unless otherwise stated in this **REQUEST FOR BID**. The reference is used to indicate the principle specifications, operating characteristics, or quality of products which have been approved by Carson City as being acceptable for its use. Bids on equivalent products or other manufacturers will be considered provided they meet the principal operating and service quality requirements of the SPECIFICATIONS stated herein including qualitative/quantitative preferences. Carson City will be the sole judge on equivalent quality/quantity and specification allowances/tolerances. Bidder may be required to submit current detailed Product-Application Specifications and related literature, product UL Listing information, and other typical test data on the product(s). This information will be used for evaluation purposes.

Only new product(s) of current design and manufacture shall be proposed and accepted under this **REQUEST FOR BID**. Bidding of demonstrator or used product(s) shall be specifically prohibited. Product(s) and/or material(s) furnished by Bidder having serious defects, corrosion, or scratches which tend to present an "other than new" appearance shall be promptly replaced or such defects promptly corrected by Bidder at no cost to Carson City. Should Carson City receive any product(s) and/or material(s) not conforming to the requirements of this **REQUEST FOR BID**, they shall be returned and replaced at Bidder's expense.

Technical specifications and literature illustrating Bidder's proposed product(s) shall be

# CARSON CITY PURCHASING AND CONTRACTS SPECIFICATIONS

*AS  
revised*

submitted and marked as "Exhibit A". Failure to do so may be justification for rejection of the **BID RESPONSE**.

All product(s) and/or materials proposed and furnished must comply with the most current O.S.H.A., N.O.S.H.A., E.P.A., Federal, State, and local laws, regulations, ordinances, and/or statutes applicable thereto. See Attachment B.

A letter from the manufacturer certifying that Bidder is an authorized representative of the manufacturer for the product(s) and/or materials being proposed and that any warranty requirements provided for herein will be performed favorably in their behalf shall be submitted and marked as "Exhibit B". Failure to do so may be justification for rejection of the **BID RESPONSE**.

## **TECHNICAL SPECIFICATIONS:**

All items will be ordered on an as-needed basis.

No guarantee is given that any specific quantities will be ordered.

All items bid shall meet the current "Carson City Standard Details for Public Works Construction" in addition to all other standard details listed.

A copy of the "Carson City Standard Details for Public Works Construction" may be obtained at the Public Works Department located at 3505 Butti Way during regular business hours.

All items shall conform to the American Water Works Association standards and all applicable ANSI, ASTM, MSS SP 60 standards.

<b>BID ITEMS</b>				
<b>Brand/s</b>	<b>Price</b>	<b>Mfg. Part #</b>	<b>CC Part #</b>	<b>Description</b>
<i>Apec/Crispin</i>	<i>150.00</i>	<i>50.2</i>	ARV-01-005	Air Release Valve 1/2"
<i>Apec/Crispin</i>	<i>150.00</i>	<i>50.2</i>	ARV-01-006	Air Release Valve 3/4"
<i>Apec/Crispin</i>	<i>150.00</i>	<i>50.2</i>	ARV-01-010	Valve-Air Rels FIP x FIP 1"
<i>Apec/Crispin</i>	<i>299.00</i>	<i>143C.1</i>	ARV-01-010A	Valve Air-Vac Rels-Combo 1"
<i>Apec/Crispin</i>	<i>400.00</i>	<i>200.2</i>	ARV-01-020	Valve-Air Rels FIP x FIP 2"
<i>Apec/Crispin</i>	<i>450.00</i>	<i>143C.1</i>	ARV-01-020A	Valve Air-Vac Rele-Combo 2"
<i>Anvil</i>	<i>19.75</i>	<i>2CF</i>	BFS-01-020	Flange-Screwed DI 2"
<i>Anvil</i>	<i>29.75</i>	<i>3CF</i>	BFS-01-030	Flange-Screwed DI 3"
<i>Anvil</i>	<i>40.00</i>	<i>4CF</i>	BFS-01-040	Flange-Screwed DI 4"
<i>Anvil</i>	<i>64.00</i>	<i>6CF</i>	BFS-01-060	Flange-Screwed DI 6"
<i>Anvil</i>	<i>79.00</i>	<i>8CF</i>	BFS-01-080	Flange-Screwed DI 8"

AS  
11/1/14

## CARSON CITY PURCHASING AND CONTRACTS SPECIFICATIONS

BID ITEMS				
Brand/s	Price	Mfg. Part #	CC Part #	Description
STAR	13.00	3BF	BFS-02-030	Flange-Blind DI 3"
STAR	18.00	4BF	BFS-02-040	Flange-Blind DI 4"
STAR	28.00	6BF	BFS-02-060	Flange-Blind DI 6"
STAR	48.00	8BF	BFS-02-080	Flange-Blind DI 8"
STAR	82.00	10BF	BFS-02-100	Flange-Blind DI 10"
STAR	129.00	12BF	BFS-02-120	Flange-Blind DI 12"
STAR	211.00	16BF	BFS-02-160	Flange-Blind DI 16"
Romac	355.00	S16-5.6	BJR-01-010	Clamp-Bell Joint Repair 12"
Romac	325.00	S16-11.40	BJR-01-012	Clamp-Bell Joint Repair 10"
Romac	295.00	S16-9.50	BJR-01-080	Clamp-Bell Joint Repair 8"
Romac	165.00	S16-5.00	BJR-01-040	Clamp-Bell Joint Repair 4"
Romac	195.00	S16-7.10	BJR-01-060	Clamp-Bell Joint Repair 6"
Nibco	8.50	600CSA	BPF-02-002	Valve-Ball FIP x FIP 1/4"
Nibco	9.00	600CSA	BPF-02-003	Valve-Ball FIP x FIP 3/8"
Nibco	10.00	600CSA	BPF-03-005	Valve-Ball FIP x FIP 1/2"
Nibco	12.00	600CSA	BPF-03-007	Valve-Ball FIP x FIP 3/4"
Nibco	18.00	600CSA	BPF-03-010	Valve-Ball FIP x FIP 1"
Red+white	8.00	267	BPF-03-011	Valve-Gate FIP X FIP 1"
Red+white	12.00	267	BPF-03-012	Valve-Gate FIP x FIP 1 1/4"
Red+white	16.00	267	BPF-03-015	Valve-Gate FIP x FIP 1 1/2"
Red+white	22.00	267	BPF-03-020	Valve-Gate FIP X FIP 2"
Red+white	6.75	70779	BPF-04-005	Valve-Check, FIP x FIP 1/2"
Red+white	8.50	70779	BPF-04-007	Valve-Check, FIP x FIP 3/4"
Red+white	11.50	70779	BPF-04-010	Valve-Check FIP X FIP 1"
Red+white	23.00	70779	BPF-04-015	Valve-Check, FIP x FIP 1 1/2"
Red+white	34.00	70779	BPF-04-020	Valve-Check, FIP x FIP 2"
Merit	2.75	BRE1445	BPF-07-001	1/4" Brass 45 FIPS x FIPS
Merit	2.25	BRE1490	BPF-07-002	Elbow-Bend FIP 1/4"
Merit	2.25	BRE3890	BPF-07-003	Elbow-Bend FIP 3/8"
Merit	3.50	BRE1290	BPF-07-005	Elbow-Bend FIP 1/2"
Merit	5.00	BRE3490	BPF-07-007	Elbow-Bend FIP 3/4"
Merit	7.75	BRE1490	BPF-07-010	Elbow-Bend FIP 1"
Merit	12.50	BRE11490	BPF-07-012	Elbow-Bend FIP 1 1/4"
Merit	19.50	BRE11290	BPF-07-015	Elbow-Bend FIP 1 1/2"

# CARSON CITY PURCHASING AND CONTRACTS SPECIFICATIONS

*As indicated*

BID ITEMS				
Brand/s	Price	Mfg. Part #	CC Part #	Description
Merit	25.50	BRF290	BPF-07-020	Elbow-Bend FIP 2"
Merit	3.00	BRF14T	BPF-08-002	Tee-FIP 1/4"
Merit	3.00	BRF38T	BPF-08-003	Tee-FIP 3/8"
Merit	4.50	BRF12T	BPF-08-005	Tee-FIP 1/2"
Merit	6.50	BRF34T	BPF-08-007	Tee-FIP 3/4"
Merit	11.50	BRF1T	BPF-08-010	Tee-FIP 1"
Merit	16.00	BRF114T	BPF-08-012	Tee-FIP 1 1/4"
Merit	22.00	BRF112T	BPF-08-015	Tee-FIP 1 1/2"
Merit	35.50	BRF2T	BPF-08-020	Tee-FIP 2"
Merit	2.00	BRF14P	BPF-09-002	Plug-MIP 1/4"
Merit	2.00	BRF38P	BPF-09-003	Plug-MIP 3/8"
Merit	2.50	BRF12P	BPF-09-005	Plug-MIP 1/2"
Merit	3.00	BRF34P	BPF-09-007	Plug-MIP 3/4"
Merit	3.75	BRF1P	BPF-09-010	Plug-MIP 1"
Merit	5.50	BRF114P	BPF-09-012	Plug-MIP 1 1/4"
Merit	7.50	BRF112P	BPF-09-015	Plug-MIP 1 1/2"
Merit	11.00	BRF2P	BPF-09-020	Plug-MIP 2"
Merit	2.00	BRF14CAP	BPF-10-002	Cap-FIP 1/4"
Merit	2.00	BRF38CAP	BPF-10-003	Cap-FIP 3/8"
Merit	2.50	BRF12CAP	BPF-10-005	Cap-FIP 1/2"
Merit	3.00	BRF34CAP	BPF-10-007	Cap-FIP 3/4"
Merit	5.00	BRF1CAP	BPF-10-010	Cap-FIP 1"
Merit	7.25	BRF114CAP	BPF-10-012	Cap-FIP 1 1/4"
Merit	9.50	BRF112CAP	BPF-10-015	Cap-FIP 1 1/2"
Merit	16.00	BRF2CAP	BPF-10-020	Cap-FIP 2"
Beckett	7.50	34 mvc	BPF-10-908F	3/4" Double Vent Cap
Beckett	10.00	1 mvc	BPF-10-908G	1" Double Vent Cap
Merit	2.50	BRF14C	BPF-11-002	Coupling-FIP 1/4"
Merit	2.50	BRF38C	BPF-11-003	Coupling-FIP 3/8"
Merit	3.00	BRF12C	BPF-11-005	Coupling-FIP 1/2"
Merit	4.00	BRF34C	BPF-11-007	Coupling-FIP 3/4"
Merit	6.25	BRF1C	BPF-11-010	Coupling-FIP 1"
Merit	9.50	BRF114C	BPF-11-012	Coupling-FIP 1 1/4"
Merit	12.50	BRF112C	BPF-11-015	Coupling-FIP 1 1/2"
Merit	21.00	BRF2C	BPF-11-020	Coupling-FIP 2"

75  
11/16/14

## CARSON CITY PURCHASING AND CONTRACTS SPECIFICATIONS

BID ITEMS				
Brand/s	Price	Mfg. Part #	CC Part #	Description
merit	2.50	BRF1438R	BPF-12-052	Reducer-Bell, FIP 1/4x3/8"
merit	3.00	BRF312R	BPF-12-073	Reducer-Bell, FIP 3/8x1/2"
merit	4.50	BRF312LR	BPF-12-101	Reducer-Bell, FIP 1/2x3/4"
merit	7.00	BRF134R	BPF-12-102	Reducer-Bell, FIP 3/4x1"
merit	14.50	BRF1121R	BPF-12-211	Reducer-Bell, FIP 1x1 1/2"
merit	25.00	BRF234R	BPF-12-248	Reducer-Bell, FIP 3/4 x 2"
merit	25.00	BRF21R	BPF-12-249	Reducer-Bell, FIP 1 x 2"
merit	.89	BRN141	BPF-16-021	Nipple-MIP 1/4 x 1"
merit	1.16	BRN142	BPF-16-022	Nipple-MIP 1/4 x 2"
merit	.92	BRN381	BPF-16-031	Nipple-MIP 3/8 x 1"
merit	2.25	BRN384	BPF-16-034	Nipple-MIP 3/8 x 4"
merit	1.23	BRN1214	BPF-16-051	Nipple-MIP 1/2 x 1 1/4"
Merit	2.33	BRN123	BPF-16-053	Nipple-MIP 1/2 x 3"
merit	1.77	BR34C	BPF-16-071	Nipple-MIP 3/4 x 1/2"
merit	5.68	BRN346	BPF-16-076	Nipple-MIP 3/4 x 6"
merit	2.61	BRN1C	BPF-16-101	Nipple-MIP 1 x CLS
merit	3.22	BRN12	BPF-16-102	Nipple-MIP 1 x 2"
merit	4.33	BRN13	BPF-16-103	Nipple-MIP 1 x 3"
merit	6.02	BRN1143	BPF-16-123	Nipple-MIP 1 1/4 x 3"
merit	7.59	BRN1123	BPF-16-153	Nipple-MIP 1 1/2 x 3"
Merit	14.60	BRN1126	BPF-16-156	Nipple-MIP 1 1/2 x 6"
merit	9.72	BRN23	BPF-16-203	Nipple-MIP 2 x 3"
merit	18.77	BRN26	BPF-16-206	Nipple-MIP 2"x6"
Pasco	3.44	2142	BPF-22-011	Adaptor-FM Hose x Hose 3/4"
Pasco	4.75	2142	BPF-22-012	Adaptor-FM Hose x FM Hose SWV 3/4"
Pasco	3.71	2144	BPF-22-013	Adaptor 1/2" X 3/4 " F hose SWV
merit	1.95	BRF3814B	BPF-22-020	Bushing-FIPxMIP 1/4x3/8"
merit	1.95	BRF1214B	BPF-22-022	Bushing-FIPxMIP 1/4x1/2"
merit	1.95	BRF1238B	BPF-22-030	Bushing-FIPxMIP 3/8x1/2"
merit	2.50	BRF342B	BPF-22-050	Bushing-FIPxMIP 1/2x3/4"
merit	3.75	BRG112B	BPF-22-051	Bushing-FIPxMIP 1/2x1"
merit	3.00	BRF3414B	BPF-22-052	Bushing Brass 3/4 X 1/4"
merit	3.95	BRF134B	BPF-22-071	Bushing-FIPxMIP 3/4x1"
merit	10.00	BRF11234B	BPF-22-075	Bushing-FIPxMIP 3/4x1 1/2"
merit	14.75	BRF234B	BPF-22-078	Bushing-FIPxMIP 3/4x2"
merit	8.25	BRF1121B	BPF-22-101	Bushing-FIPxMIP 1x1 1/2"
merit	14.75	BRF21B	BPF-22-102	Bushing-FIPxMIP 1x2"



## CARSON CITY PURCHASING AND CONTRACTS SPECIFICATIONS

AS  
11/10/14

BID ITEMS				
Brand/s	Price	Mfg. Part #	CC Part #	Description
Merit	12.50	BSF 2112 B	BPF-22-152	Bushing-FIPxMIP 1 1/2x2
Ford/mueller	49.00	B25028	BSF-02-007	Stop-Corp, F x MIP 3/4"
Ford/mueller	N/A	---	BSF-02-008	Stop-Corp, F x MIP 3/4x1"
Ford/mueller	64.00	B25028	BSF-02-010	Stop-Corp, F x MIP 1"
Ford/mueller	145.00	B25028	BSF-02-015	Stop-Corp, Comp x MIP 1 1/2"
Ford/mueller	240.00	B25028	BSF-02-020	Stop-Corp, F x MIP 2"
Ford/mueller	88.00	AV91-323W	BSF-05-007	Stop-Mtr F x YOKE Angle 3/4"
Ford/mueller	91.00	AV91-444W	BSF-05-010	Stop-Mtr F x YOKE Angle 1"
Ford/mueller	85.00	B91-323W	BSF-06-007	Stop-Mtr F x YOKE 3/4"
Ford/mueller	89.00	B91-344W	BSF-06-010	Stop-Mtr F x YOKE 1"
Ford/mueller	52.00	T444-444	BSF-07-134	Tee-Service FxFxF 1x1x1"
Ford/mueller	70.00	H15343	BSF-07-136	Brass Compression Y 1" X 3/4" X 3/4"
Ford/mueller	85.00	H15343	BSF-07-137	Brass Compression Y 1-1/2" x 1" x 1"
Ford/mueller	29.00	H581	BSF-08-007M	Check Valve MIPxFIP STR 3/4"
Ford/mueller	37.00	H591	BSF-08-010S	Check Valve FIPxMTR STR 1"
Ford/mueller	18.00	H15403	BSF-09-007	Coupling-3P FxF 3/4"
Ford/mueller	21.00	H15403	BSF-09-010	Coupling-3P FxF 1"
Ford/mueller	69.00	H15403	BSF-09-015	Coupling-3P FxF 1 1/2"
Ford/mueller	94.00	H15403	BSF-09-020	Coupling-3P FxF 2"
Ford/mueller	14.50	H15428	BSF-11-007	Adaptor-Coupling CTS Comp x MIP 3/4"
Ford/mueller	17.50	H15428	BSF-11-010	Adaptor-Coupling CTS Comp x MIP 1"
Ford/mueller	48.50	H15428	BSF-11-015	Adaptor-Coupling CTS Comp x MIP 1 1/2"
Ford/mueller	70.00	H15428	BSF-11-020	Adaptor-Coupling CTS Comp x MIP 2"
Ford/mueller	16.00	H15451	BSF-12-007	Adaptor-Coupling CTS Comp x FIP 3/4"
Ford/mueller	22.75	H15451	BSF-12-010	Adaptor-Coupling CTS Comp x FIP 1"
Ford/mueller	62.00	H15451	BSF-12-015	Adaptor-Coupling CTS Comp x FIP 1 1/2"
Ford/mueller	74.00	H15451	BSF-12-020	Adaptor-Coupling CTS Comp x FIP 2"
Ford/mueller	15.50	H15533	BSF-13-007	Elbow-Service 90 CTS Comp X MIP 3/4"
Ford/mueller	76.50	H15533	BSF-13-010	Elbow-Service 90 CTS Comp x MIP 1"
Ford/mueller	80.00	H15533	BSF-13-015	Elbow-Service 90 CTS Comp x MIP 1 1/2"
Ford/mueller	114.00	H15533	BSF-13-020	Elbow-Service 90 CTS Comp x MIP 2"

AS  
1/16/14

## CARSON CITY PURCHASING AND CONTRACTS SPECIFICATIONS

BID ITEMS				
Brand/s	Price	Mfg. Part #	CC Part #	Description
Ford Mueller	20.00	H15533	BSF-14-007	Elbow- Service 90 CTS Comp x FIP 3/4"
Ford Mueller	34.50	H15533	BSF-14-010	Elbow- Service 90 CTS Comp x FIP 1"
Ford Mueller	88.00	H15533	BSF-14-015	Elbow- Service 90 CTS Comp x FIP 1 1/2"
Ford Mueller	101.00	H15533	BSF-14-020	Elbow- Service 90 CTS Comp x FIP 2"
Ford Mueller	3.99	YLN4	BSF-15-010	Nut-Yoke Lock 1"
Ford Mueller	11.00	A-23	BSF-17-100	Adaptor-Meter 5/8"x3/4" to 3/4"
Ford Mueller	27.00	A-24	BSF-17-110	Adaptor-Meter 5/8"x3/4" to 1"
Ford Mueller	169.00	A-47	BSF-17-112	Adaptors 1 1/2" MTR in Pairs
Ford Mueller	225.00	A-67	BSF-17-115	Adaptor-1 1/2" x 2" MTR in Pairs
Ford Mueller	185.00	A-46	BSF-17-118	Adaptor-1" x 2" MTR in Pairs
Ford Mueller	9.85	C91-23	BSF-20-007	Outlet-Yoke Piece 3/4"
Ford Mueller	16.50	C91-44	BSF-20-010	Outlet-Yoke Piece 1"
Ford Mueller	21.50	EC-23	BSF-22-007	Expander for Meter 5/8" x3/4"
Ford Mueller	32.50	EC-4	BSF-22-010	Expander for Meter X1"
Ford Mueller	29.00	112mf	BSF-23-015	Flange-Comp WTR MTR 1 1/2"
Ford Mueller	39.00	2mf	BSF-23-020	Flange-Comp WTR MTR 2"
Ford Mueller	81.00	C17-66	BSF-25-015	Adaptor-FIPxPVC compression 1/12"
Ford Mueller	109.00	C17-77	BSF-25-020	Adaptor-FIPxPVC compression 2"
Ford Mueller	.84	PF12FA	BSF-26-015	Adaptor-FIPT x PVC 1 1/2"
Ford Mueller	1.13	PF2FA	BSF-26-020	Adaptor-FIPT x PVC 2"
Allied	7.79	2RF50	BWF-08-020	Flange-S/O Steel Weld 2"
Allied	10.58	3RF50	BWF-08-030	Flange-S/O Steel Weld FIT 3"
Allied	13.26	4RF50	BWF-08-040	Flange-S/O Steel Weld FIT 4"
Allied	21.79	6RF50	BWF-08-060	Flange-S/O Steel Weld FIT 6"
Allied	33.09	8RF50	BWF-08-080	Flange-S/O Steel Weld FIT 8"
Allied	57.11	10RF50	BWF-08-100	Flange-S/O Steel Weld FIT 10"
Allied	84.69	12RF50	BWF-08-120	Flange-S/O Steel Weld FIT 12"
Allied	175.92	16RF50	BWF-08-160	Flange-S/O Steel Weld FIT 16"
Allied	11.68	H3CF	BWF-09-422	Flange-S/O Steel Weld FIT 3"x4"
Griswold	1899.00	90-016	CAL-01-020A	CaL-VAL PRV #90-01 IPxIP 2" 90G-01APSKC 300# stainless steel trim and tubes
Griswold	1800.00	90-016	CAL-01-020	CaL-VAL PRV #90-01 FXF 2" 90G-01APSKC 150# stainless steel trim and tubes
Griswold	2350.00	90-016	CAL-01-040	CaL-VAL PRV #90-01 FXF 4" 90G-01BPYKC 150# stainless steel trim and tubes
Griswold	3695.00	90-016	CAL-01-060	CaL-VAL PRV #90-01 FXF 6" 90G-01BPYKC 150# stainless steel trim and tubes
Griswold	5580.00	90-016	CAL-01-080	CaL-VAL PRV #90-01 FXF 8" 90G-01BPYKC 150# stainless steel trim and tubes
Romac	1540.00	RC400	CCI-01-124	Coupling 28.35 x 25.80 24" X 30"

11/11/14

## CARSON CITY PURCHASING AND CONTRACTS SPECIFICATIONS

BID ITEMS				
Brand/s	Price	Mfg. Part #	CC Part #	Description
Ronac	60. <sup>00</sup>	SOICR	CCI-02-120	Adaptor-CPLG 501 Ductile Iron AB Barrel 10"
Ronac	72. <sup>00</sup>	SOICR	CCI-02-121	Adaptor-CPLG 501 Ductile Iron AB Barrel 12"
Ronac	60. <sup>00</sup>	SOICR	CCI-03-010	Coupling -STR Comp Barrel 10"
Ronac	69. <sup>00</sup>	SOIER	CCI-03-016B	Coupling End Ring 501 Black 16"
Ronac	69. <sup>00</sup>	SOIER	CCI-03-016R	Coupling End Ring 501 Red 16"
Ronac	69. <sup>00</sup>	SOIER	CCI-03-016Y	Coupling End Ring 501 Yellow 16"
Ronac	31. <sup>00</sup>	SOICR	CCI-03-040	Coupling-STR COMP Barrel 4"
Ronac	11. <sup>00</sup>	SOIER	CCI-03-041	Coupling-STR COM End Ring 4"
Ronac	5. <sup>00</sup>	SOIG	CCI-03-045	Coupling gasket 4"
Ronac	35. <sup>00</sup>	SOICR	CCI-03-060	Coupling-STR COMP Barrel 6"
Ronac	19. <sup>00</sup>	SOIER	CCI-03-061	Coupling-STR COMP End-Ring 6"
Ronac	8. <sup>00</sup>	SOIG	CCI-03-066	CPLG-STR COMP Gasket 6"
Ronac	44. <sup>00</sup>	SOICR	CCI-03-080	Coupling Barrel 8"
Ronac	26. <sup>00</sup>	SOIER	CCI-03-081	Coupling-8" Ductile Iron End-Ring
Ronac	11. <sup>00</sup>	SOIG	CCI-03-085	Coupling Gasket 501 8"
Ronac	28. <sup>00</sup>	SOIER	CCI-03-101B	Coupling End Ring 501 Black 10"
Ronac	28. <sup>00</sup>	SOIER	CCI-03-101R	Coupling End Ring 501 Red 10"
Ronac	28. <sup>00</sup>	SOIER	CCI-03-101Y	Coupling End Ring 501 Yellow 10"
Ronac	21. <sup>00</sup>	SOIG	CCI-03-105	Coupling Gasket 501 10"
Ronac	36. <sup>00</sup>	SOIG	CCI-03-160	Coupling Gasket 501 16"
Ronac	225. <sup>00</sup>	SOICR	CCI-03-166	Coupling Comp Barrel 501 16"
Ronac	540. <sup>00</sup>	SOIFCA	CCI-06-010	Coupling Adapt 501 FCA 10"
Ronac	595. <sup>00</sup>	SOIFCA	CCI-06-012	Coupling Adapt FCA 12"
Ronac	<del>820.<sup>00</sup></del> 820. <sup>00</sup>	SOIG	CCI-06-016	Coupling Gasket FCA 16"
Ronac	1339. <sup>00</sup>	RFC400	CCI-06-018	Coupling ADPT FCA 16" OD 18.0
Ronac	1540. <sup>00</sup>	RC400	CCI-06-024	24" Transition coupling 25.80 X 28.52
Ronac	170. <sup>00</sup>	SOIFCA	CCI-06-040	Coupling Adpt 501 FCA 4"
Ronac	240. <sup>00</sup>	SOIFCA	CCI-06-060	Coupling Adpt FCA 6"
Ronac	298. <sup>00</sup>	SOIFCA	CCI-06-080	Coupling Adpt FCA 501 8"
Mueller/AVK	455. <sup>00</sup>	A-2360	CIF-01-040	Valve-M J Gate 4"
Mueller/AVK	580. <sup>00</sup>	A-2360	CIF-01-060	Valve-M J Gate 6"
Mueller/AVK	399. <sup>00</sup>	A-2360	CIF-10-030	Valve-Flanged Gate 3"
Mueller/AVK	445. <sup>00</sup>	A-2360	CIF-10-040	Valve-Flanged Gate 4"
Mueller/AVK	599. <sup>00</sup>	A-2360	CIF-10-060	Valve-Flanged Gate 6"
Mueller/AVK	925. <sup>00</sup>	A-2360	CIF-10-080	Valve-Flanged Gate 8"
Mueller/AVK	1450. <sup>00</sup>	A-2360	CIF-10-100	Valve-Flanged Gate 10"
Mueller/AVK	1775. <sup>00</sup>	A-2360	CIF-10-120	Valve-Flanged Gate 12"

## CARSON CITY PURCHASING AND CONTRACTS SPECIFICATIONS

AS  
11/11/14

BID ITEMS				
Brand/s	Price	Mfg. Part #	CC Part #	Description
Mudler/Pentt	2575.00	165B	CIF-10-160	Butterfly Valve FLG X FLG 16"
STAR	150.00	4FT	CIF-11-040	Tee-Flanged 4"
STAR	190.00	6FT	CIF-11-060	Tee-Flanged 6"
STAR	315.00	8FT	CIF-11-080	Tee-Flanged 8"
STAR	225.00	86FT	CIF-11-086	Tee-Flange 8"x6"
STAR	485.00	10FT	CIF-11-100	Tee-Flanged 10"
STAR	80.00	4F90	CIF-12-040	Elbow- Flanged 90° 4"
STAR	125.00	6F90	CIF-12-060	Elbow- Flanged 90° 6"
STAR	205.00	8F90	CIF-12-080	Elbow- Flanged 90° 8"
STAR	75.00	6mj90	CIF-14-060	6" MJ x MJ 90°
STAR	60.00	6mj45	CIF-14-061	6" MJ x MJ 45°
mateco	255.00	3ULfm	CIF-15-030	Valve - Flanged Check 3"
mateco	355.00	4ULfm	CIF-15-040	Valve - Flanged Check 4"
mateco	755.00	6ULfm	CIF-15-060	Valve - Flanged Check 6"
mateco	1265.00	8ULfm	CIF-15-080	Valve - Flanged Check 8"
mateco	1795.00	10ULfm	CIF-15-100	Valve - Flanged Check 10"
mateco	2325.00	12ULfm	CIF-15-120	Valve - Flanged Check 12"
Mudler/Pentt	1995.00	165B	CIF-16-140	Valve - Flanged Butterfly 14"
Mudler/AVK	463.55	A-2360	CIF-21-040	Valve - Push On 4"
Mudler/AVK	455.00	A-2360	CIF-21-041	Valve - Push X Flange 4"
STAR	75.00	4P090	CIF-22-040	Elbow- Push On 90° 4"
STAR	125.00	6P090	CIF-22-060	Elbow- Push On 90° 6"
STAR	180.00	8P090	CIF-22-080	Elbow- Push On 90° 8"
STAR	250.00	10P090	CIF-22-100	Elbow- Push On 90° 10"
STAR	415.00	12P090	CIF-22-120	Elbow- Push On 90° 12"
STAR	65.00	4P0FA	CIF-23-141A	Push On x Flange Adpt 4"
STAR	105.00	6P0FA	CIF-23-142	Push On x Flange Adpt 6"
STAR	140.00	8P0FA	CIF-23-143	Push On x Flange Adpt 8"
STAR	58.00	43FR	CIF-24-040	Flange x Flange Di Adpt 3"x4"
STAR	89.00	64FR	CIF-24-060	Flange x Flange Di Adpt 4"x6"
STAR	145.00	86FR	CIF-24-080	Flange x Flange Di Adpt 6"x8"
STAR	34.00	4P0CAP	CIF-25-040	Cap-Push On 4"

## CARSON CITY PURCHASING AND CONTRACTS SPECIFICATIONS

AS  
11/11/14

BID ITEMS				
Brand/s	Price	Mfg. Part #	CC Part #	Description
STAR	53.00	6PCAP	CIF-25-060	Cap-Push On 6"
STAR	81.00	8PCAP	CIF-25-080	Cap-Push On 8"
STAR	164.00	10PCAP	CIF-25-100	Cap-Push On 10"
STAR	150.00	12PCAP	CIF-25-120	Cap-Push On 12"
STAR	105.00	6PO45	CIF-28-060	Elbow- PO 45° 6"
STAR	155.00	8PO45	CIF-28-080	Elbow-Push On 45° 8"
Muller/AVK	455.00	A 2360	CIF-32-040	Valve-Gate Push On x Flange 4"
Muller/AVK	599.00	A 2360	CIF-32-060	Valve-Gate Push On x Flange 6"
Muller/AVK	945.00	A 2360	CIF-32-080	Valve-Gate Push On X Flange 8"
Muller/AVK	1779.00	A 2360	CIF-32-120	Valve-Gate Push On X Flange 12"
STAR	365.00	126PCT	CIF-32-121	12" Push On X 12" Push On X 6" Flange Tee
STAR	215.00	86PCT	CIF-33-086	8" Push On x 8" Push On X 6" Flange Tee
Romac	265.00	CL2T	FCR-01-435	Clamp-DBL Lug 3/4" Tap 4x16"
Romac	300.00	CL2T	FCR-01-537	Clamp-Single Lug Tap IP 6 X 12 X 2"
Romac	300.00	CL2T	FCR-01-538	Clamp- Double Lug Tap IP 6 "X 12" X 1"
Romac	300.00	CL2T	FCR-01-539	Clamp-DBL Lug Tap 6x16"
Romac	249.00	CL1	FCR-02-031	Clamp 12"x16" Single Lug
Romac	480.00	CL1	FCR-02-043	Clamp 12"X 30" Single Lug
Romac	135.00	CL2	FCR-02-429	Clamp-Double LUG 4x10"
Romac	144.00	CL2	FCR-02-539	Clamp-Double LUG 6x10"
Romac	156.00	CL2	FCR-02-589	Clamp-Double LUG 8x10"
Romac	171.00	CL2	FCR-02-590	Clamp-Double LUG 8" X 12"
Romac	215.00	CL2	FCR-02-595	Clamp-Double LUG 8x16"
Romac	249.00	CL2	FCR-02-629	Clamp-Double LUG 10"X 12"
Romac	216.00	CL2	FCR-02-639	Clamp-Double LUG 12x10"
Romac	395.00	CL2	FCR-02-655	Clamp-Double LUG 12x20"
Romac	595.00	CL2	FCR-02-658	Clamp-Double LUG 12x30"
Romac	496.00	CL2	FCR-02-664	Clamp-Double LUG 14x16"
Romac	595.00	CL2	FCR-02-665	Double Lug Clamp 12" x 30" long
Romac	345.00	CL2	FCR-02-665A	Double Lug Clamp 12" x 18" long
Romac	599.00	CL1	FCR-02-666	Single Lug Clamp 14" x 20" long
Romac	289.00	CL2	FCR-02-687	Clamp-Double LUG 16"x 8" long
Romac	504.00	CL2	FCR-02-695	Clamp-Double LUG 16"x 16"long
Romac	1085.00	CL1	FCR-02-696	Single Lug Clamp 18" x 30" long
Romac	1295.00	CL2	FCR-02-760	Clamp-Double LUG 24" x 20" long
Romac	129.00	CL1	FCR-03-539	Clamp Single Lug 6" X 12" long

## CARSON CITY PURCHASING AND CONTRACTS SPECIFICATIONS

AS  
11/11/14

BID ITEMS				
Brand/s	Price	Mfg. Part #	CC Part #	Description
Romac	199.00	CL1	FCR-03-540	Clamp Single Lug 6" X 16" long
ford/muller	18.65	Y202	FMY-01-010	Yoke-Meter Epoxy Coated 5/8" x 3/4" Y202 wintergreen
ford/muller	22.65	Y504	FMY-01-072	Yoke-Meter Epoxy Coated 1" Y504
Hillman	69.00	212160	GAG-01-000	Gauge Pressure 0-160 2 1/2" Dial Face
pasco		3414H	GAG-01-001	3/4 FM Hose x Swivel 1/4 FMPT
Ashcraft	69.00	212200	GAG-01-002	Gauge-Pressure 0-200 2 1/2" Dial Face
Ashcraft	69.00	212300	GAG-01-003	Gauge-Pressure 0-300 2 1/2" Dial Face
Ashcraft	75.00	4200	GAG-01-004	Gauge - Pressure 0-200 4" Dial Face
Ashcraft	205.00	4390SND	GAG-01-005	Gauge-Well SNDG 0-390 4 1/2" Dial Face
Ashcraft	85.00	412200	GAG-01-006	Gauge Pressure 0-200 4 1/2" Dial Face
Ashcraft	75.00	145	GAG-01-020	Snubber-Pressure 1/4"
Romac	43.00	46Di	GRP-DI-004	4" Grip Ring Restraint
Romac	49.00	66Di	GRP-DI-006	6" Grip Ring Restraint
Romac	70.00	86Di	GRP-DI-008	8" Grip Ring Restraint
Romac	101.00	106Di	GRP-DI-010	10" Grip Ring Restraint
Romac	138.00	126Di	GRP-DI-012	12" Grip Ring Restraint
us pipe	7.50	2FT6	GSK-02-020	Gasket-Ring Fullface Rubber 2"
us pipe	11.00	3FT6	GSK-02-030	Gasket-Ring Fullface Rubber 3"
us pipe	10.00	4FT6	GSK-02-040	Gasket-Ring Fullface Rubber 4"
us pipe	13.00	6FT6	GSK-02-060	Gasket-Ring Fullface Rubber 6"
us pipe	17.50	8FT6	GSK-02-080	Gasket-Ring Fullface Rubber 8"
us pipe	20.00	10FT6	GSK-02-100	Gasket-Ring Fullface Rubber 10"
us pipe	22.50	12FT6	GSK-02-120	Gasket-Ring Fullface Rubber 12"
us pipe	55.00	24FT6	GSK-02-124	Gasket-Ring Fullface Rubber 24"
us pipe	37.00	14FT6	GSK-02-140	Gasket-Ring Fullface Rubber 14"
us pipe	45.00	16FT6	GSK-02-160	Gasket-Ring Fullface Rubber 16"
STAR	2.00	4TJWR	GSK-04-040	Gasket-Tyton DI/CI Rubber 4"
STAR	3.00	6TJWR	GSK-04-060	Gasket-Tyton DI/CI Rubber 6"
STAR	4.00	8TJWR	GSK-04-080	Gasket-Tyton DI/CI Rubber 8"
STAR	5.00	10TJWR	GSK-04-100	Gasket-Tyton DI/CI Rubber 10"
STAR	6.00	12TJWR	GSK-04-120	Gasket-Tyton DI/CI Rubber 12"
STAR	8.00	16TJWR	GSK-04-160	Gasket-Tyton DI/CI Rubber 16"
STAR	2.00	4mJTB	GSK-05-040	Gasket-AC/CI Rubber Trans 4"

# CARSON CITY PURCHASING AND CONTRACTS SPECIFICATIONS

AS  
11/11/14

BID ITEMS				
Brand/s	Price	Mfg. Part #	CC Part #	Description
STAR	2.00	4mJTG	GSK-05-040A	Gasket-AC/IPS Rubber Trans 4"
STAR	3.00	6mJTG	GSK-05-060	Gasket-AC/CI Rubber Trans 6"
STAR	3.00	6mJTG	GSK-05-060A	Gasket-ACxIPS Rubber Tran 6"
STAR	4.00	8mJTG	GSK-05-080	Gasket-AC/CI Rubber Trans 8"
STAR	4.00	8mJTG	GSK-05-080A	Gasket-AC/IPS Rubber Trans 8"
Lemac	45.00	4flg	GSK-06-040	Gasket-Tyler Grip Tite Rubber
Lemac	65.00	6flg	GSK-06-060	Gasket-Tyler Grip Tite Rubber
Lemac	85.00	8flg	GSK-06-080	Gasket-Tyler Grip Tite Rubber
Lemac	125.00	10flg	GSK-06-100	Gasket-Tyler Grip Tite Rubber
Lemac	145.00	12flg	GSK-06-120	Gasket-Tyler Grip Tite Rubber
HRP	105.00	BRK	HYD-01-065	Hydrant-WTRS Brake Flg Rpr
HRP	105.00	TRK	HYD-01-069	Hydrant-WTRS Trfc Rpr Kit
HRP	271.00	6wex	HYD-01-075	Hydrant-WTRS Stpipe Ext 6"
HRP	317.00	12wex	HYD-01-076	Hydrant-WTRS Stpipe Ext 12"
HRP	421.00	18wex	HYD-01-077	Hydrant-WTRS Ext Kit 18"
HRP	245.00	6mex	HYD-06-006	Hyd Muler Ext Kit A301006 6"
HRP	285.00	12mex	HYD-06-012	Hyd Muler Ext Kit A301010 12"
HRP	330.00	18mex	HYD-06-018	Hyd Muler Ext Kit A320-016 18"
HRP	125.00	A301	HYD-06-035	Hyd Muler Sfty Flg Kit A301
HRP	145.00	A307	HYD-06-036	Hydrant Muler SFTY FLG KIT A307
HRP	125.00	A11	HYD-A-011	Stem Mueller 1987 & later 27 1/2"
HRP	105.00	A58	HYD-A-058	Stem Mueller MOD Cent Muel
Smith Blair	175.00	226-1210	LRC-01-121	Clamp-Band-Aid Redi Standard 12" x 10" long
Smith Blair	170.00	226-126	LRC-01-123	Clamp-Redi Standard 12" x 6" long
Smith Blair	5.00	226-123	LRC-01-333	Clamp-Redi Standard 1/2" IP x 3" long
Smith Blair	5.00	226-343	LRC-01-334	Clamp-Redi Standard 3/4 IP x 3" long
Smith Blair	5.00	226-13	LRC-01-335	Clamp-Redi Standard 1" IP x 3" long
Smith Blair	7.00	226-1143	LRC-01-336	Clamp-Redi Standard 1 1/4" IP x 3" long
Smith Blair	7.00	226-1123	LRC-01-337	Clamp-Redi Standard 1 1/2" IP x 3" long
Smith Blair	7.00	226-23	LRC-01-338	Clamp-Redi Standard 2" IP x 3" long
Smith Blair	8.00	226-126	LRC-01-522	Clamp-Redi Standard 1/2" x 6" long
Smith Blair	8.00	226-346	LRC-01-523	Clamp-Redi Standard 3/4" IP x 6" long
Smith Blair	8.00	226-16	LRC-01-524	Clamp-Redi Standard 1" IP x 6" long
Smith Blair	9.00	226-1146	LRC-01-525	Clamp-Redi Standard 1 1/4" IP x 6" long
Smith Blair	9.00	226-1126	LRC-01-526	Clamp-Redi Standard 1 1/2" IP x 6" long
Smith Blair	9.00	226-26	LRC-01-528	Clamp-Redi Standard 2" IP x 6" long

## CARSON CITY PURCHASING AND CONTRACTS SPECIFICATIONS

AS  
11/11/14

BID ITEMS				
Brand/s	Price	Mfg. Part #	CC Part #	Description
Smith Blair	25. <sup>00</sup>	245-36	LRC-01-530	Clamp-Redl Standard 3" steel x 6" long
Smith Blair	30. <sup>00</sup>	245-46	LRC-01-532	Clamp-Redl Standard 4" steel x 6" long
Smith Blair	35. <sup>00</sup>	245-66	LRC-01-535	Clamp-Redl Standard 6" steel x 6" long
Smith Blair	40. <sup>00</sup>	245-86	LRC-02-585	Clamp-Redl Standard 8" steel x 6" long
Old Castle	73. <sup>00</sup>	B1017B	MBX-01-090AA	B1017 Box H/2O loading 10" X 17"
Old Castle	29. <sup>50</sup>	B1017X	MBX-01-090BB	B1017 X12 H/2O loading Extension 10" x17"
Old Castle	105. <sup>00</sup>	B1017 61JH	MBX-01-090CC	B1017 -61JH Steel cover H/2O loading 10" x 17"
Old Castle	31. <sup>00</sup>	B24 B	MBX-01-091A	B24 Concrete Box 20 3/4 x 19 1/4
Old Castle	138. <sup>00</sup>	B24-61D	MBX-01-091C	B24-61D steel checker plate cover
Old Castle	190. <sup>00</sup>	B1730-B	MBX-01-092A	B-1730 H/2O loading Box 17 x 30
Old Castle	82. <sup>00</sup>	B1730x	MBX-01-092B	B-1730 X12 H/2O loading extension 17 x 30
Old Castle	250. <sup>00</sup>	B1730 51JH	MBX-01-092C	B-1730 -51JH H/2O loading steel checker plate cover 17 x 30
Old Castle	172. <sup>00</sup>	B52B	MBX-01-093A	Christy Concrete B-52 Box 30x60
Old Castle	172. <sup>00</sup>	B52B	MBX-01-093B	B-52 Utility Box 30" x 60"
Old Castle	325. <sup>00</sup>	B52D	MBX-01-093C	B-52 D 2 piece reinforced concrete lid
Carson	31. <sup>00</sup>	1419B	MBX-01-094A	Bottom-Plastic ONLY 5/8 x 1"
Carson	23. <sup>00</sup>	1419x	MBX-01-094B	Extension-Plastic 5/8 x 1"
Carson	12. <sup>00</sup>	1419L	MBX-01-094C	Lid-Plastic 5/8 x 1"
Old Castle	105. <sup>00</sup>	B40B	MBX-01-095A	B-40 Meter Box
Old Castle	76. <sup>00</sup>	B40x	MBX-01-095B	B-40 10" Ext
Old Castle	93. <sup>50</sup>	B40L	MBX-01-095C	B-40 Lid 1 pc
Old Castle	91. <sup>00</sup>	F136B	MBX-02-251A	FL-36 Fibrelyte Box 17 x 30
Old Castle	60. <sup>00</sup>	F136x	MBX-02-251B	FL-36 Fibrelyte Extension 8"
Old Castle	88. <sup>50</sup>	F136L	MBX-02-251C	FL-36 Fibrelyte Lid 17 x 30
Old Castle	33. <sup>00</sup>	G3B	MBX-03-638B	Christy G3 Traffic Valve Box
Old Castle	NA	---	MBX-03-639B	Box-Brooks Valve Lid 10x12"
Old Castle	26. <sup>50</sup>	G5B	MBX-04-639A	Christy G5 traffic valve Box
Old Castle	19. <sup>00</sup>	G5L	MBX-04-639B	Christy G5C cast iron Lid for traffic valve box
Old Castle	25. <sup>00</sup>	G5GR10	MBX-04-640A	Christy G5GR10 Grade Ring 1"
Old Castle	34. <sup>00</sup>	G5GR15	MBX-04-640B	Christy G5GR15 Grade Ring 1 1/2"
Old Castle	37. <sup>00</sup>	G5GR20	MBX-04-640C	Christy G5GR20 Grade Ring 2"
Conit Mueller	825. <sup>00</sup>	106H-1422	MBX-06-218	Copper setter with by-pass 2" x 18"
Conit Mueller	635. <sup>00</sup>	98H-1422	MBX-07-153	Copper setter with by-pass 1 1/2" x 12"
HRP	6. <sup>00</sup>	A12	MUE-01-A12	Mueller A12 Stem O Ring
HRP	10. <sup>00</sup>	A15	MUE-01-A15	Mueller A15 Pump Nozzel Gasket
HRP	3. <sup>50</sup>	A19	MUE-01-A19	Mueller A19 Hose Nozzle Gasket
HRP	120. <sup>00</sup>	A45	MUE-01-A45	Mueller Main Valve brass 5-1/4
HRP	12. <sup>00</sup>	A51	MUE-01-A51	Mueller A15 10.5 OZ OIL



# CARSON CITY PURCHASING AND CONTRACTS SPECIFICATIONS

AS  
2/11/14

BID ITEMS				
Brand/s	Price	Mfg. Part #	CC Part #	Description
HRP	50.00	A84	MUE-A-003	Mueller Hold Down Inter nut
HRP	6.00	A3	MUE-A-005	Mueller Hold Down Outer O Ring
HRP	4.00	6208	MUE-A-006	Mueller Anti-Fric Wash
HRP	3.00	A7	MUE-A-007	Mueller Oil Fill Plug
HRP	13.00	H59	MUE-A-010	Mueller Bonnet Gasket
HRP	5.00	A30	MUE-A-039	Mueller Top Seat O Ring
HRP	6.50	A44	MUE-A-044	Mueller Bottom Seat O Ring
HRP	5.00	A85	MUE-A-085	Mueller Weather Seal
Wilkins	42.00	12YBxLC	PIF-01-005	Strainer-Y 1/2"
Wilkins	49.00	34YBxLC	PIF-01-007	Strainer-Y 3/4"
Centennial	.22	34CTSR	PIP-01-007	PE-Plastic Pipe CTS 3/4" cost per/ft
Centennial	.36	1CTSR	PIP-01-010	PE-Plastic Pipe CTS 1" cost per/ft
Centennial	.75	112CTSR	PIP-01-015	PE-Plastic Pipe CTS 1 1/2" cost per/ft
Centennial	1.25	2CTSR	PIP-01-020	PE-Plastic Pipe CTS 2" cost per/ft
Cresline	3.60	PP1240	PIP-04-005	PVC-Schedule 40 1/2" x 20' long
Cresline	5.00	PP3440	PIP-04-007	PVC-Schedule 40 3/4" x 20' long
Cresline	7.00	PP140	PIP-04-010	PVC-Schedule 40 1" x 20' long
Cresline	11.00	PP11240	PIP-04-015	PVC-Schedule 40 1 1/2" x 20' long
Cresline	15.00	PP240	PIP-04-020	PVC-Schedule 40 2" x 20' long
DPC/VT	45.00	4DR18	PIP-07-040	PVC-C-900 Class 235 4" x 20' long
DPC/VT	85.00	6DR18	PIP-07-060	PVC-C-900 Class 235 6" X 20' long
DPC/VT	139.50	8DR18	PIP-07-080	PVC-C-900 Class 235 8" x 20' long
DPC/VT	215.00	10DR18	PIP-07-100	PVC-C-900 Class 235 10" x 20' long
DPC/VT	319.50	12DR18	PIP-07-120	PVC-C-900 Class 235 12" x 20' long
DPC/VT	720.00	16DR18	PIP-07-160	PVC-C-905 Class 235 16" x 20' long
DPC/VT	185.00	8DR14	PIP-08-080	PVC-C-900 Class (305) 8" x 20' long
DPC/VT	350.00	12DR14	PIP-08-120	PVC-C-900 Class (305) 12" x 20' long
us pipe	290.00	6DIP	PIP-09-060	Ductile-Iron Class 350 6" x 20' long
us pipe	350.00	8DIP	PIP-09-080	Ductile-Iron Class 350 8" x 20' long
us pipe	450.00	10DIP	PIP-09-100	Ductile-Iron Class 350 10" x 20" long
us pipe	570.00	12DIP	PIP-09-120	Ductile-Iron Class 350 12" x 20" long
us pipe	1700.00	24DIP	PIP-09-124	Ductile-Iron Class 350 24" x 20" long
us pipe	1180.00	16DIP	PIP-09-160	Ductile-Iron Class 350 16" x 20" long
Legend	4.00	12BIC	PPF-01-005	Coupling-Insert INS x INS 1/2"
Legend	5.00	34BIC	PPF-01-007	Coupling-Insert INS x INS 3/4"
Legend	6.00	1BIC	PPF-01-010	Coupling-Insert INS x INS 1"
Legend	10.00	112BIC	PPF-01-015	Coupling-Insert INS x INS 1 1/2"
Legend	12.00	2BIC	PPF-01-020	Coupling-Insert INS x INS 2"

# CARSON CITY PURCHASING AND CONTRACTS SPECIFICATIONS

AS  
11/11/14

BID ITEMS				
Brand/s	Price	Mfg. Part #	CC Part #	Description
Legend	3.00	12Bim	PPF-02-005	Adptr MIP x INSERT 1/2"
Legend	4.00	34Bim	PPF-02-007	Adptr MIP x INSERT 3/4"
Legend	5.00	1Bim	PPF-02-010	Adptr MIP x INSERT 1"
Legend	8.00	112Bim	PPF-02-015	Adptr MIP x INSERT 1 1/2"
Legend	12.00	2Bim	PPF-02-020	Adptr MIP x INSERT 2"
Spears	.27	PF1290	PV4-01-005	Elbow- 90 SxS 1/2"
Spears	.31	PF3490	PV4-01-007	Elbow- 90 SxS 3/4"
Spears	.56	PF190	PV4-01-010	Elbow- 90 SxS 1"
Spears	.98	PF11490	PV4-01-012	Elbow- 90 SxS 1 1/4"
Spears	1.05	PF11290	PV4-01-015	Elbow- 90 SxS 1 1/2"
Spears	1.64	PF290	PV4-01-020	Elbow- 90 SxS 2"
Spears	.18	PF12C	PV4-02-005	Coupling-SxS 1/2"
Spears	.25	PF34C	PV4-02-007	Coupling-SxS 3/4"
Spears	.43	PF1C	PV4-02-010	Coupling-SxS 1"
Spears	.60	PF114C	PV4-02-012	Coupling-SxS 1 1/4"
Spears	.64	PF112C	PV4-02-015	Coupling-SxS 1 1/2"
Spears	.98	PF2C	PV4-02-020	Coupling-SxS 2"
Spears	.34	PF12T	PV4-03-005	Tee-SxSxS 1/2"
Spears	.39	PF34T	PV4-03-007	Tee-SxSxS 3/4"
Spears	.73	PF1T	PV4-03-010	Tee-SxSxS 1"
Spears	1.15	PF114T	PV4-03-012	Tee-SxSxS 1 1/4"
Spears	1.39	PF112T	PV4-03-015	Tee-SxSxS 1 1/2"
Spears	2.02	PF2T	PV4-03-020	Tee-SxSxS 2"
Spears	.25	PF12MA	PV4-04-005	Adaptor-Male S x MIP 1/2"
Spears	.27	PF34MA	PV4-04-007	Adaptor-Male S x MIP 3/4"
Spears	.49	PF1MA	PV4-04-010	Adaptor-Male S x MIP 1"
Spears	.80	PF112MA	PV4-04-015	Adaptor-Male S x MIP 1 1/2"
Spears	1.05	PF2MA	PV4-04-020	Adaptor-Male S x MIP 2"
Spears	.31	PF12FA	PV4-05-005	Adaptor-Female S x FIP 1/2"
Spears	.37	PF34FA	PV4-05-007	Adaptor-Female S x FIP 3/4"
Spears	.45	PF1FA	PV4-05-010	Adaptor-Female S x FIP 1"
Spears	.71	PF114FA	PV4-05-012	Adaptor-Female S x FIP 1 1/4"
Spears	.80	PF112FA	PV4-05-015	Adaptor-Female S x FIP 1 1/2"
Spears	1.07	PF2FA	PV4-05-020	Adaptor-Female S x FIP 2"
Spears	.25	PF12CAP	PV4-06-005	Cap-Slip 1/2"
Spears	.28	PF34CAP	PV4-06-007	Cap-Slip 3/4"
Spears	.45	PF1CAP	PV4-06-010	Cap-Slip 1"
Spears	.64	PF114CAP	PV4-06-012	Cap-Slip 1 1/4"
Spears	.71	PF112CAP	PV4-06-015	Cap-Slip 1 1/2"

## CARSON CITY PURCHASING AND CONTRACTS SPECIFICATIONS

11/11/14

BID ITEMS				
Brand/s	Price	Mfg. Part #	CC Part #	Description
Spears	.84	PF2CAP	PV4-06-020	Cap-Slip 2"
Spears	.28	PF3412B	PV4-07-101	Bush SxS 1/2" x 3/4"
Spears	.52	PF134B	PV4-07-131	Bush SxS 3/4" x 1"
Spears	.71	PF1141B	PV4-07-168	Bush SxS 1" x 1 1/4"
Spears	.74	PF1121B	PV4-07-211	Bush SxS 1 1/2" x 1"
Spears	1.23	PF21B	PV4-07-249	Bush SxS 2" x 1"
Spears	1.23	PF212B	PV4-07-251	Bush SxS 1 1/2" x 2"
Spears	.40	PF124S	PV4-08-005	ELL-45 SxS 1/2"
Spears	.50	PF344S	PV4-08-007	ELL-45 SxS 3/4"
NDS	2.35	34pvccc	PV4-09-007	PVC Compression Coupling 3/4"
NDS	3.06	1pvccc	PV4-09-010	PVC Compression Coupling 1"
NDS	4.69	114pvccc	PV4-09-012	PVC Compression Coupling 1 1/4"
NDS	4.84	112pvccc	PV4-09-015	PVC Compression Coupling 1 1/2"
NDS	6.50	2pvccc	PV4-09-020	PVC Compression Coupling 2"
NDS	12.50	212pvccc	PV4-09-025	PVC Compression Coupling 2 1/2"
NDS	25.00	4pvccc	PV4-09-040	PVC Compression Coupling 4"
NDS	2.15	34SF	PV4-10-007	IPS SLIP FIX 3/4"
NDS	2.53	1SF	PV4-10-010	IPS SLIP FIX 1"
NDS	5.12	112SF	PV4-10-015	IPS SLIP FIX 1 1/2"
NDS	7.94	2SF	PV4-10-020	IPS SLIP FIX 2"
Asahi	29.75	TU 1601	PV4-09-007A	PVC Ball Check Valve FIP x FIP 3/4"
Ronac	39.00	202NS	S/S-10-043A	Service Saddle-Epxy coated ductile iron 4.50 - 5.40 4"x 1" tap
Ronac	48.00	202NS	S/S-10-048A	Service Saddle-Epxy coated ductile iron 4.50 - 5.40 4"x 2" tap
Ronac	45.00	101N	S/S-10-066	Service Saddle-Epxy coated ductile iron 6.63 - 7.50 6"x 1" tap
Ronac	52.00	101N	S/S-10-068A	Service Saddle-Epxy coated ductile iron 6.63 - 7.50 6"x 2" tap
Ronac	54.00	101N	S/S-10-084	Service Saddle-Epxy coated ductile iron 8.63 - 9.62 8"x 1" tap
Ronac	63.00	101N	S/S-10-088A	Service Saddle-Epxy coated ductile iron 8.63 - 9.62 8"x 2" tap
Ronac	59.00	101N	S/S-10-103A	Service Saddle-Epxy coated ductile iron 11.10 - 12.12 10"x 1" tap
Ronac	70.00	101N	S/S-10-108A	Service Saddle-Epxy coated ductile iron 11.10 - 12.12 10"x 2" tap
Ronac	75.00	101N	S/S-10-123	Service Saddle-Epxy coated ductile iron 13.20 - 14.38 12"x 1" tap
Ronac	83.00	101N	S/S-10-128	Service Saddle-Epxy coated ductile iron 13.20 - 14.38 12"x 2" tap

## CARSON CITY PURCHASING AND CONTRACTS SPECIFICATIONS

~~11/11/14~~

BID ITEMS				
Brand/s	Price	Mfg. Part #	CC Part #	Description
Romac	170. <sup>00</sup>	101N	S/S-10-163	Service Saddle-Epxy coated ductile iron 17.40 - 18.90 16"x 1" tap
Romac	180. <sup>00</sup>	101N	S/S-10-168	Service Saddle-Epxy coated ductile iron 17.40 - 18.90 16"x 2" tap
Romac	399. <sup>00</sup>	SST	S/S-20-064A	Stainless Steel Tapping Sleeve with ductile iron flange 6.89-7.30 6"x 4"
Romac	530. <sup>00</sup>	SST	S/S-20-066B	Stainless Steel Tapping Sleeve with ductile iron flange 7.10-7.30 6"x 6"
Romac	530. <sup>00</sup>	SST	S/S-20-066C	Stainless Steel Tapping Sleeve with ductile iron flange 6.90-7.10 6"x 6"
Romac	710. <sup>00</sup>	SST	S/S-20-085	Stainless Steel Tapping Sleeve with ductile iron flange 8.62-9.06 8" x 4"
Romac	420. <sup>00</sup>	SST	S/S-20-086	Stainless Steel Tapping Sleeve with ductile iron flange 8.62-9.06 8" x 6"
Romac	420. <sup>00</sup>	SST	S/S-20-086A	Stainless Steel Tapping Sleeve with ductile iron flange 9.04-9.45 8" x 6"
Romac	675. <sup>00</sup>	SST	S/S-20-088	Stainless Steel Tapping Sleeve with ductile iron flange 8.62-9.06 8" x 8"
Romac	675. <sup>00</sup>	SST	S/S-20-088A	Stainless Steel Tapping Sleeve with ductile iron flange 9.04-9.45 8" x 8"
Romac	575. <sup>00</sup>	SST	S/S-20-106	Stainless Steel Tapping Sleeve with ductile iron flange 10.73-11.13 10" x 6"
Romac	575. <sup>00</sup>	SST	S/S-20-106A	Stainless Steel Tapping Sleeve with ductile iron flange 11.79-12.19 10" x 6"
Romac	695. <sup>00</sup>	SST	S/S-20-108	Stainless Steel Tapping Sleeve with ductile iron flange 10.73-11.13 10" x 8"
Romac	695. <sup>00</sup>	SST	S/S-20-108A	Stainless Steel Tapping Sleeve with ductile iron flange 11.79-12.19 10" x 8"
Romac	1250. <sup>00</sup>	SST	S/S-20-108C	Stainless Steel Tapping Sleeve with ductile iron flange 12.90-13.30 10" x 10"
Romac	575. <sup>00</sup>	SST	S/S-20-126B	Stainless Steel Tapping Sleeve with ductile iron flange 13.98-14.38 12" x 6"
Romac	699. <sup>00</sup>	SST	S/S-20-128	Stainless Steel Tapping Sleeve with ductile iron flange 12.50-12.90 12" x 8"
Romac	699. <sup>00</sup>	SST	S/S-20-128B	Stainless Steel Tapping Sleeve with ductile iron flange 13.98-14.38 12" x 8"
Romac	1325. <sup>00</sup>	SST	S/S-20-128C	Stainless Steel Tapping Sleeve with ductile iron flange 13.98-14.38 12" x 12"
Romac	1138. <sup>00</sup>	SST	S/S-20-166	Stainless Steel Tapping Sleeve with ductile iron flange 17.40-17.80 16" x 6"
Romac	1320. <sup>00</sup>	SST	S/S-20-168	Stainless Steel Tapping Sleeve with ductile iron flange 17.15-17.55 16" X 8"
Romac	825. <sup>00</sup>	SS3	S/S-20-128D	Stainless Steel Repair Clamp 13.65-14.65 12" X 18"
Romac	1195. <sup>00</sup>	SS3	S/S-20-128E	Stainless Steel Repair Clamp 13.65-14.65 12" x 30"

# CARSON CITY PURCHASING AND CONTRACTS SPECIFICATIONS

## **CONTRACT TERM:**

This Contract shall not become effective until and unless approved by the Carson City Board of Supervisors.

The term of this Contract will be from November 20, 2014 through November 19, 2015.

Carson City shall reserve the right to renew this Contract for five (5) years, subject to negotiation.

Bidder shall guarantee the pricing through November 19, 2015.

## **ESCALATION AND DE-ESCALATION:**

Product(s) supplied pursuant to the provisions of this **REQUEST FOR BID** shall be subject to escalation and/or de-escalation of prices as indicated herein; (i.e., conditions brought about due to market fluctuation may result in such changes). Escalation and/or de-escalation shall be as set forth by the following provisions:

### **Base Price:**

For purposes of this **REQUEST FOR BID** and bid / contract award, the base price shall be established by Bidder's **BID RESPONSE**. This price, once the **BID RESPONSE** is opened and bid / contract award made, shall not be changed except as provided by the conditions stipulated herein.

### **De-escalation:**

Adjustments decreasing the "Base Price" shall be concurrent with Bidder's price from his supplier(s). Should Bidder have legal access to more than one supplier, he shall be aggressive in his endeavor to obtain the lowest responsive and responsible supplier capable of providing products that meet or exceed the requirements of this **REQUEST FOR BID**. Bidder shall promptly notify Carson City Purchasing and Contracts by telephonic facsimile and e-mail of the adjusted price, product involved, and the date of effect.

### **Escalation:**

Adjustments increasing the "Base Price" may be concurrent with Bidder's price from his supplier(s), provided Bidder can substantiate the necessity for such an adjustment, and that it is consistent with market conditions. Should Bidder have legal access to more than one supplier, he shall be aggressive in his endeavor to obtain the lowest responsive and responsible supplier capable of providing products that meet or exceed the requirements of this **REQUEST FOR BID**. Bidder shall promptly notify Carson City Purchasing and Contracts by telephonic facsimile and e-mail of the adjusted price, product involved, and

## **CARSON CITY PURCHASING AND CONTRACTS SPECIFICATIONS**

the date of effect. Notification shall be prior to the distribution of, or commitment to distribute, any product(s) affected by such an adjustment.

In the event, price adjustments are inconsistent with market conditions, and in the opinion of Carson City Purchasing and Contracts, the best interest of the Carson City, would be served by a re-bid to the competitive market, Carson City reserves the right to waive the notification requirements of this agreement and terminate the bid / contract award without regard to the thirty (30) day written notice. The method necessary for such notice of termination shall be at the discretion of Carson City Purchasing and Contracts.

### **WARRANTIES AND GUARANTIES:**

Bidder agrees that any warranty or guarantee provided Carson City shall not be considered as the exclusive remedy of Carson City for any default in any respect by Bidder, but such warranty or guarantee shall be considered to be in addition to any right or remedy allowed by this **REQUEST FOR BID**, law, equity, or statute.

Bidder warrants that all deliverables and work product under this **REQUEST FOR BID** shall be completed in a workmanlike manner consistent with standards in the trade, profession, or industry; shall conform to or exceed the **SPECIFICATIONS**; and shall be fit for ordinary use, of good quality, with no material defects. A copy of Bidder's warranty indicating the terms, conditions, and limitations shall be submitted and marked as 'EXHIBIT C'. Warranty shall be specific as to whether or not this warranty is of a standard nature, or if it is being modified to meet or satisfy the requirements of this **REQUEST FOR BID**. Failure to do so may be justification for rejection of the **BID RESPONSE**.

Bidder guarantees that he will have full legal right of all processes, programs, methods, and techniques employed under the performance of this **REQUEST FOR BID**, and agrees to pay all rents, fees, and royalties of every description on any and all patents or patent rights, or copyrights, covering said processes, programs, methods, or techniques. Bidder guarantees to observe and comply with all federal, state, local, and municipal laws, ordinances, rules, and regulations in any way affecting this **REQUEST FOR BID**. Bidder guarantees to comply with all provisions of federal, state, and local regulations to ensure that no employee or applicant for employment is discriminated against because of race, religion, color, sex, sexual preference, marital status, age, handicap, or national origin. Bidder guarantees to be in compliance with Immigration and Naturalization Laws regarding eligibility of their employees or subcontractors to work in the United States. Bidder guarantees that any and all prices which he may charge under the terms of this **REQUEST FOR BID**, do not and will not, violate any existing federal, state, or municipal laws or regulations concerning price discrimination and/or price fixing. Bidder agrees to indemnify, exonerate, and hold Carson City harmless from liability for any such violation

## CARSON CITY PURCHASING AND CONTRACTS SPECIFICATIONS

now and throughout the term of the bid / contract award.

### **DELIVERY SCHEDULE:**

Bidder shall provide delivery F.O.B. Carson City Public Works, 3505 Butti Way, Carson City, Nevada C/O Tom Gordon, Warehouse Supply Coordinator.

Bidder shall delivery to Carson City not less than twice each working day Monday through Friday.

Delivery shall be within one (1) working day from date order is placed.

All prices shall be F.O.B. Carson City. No additional charges for freight, packaging, handling, insurance, etc., shall be allowed. Bidder shall be responsible for all shipping charges for items returned due to error and/or unacceptable condition.

At time of delivery, Bidder shall provide a delivery invoice. Within 48 hours of delivery, Bidder shall fax an invoice to Public Works at 775-887-2164 which Carson City will use for the purpose of paying Bidder. Bidder shall not mail a duplicate invoice unless specifically requested by Carson City.

### **DEFAULT OF CONTRACT:**

Should Bidder fail to deliver the product(s) and/or perform the service(s) bid in accordance with this **REQUEST FOR BID**, Carson City may declare Bidder in default of contract and recover all damages, costs and fees (including Attorney's fees) allowable by law.

In the event of default by Bidder, Carson City may, at its option, pursue one or all of the following alternatives including: procure the product(s) and/or service(s) from another source and hold the defaulting Bidder responsible for an excess cost occasioned thereby, assess a penalty of 5% of the total awarded bid amount, commence with Surety and/or Performance Bond proceedings, debar the defaulting Bidder for not less than one year, or pursue other applicable legal remedies.

If necessity requires the use of materials or supplies not conforming to the **SPECIFICATIONS**, they may be accepted and payment shall be made at a proper adjustment in price.

### **DEFAULT OF CONTRACT:**

Should Bidder fail to deliver the product(s) and/or perform the service(s) bid in accordance with this **REQUEST FOR BID**, Carson City may declare Bidder in default of contract and

## **CARSON CITY PURCHASING AND CONTRACTS SPECIFICATIONS**

recover all damages, costs and fees (including Attorney's fees) allowable by law.

In the event of default by Bidder, Carson City may, at its option, pursue one or all of the following alternatives including: procure the product(s) and/or service(s) from another source and hold the defaulting Bidder responsible for an excess cost occasioned thereby, assess a penalty of 5% of the total awarded bid amount, commence with Surety and/or Performance Bond proceedings, debar the defaulting Bidder for not less than one year, or pursue other applicable legal remedies.

If necessity requires the use of materials or supplies not conforming to the **SPECIFICATIONS**, they may be accepted and payment shall be made at a proper adjustment in price.

**\* \* \* END OF SPECIFICATIONS \* \* \***



## **CARSON CITY PURCHASING AND CONTRACTS TERMS AND CONDITIONS**

These **TERMS & CONDITIONS** shall be considered as the minimum standard acceptable to Carson City. Any deviations, modifications, and/or alternates proposed to the **TERMS & CONDITIONS** shall be recorded on the **EXCEPTION SUMMARY**. Failure to do so may be justification for rejection of the **BID RESPONSE**. Bidder must indicate the line number corresponding to the item and a detailed description of the deviation, modification, and/or alternate. Failure to note deviations, modifications, and/or alternates on the **EXCEPTION SUMMARY** shall be interpreted to convey that Bidder will perform in the manner described and/or specified in the **TERMS & CONDITIONS**.

### **NOTICE OF RIGHTS:**

Carson City reserves the right to accept or reject any or all bids or portions thereof, received by reason of this **REQUEST FOR BID**.

Carson City shall not be liable for any costs incurred by Bidders prior to the bid / contract award by the Carson City Board of Supervisors.

Carson City reserves the right to waive any irregularities and/or informalities in the submitted **BID RESPONSE**. Should Carson City elect to waive a right it will not constitute an automatic waiver of that right in the future nor will it impact any other right or remedy.

Carson City reserves the right to accept or reject any or all deviations, modifications and/or alternates offered, based solely on the value of said deviations, modifications and/or alternates to Carson City.

Carson City reserves the right to require such surety as may be deemed necessary for the protection of Carson City or to ensure the satisfactory performance of Bidder in accordance with this **REQUEST FOR BID**.

Carson City reserves the right to withhold bid / contract award for a period of sixty (60) calendar days from the date set for **BID OPENING AND ACKNOWLEDGMENT** which is indicated on page one of this **REQUEST FOR BID**.

Carson City reserves the right to award in whole or in part, by item, group of items, or by section where such action would serve Carson City's best interest. However, Bidder may record in the **EXCEPTION SUMMARY** that his **BID RESPONSE** must be awarded by Carson City on the basis of "**ALL OR NOTHING**".

Carson City reserves the right to issue a Contract or Purchase Order document without further discussion or negotiations with Bidder provided the bid / contract award is made within sixty (60) calendar days from the date set for **BID OPENING AND ACKNOWLEDGMENT** which is indicated on page one of this **REQUEST FOR BID**.

## **CARSON CITY PURCHASING AND CONTRACTS TERMS AND CONDITIONS**

Carson City reserves the right to require Bidder to provide an on-site demonstration at no cost to Carson City.

### **SALES/USE TAX EXEMPT STATUS:**

Pursuant to Nevada Revised Statute 372.325 and related statutes, CARSON CITY CONSOLIDATED MUNICIPALITY has been granted sales/use tax exempt status. Direct purchase of tangible personal property made by CARSON CITY CONSOLIDATED MUNICIPALITY is exempt from sales/use tax.

### **JOINDER OR MUTUAL USE OF CONTRACT:**

Pursuant to Nevada Revised Statute 332.195 (1), local governments and the State of Nevada may join or use the contracts of local governments located within or outside this State with the authorization of the contracting vendor. Carson City is not liable for the obligations of the governmental entity which joins or uses this Contract. Carson City shall be held harmless in any and all transactions between the successful bidder and other participating governmental entities.

### **QUESTIONS:**

All questions must be directed, in writing via e-mail, to Kim Belt, Purchasing and Contracts Manager, [kbelt@carson.org](mailto:kbelt@carson.org) at least four (4) working days prior to the date set for **BID OPENING AND ACKNOWLEDGMENT** which is indicated on page one of this **REQUEST FOR BID**.

You must indicate that these questions pertain to **REQUEST FOR BID #1415-092**. You must indicate what line number(s) your question(s) references. You must provide a contact person, their title, their e-mail address, their telephone number, and their fax number.

Questions and answers will be posted on Carson City's website <http://www.carson.org/Index.aspx?page=998> at least two (2) working days prior to the date set for **BID OPENING AND ACKNOWLEDGMENT** which is indicated on page one of this **REQUEST FOR BID**.

Any communication with other Carson City personnel regarding this **REQUEST FOR BID** may result in the rejection of your firm's **BID RESPONSE**.

# CARSON CITY PURCHASING AND CONTRACTS TERMS AND CONDITIONS

## **REQUEST FOR BID ERRORS:**

Bidders shall notify Kim Belt, Purchasing and Contracts Manager, in writing via e-mail, of any perceived conflicts, errors, or discrepancies in this **REQUEST FOR BID** as soon as possible so that corrective addenda may be furnished to all Bidders. Any addenda issued prior to the date and time set for the receipt of **SEALED BIDS** which is indicated on page one of this **REQUEST FOR BID** shall be made part of this **REQUEST FOR BID**. All addenda must be signed, placed in date and time order, submitted, and marked as "EXHIBIT D". Failure to do so may be justification for rejection of the **BID RESPONSE**.

All addenda are posted on Carson City's website <http://www.carson.org/Index.aspx?page=998>. It is each Bidder's responsibility to ensure that they have received all addenda prior to submission of their sealed bid.

## **TELEPHONE:**

Bidder shall maintain telephone service such that Carson City may contact or leave a message for Bidder at any time. Bidder shall provide advance notice to Carson City Purchasing and Contracts of any change in telephone number.

## **BID RESPONSE, CONTRACT, AND DISPOSITION:**

The contents of the **BID RESPONSE** including all **EXHIBITS** submitted by Bidder and accepted by Carson City shall become part of the contractual obligation and incorporated by reference into any ensuing Contract. All bids shall become the property of Carson City and shall not be returned to Bidder. Any information submitted in the **BID RESPONSE** that Bidder desires to be held proprietary shall be labeled as such. Carson City Purchasing and Contracts shall make the final determination regarding which information, if any, shall be held proprietary pursuant to Nevada Revised Statutes 332.025 and 332.061.

## **PREPARATION OF BID RESPONSE:**

Bid must be prepared on the **BID RESPONSE** form supplied by Carson City Purchasing and Contracts in accordance with this **REQUEST FOR BID**. All expenses incurred as a result of **BID RESPONSE** preparation shall be the responsibility of Bidder and shall not be chargeable to Carson City.

In the upper right hand corner of the **BID RESPONSE** including all exhibits, Bidder shall initial and date each page. Failure to do so may be justification for rejection of the **BID RESPONSE**.

## **CARSON CITY PURCHASING AND CONTRACTS TERMS AND CONDITIONS**

Bidder shall respond to each item listed on the **BID RESPONSE**. If additional space is required to respond to an item, Bidder shall indicate on company letterhead the item number as well as the additional information to be provided and mark as "**Exhibit E**". Supplemental materials may be provided and shall be marked as "**Exhibit F**". All the blank spaces shall be completed.

Bidders are expected to examine all documents of this **REQUEST FOR BID**. Failure to do so will be at Bidder's risk.

Bidders are urged to proofread their **BID RESPONSE** carefully for any errors. Failure to do so will be at Bidder's risk.

Numbers shall be stated in both figures and in writing. In the event of a difference between written words and figures, the amount stated in written words shall govern and the amount will be corrected accordingly. In the case of a difference between a unit price and the extended price, the unit price shall govern and the amount will be corrected accordingly.

Erasures and other changes must be initialed in blue ink by the person signing this **BID RESPONSE**.

The original **BID RESPONSE** shall contain all original signatures where required. Signatures shall be signed in longhand by an individual duly authorized to commit Bidder. An unsigned **BID RESPONSE** may be disqualified.

### **Order of Documents:**

The items shall be placed in the following order. Bids may be disqualified from further consideration if Bidder does not conform to this requirement.

#### **1<sup>st</sup> - BID RESPONSE**

**2<sup>nd</sup> - "Exhibit A"** - Technical Specifications and literature illustrating Bidder's proposed product(s).

**3<sup>rd</sup> - "Exhibit B"** - A letter from the manufacturer certifying that Bidder is an authorized representative of the manufacturer for the product(s) being proposed and that any warranty requirements provided for herein will be performed favorably in their behalf.

**4<sup>th</sup> - "Exhibit C"** - A copy of Bidder's warranty, indicating the terms, conditions, and limitations of said warranty.

**5<sup>th</sup> - "Exhibit D"** - All addenda must be signed and placed in date and time order.

## **CARSON CITY PURCHASING AND CONTRACTS TERMS AND CONDITIONS**

6<sup>th</sup> - "Exhibit E" - **BID RESPONSE** additional space on company letterhead

7<sup>th</sup> - "Exhibit F"- Supplemental materials

8<sup>th</sup> - "Exhibit G" - **EXCEPTION SUMMARY** additional space on company letterhead

### **SEALED BIDS:**

Bidder shall submit their **SEALED BID** to **CARSON CITY PURCHASING and CONTRACTS**, 201 North Carson Street Suite 3, Carson City, NV 89701 by the date and time set for receipt of **SEALED BIDS** which is indicated on page one of this **REQUEST FOR BID**.

The **SEALED BID** shall consist of

one (1) original **BID RESPONSE** which includes all exhibits (clearly marked on the front outside cover as the original with the number and title of this **REQUEST FOR BID** as well as Bidder's name, address, e-mail address, telephone number, and fax number); three (3) copies of the **BID RESPONSE** which includes all exhibits (clearly marked on the front outside cover as a copy with the number and title of this **REQUEST FOR BID** as well as Bidder's name, address, e-mail address, telephone number, and fax number); and

one (1) CD which includes the **BID RESPONSE** and all exhibits (clearly marked with the number and title of this **REQUEST FOR BID** as well as Bidder's name, address, e-mail address, telephone number, and fax number)

placed in a sealed envelope/package/box (clearly marked with number and title of this **REQUEST FOR BID** as well as Bidder's name, address, e-mail address, telephone number, and fax number).

Carson City will not be responsible for the premature opening of a bid not properly addressed or identified.

It is Bidder's sole responsibility to see that their **BID RESPONSE** is received at the place, date, and time specified. Carson City assumes no responsibility for errant delivery of any **BID RESPONSE** relegated to a courier agent who fails to deliver in accordance with the specified receiving point and time herein stated.

A **BID RESPONSE** received after the date and time set for receipt will be rejected and

## **CARSON CITY PURCHASING AND CONTRACTS TERMS AND CONDITIONS**

disqualified from consideration.

A **BID RESPONSE** that is sent by telephone, facsimile, or e-mail shall not be accepted and will be disregarded if received.

### **MODIFICATION OF BIDS:**

Bids may be modified by written notice received by Carson City Purchasing and Contracts prior to the date and time set for receipt of **SEALED BIDS** which is indicated on page one of this **REQUEST FOR BID**. Notice of modification by telephone, facsimile, or e-mail will not be accepted and will be disregarded if received. Notice of modification received after the date and time set for receipt of **SEALED BIDS** will not be considered.

### **NO BID:**

If Bidder chooses not to bid, but wishes to receive information regarding the outcome of this **REQUEST FOR BID**; Bidder must write **NO BID** across the face of the first page of the **BID RESPONSE**; complete the **BIDDER INFORMATION** in the **BID RESPONSE**; and fax that page to **CARSON CITY PURCHASING and CONTRACTS** at 775-887-2107.

### **WITHDRAWAL OF BIDS:**

Bids may be withdrawn without penalty by written notice received by Carson City Purchasing and Contracts prior to the date and time set for receipt of **SEALED BIDS** which is indicated on page one of this **REQUEST FOR BID**. Notice of withdrawals by telephone, facsimile, or e-mail will not be accepted and will be disregarded if received. Notice of withdrawals received after the date and time set for receipt of **SEALED BIDS** will not be considered.

### **BID EVALUATION:**

The evaluation of bids and the determination as to the quality of the product(s) and/or service(s) offered shall be the responsibility of Carson City and will be based on information furnished by Bidder as well as other information obtained. Responses to this **REQUEST FOR BID** will be the primary source of information used in the evaluation process.

Carson City reserves the right to perform an investigation to determine the ability of Bidder to perform in accordance with the provisions of this **REQUEST FOR BID**. Carson City may contact any current users of a Bidder's product(s) and/or service(s); solicit information from any available source concerning any aspect of the bid; and seek and review any other

# CARSON CITY PURCHASING AND CONTRACTS TERMS AND CONDITIONS

information it deems pertinent to the evaluation process.

Carson City reserves the right to meet with bidders to discuss or clarify their **BID RESPONSES**, to request additional information, and to allow corrections of errors or omissions. All expenses incurred as a result of said meeting shall be the responsibility of Bidder and shall not be chargeable to Carson City.

Deviations, modifications, and/or alternates to this **REQUEST FOR BID** shall be given consideration in the evaluation process, provided each deviation, modification and/or alternate shall be recorded on the **EXCEPTION SUMMARY**.

## **The following categories will be evaluated in the selection process:**

- **Quality of the product(s) or service(s)**
- **Delivery Schedule**
- **Warehouse/Store Location**

## **COLLUSION:**

Pursuant to Nevada Revised Statute 332.820 (1), any agreement or collusion among bidders or prospective bidders in restraint of freedom of competition by agreement to bid a fixed price, or otherwise, shall render the bids of such bidders void.

## **ADVANCE DISCLOSURES:**

Pursuant to Nevada Revised Statute 332.820 (2), advance disclosures of proprietary information or any other information to any particular bidder which would give that particular bidder any advantage over any other interested bidder in advance of the opening of bids, whether in response to advertising or an informal request for bids, made or permitted by a member of the governing body or an employee or representative thereof, shall operate to void all bids received in response to that particular request for bids.

## **REJECTION OF BID:**

Pursuant to Nevada Revised Statute 332.075, any or all bids received in response to a request for bids may be rejected by the governing body or its authorized representative if such governing body or its authorized representative determines that any such bidder is not responsive or responsible or that the quality of the services, supplies, materials, equipment or labor offered does not conform to requirements or if the public interest would be served by such a rejection.

# CARSON CITY PURCHASING AND CONTRACTS TERMS AND CONDITIONS

## AWARD OF CONTRACT:

Carson City will award the bid / contract to the lowest responsive and responsible bidder(s), as determined by Carson City pursuant to the provisions of Chapter 332 of the Nevada Revised Statutes.

Pursuant to Nevada Revised Statute 332.065 (1), the lowest responsive and responsible may be judged on the basis of (a) Price; (b) Conformance to the specifications; (c) Qualifications, (d) Past performance; (e) Performance or delivery date; (f) Quality and utility of services, supplies, materials, or equipment offered and the adaptability of those services, supplies, materials or equipment to the required purpose of the contract; (g) The best interest of the public; and (h) Such other criteria as may be set forth by the governing body or its authorized representative in the advertisement or request for bids, as applicable, that pertains to the contract.

Pursuant to Nevada Revised Statute 332.065 (2), the governing body or its authorized representative (a) shall give preference to recycled products if: (1) The product meets the applicable standards; (2) The product can be substituted for a comparable nonrecycled product; and (3) The product costs no more than a comparable nonrecycled product.

Pursuant to Nevada Revised Statute 332.085, in determining the responsibility of any bidder, the governing body or its authorized representative shall consider the possession of and limit on any required license of the bidder; and may consider the financial responsibility of the bidder; experience of the bidder; adequacy of the equipment of the bidder; past performance of the bidder; performance or delivery date; and ability of the bidder to perform the contract.

Prompt payment discounts will be considered in bid / contract award recommendation only if discount period is fifteen (15) or more calendar days. Discount period will be computed from the date Carson City acknowledges that the delivery and/or performance meets the requirements of this **REQUEST FOR BID** or from the date the correct invoice is received by the appropriate Carson City department/division accounts payable clerk, whichever is the latter date. Payment is deemed to be made on the date payment is mailed to Bidder.

Should identical low, responsive and responsible bids be received from two (2) or more Bidders; Kim Belt, Purchasing and Contracts Manager, shall notify all parties involved in the tie and may, at her option, exercise one of the following tie breaking methods unless another alternative is apparent and prudent: (1) Tie Bid (two vendors): The Purchasing and Contracts Management Assistant, with a witness present, may flip a coin with heads representing Bidder whose tie bid was first received by Carson City. If the toss is heads, the recommendation will be to this Bidder; if tails, the recommendation will be made in



## **CARSON CITY PURCHASING AND CONTRACTS TERMS AND CONDITIONS**

favor of the second tied Bidder. (2) Tie Bid (two or more vendors): Should there be two or more low, responsive and responsible tie bids where representatives of Bidders wish to participate in the tie breaking process, the Purchasing and Contracts Management Assistant shall set a mutually agreed upon time where, in her office, she shall shuffle a new deck of playing cards and have each Bidder's representative cut the cards. The tie Bidder who cuts the highest card (with Ace high) shall be recommended for bid / contract award.

A Purchase Order or Contract mailed or otherwise furnished by Carson City Purchasing and Contracts to Bidder is a binding contract without further action by either party.

Pursuant to Nevada Revised Statute 332.095, no contract awarded may be assigned to any other person without the consent of the governing body or its authorized representative. No contract awarded or any portion thereof may be assigned to any person who was declared by the governing body or its authorized representative not to be a responsible person to perform the particular contract.

Bidders will receive written notification of the Bidder(s) who has been recommended to be awarded this **REQUEST FOR BID**.

Pursuant to Nevada Revised Statute 332.065 (3), if after the lowest responsive and responsible bidder has been awarded the contract, during the term of the contract he does not supply goods or services in accordance with the bid specifications, or if he repudiates the contract, the governing body or its authorized representative may reaward the contract to the next lowest responsive and responsible bidder without requiring that new bids be submitted. Reawarding the contract to the next lowest responsive and responsible bidder is not a waiver of any liability of the initial bidder awarded the contract.

### **APPEAL BY UNSUCCESSFUL BIDDER:**

Pursuant to Nevada Revised Statute 332.068, a person who submits a bid on a contract that is required to be advertised pursuant to paragraph (a) subsection 1 of Nevada Revised Statute 332.039 may, after the bids are opened and within the period specified by the governing body or its authorized representative, file with the governing body or its authorized representative a notice of protest regarding the awarding of the contract.

Should an unsuccessful Bidder choose to appeal the recommendation, Bidder shall do so by providing a notice of protest which must include a written statement setting forth with specificity the reasons the person filing the notice believes the applicable provisions of law were violated to Kim Belt, Purchasing and Contracts Manager, by not later than five (5) working days prior to the date scheduled for **AWARD** which is indicated on page one of this **REQUEST FOR BID**.

## **CARSON CITY PURCHASING AND CONTRACTS TERMS AND CONDITIONS**

A person filing a notice of protest may be required by the governing body or its authorized representative, at the time the notice of protest is filed, to post a bond with a good and solvent surety authorized to do business in this State or submit other security, in a form approved by the governing body or its authorized representative, to the governing body or its authorized representative who shall hold the bond or other security until a determination is made on the protest. A bond posted or other security submitted with a notice of protest must be in an amount equal to the lesser of: Twenty-Five percent (25%) of the total value of the bid submitted by the person filing the notice of protest; or Two Hundred Fifty Thousand Dollars (\$250,000.00).

A notice of protest filed in accordance with the provisions of this section operates as a stay of action in relation to the awarding of any contract until a determination is made by the governing body or its authorized representative on the protest.

A person who submits an unsuccessful bid may not seek any type of judicial intervention until the governing body or its authorized representative has made a determination on the protest and awarded the contract.

A governing body or its authorized representative is not liable for any costs, expenses, attorney's fees, loss of income or other damages sustained by a person who submits a bid, whether or not the person files a notice of protest pursuant to this section.

If the protest is upheld, the bond posted or other security submitted with the notice of protest must be returned to the person who posted the bond or submitted the security. If the protest is rejected, a claim may be made against the bond or other security by the governing body or its authorized representative in an amount equal to the expenses incurred by the governing body or its authorized representative because of the unsuccessful protest. Any money remaining after the claim has been satisfied must be returned to the person who posted the bond or submitted the security.

No protest shall be considered unless these procedures have been followed.

### **TIMELINESS OF BILLING SUBMISSION:**

The parties agree that timeliness of billing is of the essence to the bid / contract award and recognize that Carson City is on a fiscal year which is defined as the period beginning July 1 and ending June 30 of the following year. All billings for dates of service prior to July 1 must be submitted to Carson City no later than the first Friday in August of the same year. A billing submitted after the first Friday in August will subject Bidder to an administrative fee not to exceed \$100.00. The parties hereby agree this is a reasonable estimate of the additional costs to Carson City of processing the billing as a stale claim and that this amount will be deducted from the stale claim payment due to Bidder.

# CARSON CITY PURCHASING AND CONTRACTS TERMS AND CONDITIONS

## **PAYMENT:**

Carson City agrees to provide payment to Bidder within thirty (30) calendar days from the date Carson City acknowledges that the delivery and/or performance meets the requirements of this **REQUEST FOR BID** or from the date the correct, complete, and descriptive invoice in the awarded amount is received by the appropriate Carson City department/division accounts payable clerk, whichever is the latter date.

Discount period will be computed from the date Carson City acknowledges that the delivery and/or performance meets the requirements of this **REQUEST FOR BID** or from the date the correct, complete, and descriptive invoice is received by the appropriate Carson City department/division accounts payable clerk, whichever is the latter date. Payment is deemed to be made on the date payment is mailed to Bidder.

## **PRICE REDUCTIONS:**

In the event that during the term of the bid / contract award Bidder shall reduce any or all prices charged to any or all customers other than Carson City for the same product(s) and/or service(s) of the equivalent quantity, quality, delivery, performance and warranty, as said product(s) and/or service(s) specified herein, Bidder shall make an equivalent reduction for Carson City.

## **LIQUIDATED DAMAGES:**

Liquidated damages shall not cover or preclude Carson City from claiming and collecting damages on account of delay, price changes, loss of other contracts, loss of income, and the inability of Carson City to fulfill other damages direct or consequential arising out of the failure of Bidder to perform under the terms, conditions and requirements of this **REQUEST FOR BID**.

## **NOTICE:**

All notices or other communications required or permitted to be given under this **REQUEST FOR BID** shall be in writing and shall be deemed to have been duly given if delivered personally in hand, by e-mail with simultaneous regular mail, by telephonic facsimile with simultaneous regular mail, or by certified mail, return receipt requested, postage prepaid on the date posted, and addressed to the other party at the address specified below.

Notice to Bidder shall be addressed to the contact person listed in **BIDDER INFORMATION**.

# CARSON CITY PURCHASING AND CONTRACTS TERMS AND CONDITIONS

Notice to Carson City shall be addressed to:

Carson City Purchasing and Contracts  
Kim Belt, Purchasing and Contracts Manager  
201 North Carson Street Suite 3  
Carson City, NV 89701  
775-283-7137 / FAX 887-2107  
[kbelt@carson.org](mailto:kbelt@carson.org)

## **CONTRACT TERMINATION:**

### **Termination Without Cause:**

Any discretionary or vested right of renewal notwithstanding, this **REQUEST FOR BID** may be terminated upon written notice by mutual consent of both parties or unilaterally by either party without cause.

### **Termination for Nonappropriation:**

Nevada Revised Statute 360.800 (1) (a) provides for the termination if the governing body fails to appropriate money for the ensuing fiscal year for payment of the amounts then due. Carson City may terminate this Contract, and Bidder waives any and all claim(s) for damages, effective immediately upon receipt of written notice (or any date specified therein) if for any reason the funding is not appropriated or is withdrawn, limited, or impaired.

### **Cause Termination for Default or Breach:**

A default or breach may be declared with or without termination. This bid / contract award may be terminated by either party upon thirty (30) calendar days written notice of default or breach to the other party as follows: (1) If Bidder fails to provide or satisfactorily perform any of the conditions, work, deliverables, goods, or services called for by this **REQUEST FOR BID** within the time requirements specified in this **REQUEST FOR BID** or within any granted extension of those time requirements; or (2) If any state, county, city or federal license, authorization, waiver, permit, qualification or certification required by statute, ordinance, law, or regulation to be held by Bidder to provide the goods or services required by this **REQUEST FOR BID** is for any reason denied, revoked, debarred, excluded, terminated, suspended, lapsed, or not renewed; or (3) If Bidder becomes insolvent, subject to receivership, or becomes voluntarily or involuntarily subject to the jurisdiction of the bankruptcy court; or (4) If Carson City materially breaches any material duty under this **REQUEST FOR BID** and any such breach impairs Bidder's ability to perform; or (5) If it

## **CARSON CITY PURCHASING AND CONTRACTS TERMS AND CONDITIONS**

is found by Carson City that any quid pro quo or gratuities in the form of money, services, entertainment, gifts, or otherwise were offered or given by Bidder, or any agent or representative of Bidder, to any officer or employee of Carson City with a view toward securing a contract or securing favorable treatment with respect to awarding, extending, amending, or making any determination with respect to the performing of such contract; or (6) If it is found by Carson City that Bidder has failed to disclose any material conflict of interest relative to the performance of this **REQUEST FOR BID**.

### **Time to Correct:**

Termination upon a declared default or breach may be exercised only after service of formal thirty (30) calendar days written notice, and the subsequent failure of the defaulting party within fifteen (15) calendar days of that notice to provide evidence, satisfactory to the aggrieved party, showing that the declared default or breach has been corrected.

### **Winding Up Affairs Upon Termination:**

In the event of termination of this bid / contract award for any reason, the parties agree that the provisions of this paragraph survive termination: (1) the parties shall account for and properly present to each other all claims for fees and expenses and pay those which are undisputed and otherwise not subject to set off under this bid / contract award. Neither party may withhold performance of winding up provisions solely based on nonpayment of fees or expenses accrued up to the time of termination; (2) Bidder shall satisfactorily complete work in progress at the agreed rate (or a pro rata basis if necessary) if so requested by Carson City; (3) Bidder shall execute any documents and take any actions necessary to effectuate an assignment of this bid / contract award if so requested by Carson City; (4) Bidder shall preserve, protect, and promptly deliver into Carson City's possession all proprietary information in accordance with **Carson City Ownership of Proprietary Information**.

### **REMEDIES:**

Except as otherwise provided for by law or this **REQUEST FOR BID**, the rights and remedies of the parties shall not be exclusive and are in addition to any other rights and remedies provided by law or equity, including, without limitation, actual damages, and to a prevailing party reasonable attorneys' fees and costs. The parties agree that, in the event a lawsuit is filed and a party is awarded attorney's fees by the court, for any reason, the amount of recoverable attorney's fees shall not exceed the rate of \$125 per hour. Carson City may set off consideration against any unpaid obligation of Bidder to Carson City.

## **CARSON CITY PURCHASING AND CONTRACTS TERMS AND CONDITIONS**

### **LIMITED LIABILITY:**

Carson City will not waive and intends to assert available Nevada Revised Statutes Chapter 41 liability limitations in all cases. Contract liability of both parties shall not be subject to punitive damages. Liquidated damages shall not apply unless otherwise specified in the incorporated attachments. Damages for any Carson City breach shall never exceed the amount of funds appropriated for payment under this **REQUEST FOR BID**, but not yet paid to Bidder, for the fiscal year budget in existence at the time of the breach. Bidder's tort liability shall not be limited.

### **FORCE MAJEURE:**

Neither party shall be deemed to be in violation of this **REQUEST FOR BID** if it is prevented from performing any of its obligations hereunder due to strikes, failure of public transportation, civil or military authority, act of public enemy, accidents, fires, explosions, or acts of God, including, without limitation, earthquakes, floods, winds, or storms. In such an event the intervening cause must not be through the fault of the party asserting such an excuse, and the excused party is obligated to promptly perform in accordance with the terms of the bid / contract award after the intervening cause ceases.

### **INDEMNIFICATION:**

To the extent permitted by law, including, but not limited to, the provisions of Nevada Revised Statutes Chapter 41, each party shall indemnify, hold harmless and defend, not excluding the other's right to participate, the other party from and against all liability, claims, actions, damages, losses, and expenses, including but not limited to reasonable attorney's fees and costs, arising out of any alleged negligent or willful acts or omissions of the indemnifying party, its officers, employees and agents. Such obligation shall not be construed to negate, abridge, or otherwise reduce any other right or obligation of the indemnity which would otherwise exist as to any party or person described in this paragraph.

Except as otherwise provided below, the indemnifying party shall not be obligated to provide a legal defense to the indemnified party, nor reimburse the indemnified party for the same, for any period occurring before the indemnified party provides written notice of the pending claim(s) or cause(s) of action to the indemnifying party, along with: a written request for a legal defense for such pending claim(s) or cause(s) of action; and a detailed explanation of the basis upon which the indemnified party believes that the claim or cause of action asserted against the indemnified party implicates the culpable conduct of the indemnifying party, its officers, employees, and/or agents.

After the indemnifying party has begun to provide a legal defense for the indemnified party,

## **CARSON CITY PURCHASING AND CONTRACTS TERMS AND CONDITIONS**

the indemnifying party shall not be obligated to fund or reimburse any fees or costs provided by any additional counsel for the indemnified party, including counsel through which the indemnified party might voluntarily choose to participate in its defense of the same matter.

After the indemnifying party has begun to provide a legal defense for the indemnified party, the indemnifying party shall be obligated to reimburse the reasonable attorney's fees and costs incurred by the indemnified party during the initial thirty (30) day period of the claim or cause of action, if any, incurred by separate counsel.

### **INDEPENDENT CONTRACTOR:**

An independent contractor is a natural person, firm or corporation who agrees to perform services for a fixed price according to his or its own methods and without subjection to the supervision or control of the other contracting party, except as to the results of the work, and not as to the means by which the services are accomplished.

It is mutually agreed that Bidder is associated with Carson City only for the purposes and to the extent specified in this **REQUEST FOR BID**, and in respect to performance of the contracted services pursuant to this **REQUEST FOR BID**. Bidder is and shall be an independent contractor and, subject only to the terms of this **REQUEST FOR BID**, shall have the sole right to supervise, manage, operate, control, and direct performance of the details incident to its duties under this **REQUEST FOR BID**.

Nothing contained in this **REQUEST FOR BID** shall be deemed or construed to create a partnership or joint venture, to create relationships of an employer-employee or principal-agent, or to otherwise create any liability for Carson City whatsoever with respect to the indebtedness, liabilities, and obligations of Bidder or any other party.

Bidder shall indemnify and hold Carson City harmless from, and defend Carson City against, any and all losses, damages, claims, costs, penalties, liabilities, expenses arising out of or incurred in any way because of, but not limited to, Bidder's obligations or legal duties regarding any taxes, fees, assessments, benefits, entitlements, notice of benefits, employee's eligibility to work, to any third party, subcontractor, employee, state, local or federal governmental entity.

Neither Bidder nor its employees, agents, or representatives shall be considered employees, agents, or representatives of Carson City.

### **INSURANCE REQUIREMENTS:**

Unless expressly waived in writing by Carson City, Bidder, as an independent contractor

## **CARSON CITY PURCHASING AND CONTRACTS TERMS AND CONDITIONS**

and not an employee of Carson City, must carry policies of insurance in amounts specified and pay all taxes and fees incident hereunto. Carson City shall have no liability except as specifically provided in the **REQUEST FOR BID**. Bidder shall not commence work before: (1) Bidder has provided the required evidence of insurance to Carson City Purchasing and Contracts, and (2) Carson City has approved the insurance policies provided by Bidder.

Prior approval of the insurance policies by Carson City shall be a condition precedent to any payment of consideration under this **REQUEST FOR BID** and Carson City's approval of any changes to insurance coverage during the course of performance shall constitute an ongoing condition subsequent this **REQUEST FOR BID**. Any failure of the Carson City to timely approve shall not constitute a waiver of the condition.

### **Insurance Coverage:**

Bidder shall, at Bidder's sole expense, procure, maintain and keep in force for the duration of the **REQUEST FOR BID** the following insurance conforming to the minimum requirements specified below. Unless specifically specified herein or otherwise agreed to by Carson City, the required insurance shall be in effect prior to the commencement of work by Bidder and shall continue in force as appropriate until the latter of: (1) Final acceptance by Carson City of the completion of this **REQUEST FOR BID**; or (2) Such time as the insurance is no longer required by Carson City under the terms of this **REQUEST FOR BID**.

Any insurance or self-insurance available to Carson City shall be in excess of and non-contributing with any insurance required from Bidder. Bidder's insurance policies shall apply on a primary basis. Until such time as the insurance is no longer required by Carson City, Bidder shall provide Carson City with renewal or replacement evidence of insurance no less than thirty (30) calendar days before the expiration or replacement of the required insurance. If at any time during the period when insurance is required by the **REQUEST FOR BID**, an insurer or surety shall fail to comply with the requirements of this **REQUEST FOR BID**, as soon as Bidder has knowledge of any such failure, Bidder shall immediately notify Carson City and immediately replace such insurance or bond with an insurer meeting the requirements.

### **General Requirements:**

**Certificate Holder:** Each liability insurance policy shall list Carson City c/o Carson City Purchasing and Contracts, 201 N. Carson Street Suite 3, Carson City, NV 89701 as a certificate holder.



## **CARSON CITY PURCHASING AND CONTRACTS TERMS AND CONDITIONS**

**Additional Insured:** By endorsement to the general liability insurance policy evidenced by Bidder, The City and County of Carson City, Nevada, its officers, employees and immune contractors shall be named as additional insureds for all liability arising from the **REQUEST FOR BID.**

**Waiver of Subrogation:** Each liability insurance policy shall provide for a waiver of subrogation as to additional insureds.

**Cross-Liability:** All required liability policies shall provide cross-liability coverage as would be achieved under the standard ISO separation of insureds clause.

**Deductibles and Self-Insured Retentions:** Insurance maintained by Bidder shall apply on a first dollar basis without application of a deductible or self-insured retention unless otherwise specifically agreed to by Carson City. Such approval shall not relieve Bidder **OR** from the obligation to pay any deductible or self-insured retention. Any deductible or self-insured retention shall not exceed \$5,000 per occurrence, unless otherwise approved by Carson City.

**Policy Cancellation:** Except for ten (10) calendar days notice for non-payment of premium, each insurance policy shall be endorsed to state that; without thirty (30) calendar days prior written notice to Carson City Purchasing and Contracts, the policy shall not be canceled, non-renewed or coverage and /or limits reduced or materially altered, and shall provide that notices required by this paragraph shall be sent by certified mail to the address shown.

**Approved Insurer:** Each insurance policy shall be: (1) Issued by insurance companies authorized to do business in the State of Nevada or eligible surplus lines insurers acceptable to the State and having agents in Nevada upon whom service of process may be made, and (2) currently rated by A.M. Best as AA-VII@ or better.

**Evidence of Insurance:** Prior to commencement of work, Bidder must provide the following documents to Carson City Purchasing and Contracts, 201 North Carson Street Suite 3, Carson City, NV 89701: (1) Certificate of Insurance: The Acord 25 Certificate of Insurance form or a form substantially similar must be submitted to Carson City Purchasing and Contracts to evidence the insurance policies and coverages required of Bidder. (2) Additional Insured Endorsement: An Additional Insured Endorsement (CG20 10 or C20 26), signed by an authorized insurance company representative, must be submitted to Carson City Purchasing and Contracts to evidence the endorsement of Carson City as an additional insured. (3) Schedule of Underlying Insurance Policies: If Umbrella or Excess policy is evidenced to comply with minimum limits, a copy of the Underlyer Schedule from the Umbrella or Excess insurance policy may be required.

# **CARSON CITY PURCHASING AND CONTRACTS TERMS AND CONDITIONS**

**Review and Approval:** Documents specified above must be submitted for review and approval by Carson City Purchasing and Contracts prior to the commencement of work by Bidder. Neither approval by Carson City nor failure to disapprove the insurance furnished by Bidder shall relieve Bidder of Bidder's full responsibility to provide the insurance required by this **REQUEST FOR BID**. Compliance with the insurance requirements of this **REQUEST FOR BID** shall not limit the liability of Bidder or its sub-contractors, employees or agents to Carson City or others, and shall be in addition to and not in lieu of any other remedy available to Carson City under this **REQUEST FOR BID** or otherwise. Carson City reserves the right to request and review a copy of any required insurance policy or endorsement to assure compliance with these requirements.

## **COMMERCIAL GENERAL LIABILITY INSURANCE:**

Minimum Limits required:

Two Million Dollars (\$2,000,000.00) - General Aggregate

Two Million Dollars (\$2,000,000.00) - Products & Completed Operations Aggregate

One Million Dollars (\$1,000,000.00) - Each Occurrence

Coverage shall be on an occurrence basis and shall be at least as broad as ISO 1996 form CG 00 01 (or a substitute form providing equivalent coverage); and shall cover liability arising from premises, operations, independent contractors, completed operations, personal injury, products, civil lawsuits, Title VII actions and liability assumed under an insured contract (including the tort liability of another assumed in a business contract).

## **BUSINESS AUTOMOBILE LIABILITY INSURANCE:**

Minimum Limit required:

One Million Dollars (\$1,000,000) per occurrence for bodily injury and property damage

Coverage shall be for "any auto", including owned, non-owned and hired vehicles. The policy shall be written on ISO form CA 00 01 or a substitute providing equivalent liability coverage. If necessary, the policy shall be endorsed to provide contractual liability coverage.

## **PROFESSIONAL LIABILITY INSURANCE:**

Minimum Limit required: One Million Dollars (\$1,000,000.00)

# CARSON CITY PURCHASING AND CONTRACTS TERMS AND CONDITIONS

Retroactive date: Prior to commencement of the performance of this Contract

Discovery period: Three (3) years after termination date of this Contract.

A certified copy of this policy may be required.

## **WORKERS' COMPENSATION AND EMPLOYER'S LIABILITY INSURANCE:**

Bidder shall provide workers' compensation insurance as required by Nevada Revised Statutes Chapters 616A through 616D inclusive and Employer's Liability insurance with a minimum limit of \$500,000 each employee per accident for bodily injury by accident or disease.

Bidder may, in lieu of furnishing a certificate of an insurer, provide an affidavit indicating that Bidder is a sole proprietor; that Bidder will not use the services of any employees in the performance of this **REQUEST FOR BID**; that Bidder has elected to not be included in the terms, conditions, and provisions of Nevada Revised Statutes Chapters 616A-616D, inclusive; and that Bidder is otherwise in compliance with the terms, conditions, and provisions of Nevada Revised Statutes Chapters 616A-616D, inclusive.

## **BUSINESS LICENSE:**

If required, Bidder shall not commence work before Bidder has provided a copy of his Carson City business license to Carson City Purchasing and Contracts.

The Carson City business license shall continue in force until the latter of: (1) final acceptance by Carson City of the completion of this **REQUEST FOR BID**; or (2) such time as the Carson City business license is no longer required by Carson City under the terms of this **REQUEST FOR BID**.

## **COMPLIANCE WITH LEGAL OBLIGATIONS:**

Bidder shall procure and maintain for the duration of this **REQUEST FOR BID** any state, county, city, or federal license, authorization, waiver, permit, qualification or certification required by statute, ordinance, law, or regulation to be held by Bidder to provide the goods or services of this **REQUEST FOR BID**. Bidder will be responsible to pay all taxes, assessments, fees, premiums, permits, and licenses required by law. Real property and personal property taxes are the responsibility of Bidder in accordance with Nevada Revised Statutes 361.157 and 361.159. Bidder agrees to be responsible for payment of any such government obligations not paid by its subcontractors during performance of this **REQUEST FOR BID**. Carson City may set-off against consideration

## **CARSON CITY PURCHASING AND CONTRACTS TERMS AND CONDITIONS**

due any delinquent government obligation.

### **WAIVER OF BREACH:**

Failure to declare a breach or the actual waiver of any particular breach of the **REQUEST FOR BID** or its material or nonmaterial terms by either party shall not operate as a waiver by such party of any of its rights or remedies as to any other breach.

### **SEVERABILITY:**

If any provision contained in this **REQUEST FOR BID** is held to be unenforceable by a court of law or equity, this **REQUEST FOR BID** shall be construed as if such provision did not exist and the nonenforceability of such provision shall not be held to render any other provision or provisions of this **REQUEST FOR BID** unenforceable.

### **ASSIGNMENT/DELEGATION:**

To the extent that any assignment of any right under this **REQUEST FOR BID** changes the duty of either party, increases the burden or risk involved, impairs the chances of obtaining the performance of this **REQUEST FOR BID**, attempts to operate as a novation, or includes a waiver or abrogation of any defense to payment Carson City, such offending portion of the assignment shall be void, and shall be a breach of this **REQUEST FOR BID**. Bidder shall neither assign, transfer nor delegate any rights, obligations or duties under this **REQUEST FOR BID** without the prior written approval of Carson City.

### **CARSON CITY OWNERSHIP OF PROPRIETARY INFORMATION:**

Any files, reports, histories, studies, tests, manuals, instructions, photographs, negatives, blue prints, plans, maps, data, system designs, computer programs, computer codes, and computer records (which are intended to be consideration under the bid / contract award), or any other documents or drawings, prepared or in the course of preparation by Bidder (or its subcontractors) in performance of its obligations under this **REQUEST FOR BID** shall be the exclusive property of Carson City and all such materials shall be delivered into Carson City possession by Bidder upon completion, termination, or cancellation of this **REQUEST FOR BID**.

Bidder shall not use, willingly allow, or cause to have such materials used for any purpose other than performance of Bidder's obligations under this **REQUEST FOR BID** without the prior written consent of Carson City. Notwithstanding the foregoing, Carson City shall

## **CARSON CITY PURCHASING AND CONTRACTS TERMS AND CONDITIONS**

have no proprietary interest in any materials licensed for use by Carson City that are subject to patent, trademark or copyright protection.

Carson City shall be permitted to retain copies, including reproducible copies, of Bidder's drawings, specifications, and other documents for information and reference in connection with this **REQUEST FOR BID**.

Bidder's drawings, specifications and other documents shall not be used by Carson City or others without expressed permission of Bidder.

### **PUBLIC RECORDS:**

Pursuant to Nevada Revised Statute 239.010, information or documents received from Bidder may be open to public inspection and copying. Carson City will have the duty to disclose unless a particular record is made confidential by law or a common law balancing of interests. Bidder may clearly label individual documents as a "trade secret" or "confidential" in accordance with Nevada Revised Statute 332.061, provided that Bidder thereby agrees to indemnify and defend Carson City for honoring such a designation. The failure to so label any document that is released by Carson City shall constitute a complete waiver of any and all claims for damages caused by any release of the records.

### **CONFIDENTIALITY:**

Bidder shall keep confidential all information, in whatever form, produced, prepared, observed or received by Bidder to the extent that such information is confidential by law or otherwise required by this **REQUEST FOR BID**.

### **FEDERAL FUNDING:**

In the event federal funds are used for payment of all or part of this **REQUEST FOR BID**: (1) Bidder certifies, by signing this **REQUEST FOR BID**, that neither it nor its principals are presently debarred, suspended, proposed for debarment, declared ineligible, or voluntarily excluded from participation in this transaction by any federal department or agency. (2) This certification is made pursuant to the regulations implementing Executive Order 12549, Debarment and Suspension, 28 C.F.R. pt. 67, § 67.510, as published as pt. VII of the May 26, 1988, Federal Register (pp. 19160-19211), and any relevant program-specific regulations. (3) This provision shall be required of every subcontractor receiving any payment in whole or in part from federal funds. (4) Bidder and its subcontractors shall comply with all terms, conditions, and requirements of the Americans with Disabilities Act of 1990 (P.L. 101-136), 42 U.S.C. 12101, as amended, and regulations adopted thereunder contained in 28 C.F.R. 26.101-36.999, inclusive, and any relevant program-specific regulations. (5) Bidder and its subcontractors shall comply with the requirements of

## **CARSON CITY PURCHASING AND CONTRACTS TERMS AND CONDITIONS**

the Civil Rights Act of 1964, as amended, the Rehabilitation Act of 1973, P.L. 93-112, as amended, and any relevant program-specific regulations, and shall not discriminate against any employee or offeror for employment because of race, national origin, creed, color, sex, religion, age, disability or handicap condition (including AIDS and AIDS-related conditions.)

### **LOBBYING:**

The parties agree, whether expressly prohibited by federal law, or otherwise, that no funding associated with this **REQUEST FOR BID** will be used for any purpose associated with or related to lobbying or influencing or attempting to lobby or influence for any purpose the following: (1) Any federal, state, county or local agency, legislature, commission, counsel or board; (2) Any federal, state, county or local legislator, commission member, counsel member, board member, or other elected official; or (3) Any officer or employee of any federal, state, county or local agency; legislature, commission, counsel or board.

### **GENERAL WARRANTY:**

Bidder warrants that all services, deliverables, and/or work product under this **REQUEST FOR BID** shall be completed in a workmanlike manner consistent with standards in the trade, profession, or industry; shall conform to or exceed the specifications as set forth in the incorporated attachments; and shall be fit for ordinary use, of good quality, with no material defects.

### **PROPER AUTHORITY:**

The parties hereto represent and warrant that the person executing this **REQUEST FOR BID** on behalf of each party has full power and authority to enter into this Contract. Bidder acknowledges that this bid / contract award is effective only after approval by the Carson City Board of Supervisors and only for the period of time specified in the **REQUEST FOR BID**. Any services performed by Bidder before this bid / contract award is effective or after it ceases to be effective are performed at the sole risk of Bidder.

### **ARBITRATION:**

Any controversy of claims arising out of or relating to this Contract, or the breach thereof, provided both parties agree, may be settled by arbitration in accordance with the Commercial Arbitration Rules of the American Arbitration Association and judgment upon the award rendered by the Arbitrator(s) may be entered in any court having jurisdiction thereof.

# CARSON CITY PURCHASING AND CONTRACTS TERMS AND CONDITIONS

## **GOVERNING LAW; JURISDICTION:**

This Contract and the rights and obligations of the parties hereto shall be governed by, and construed according to, the laws of the State of Nevada, without giving effect to any principle of conflict-of-law that would require the application of the law of any other jurisdiction. Bidder consents and agrees to the jurisdiction of the courts of the State of Nevada located in Carson City, Nevada for enforcement of this Contract.

## **ENTIRE CONTRACT AND MODIFICATION:**

Once the Carson City Board of Supervisors has awarded this **REQUEST FOR BID** (which includes the **NOTICE TO BIDDERS, SPECIFICATIONS, TERMS AND CONDITIONS, BID RESPONSE,** and all **EXHIBITS**), their award and this **REQUEST FOR BID** constitutes the entire Contract between Carson City and Bidder and is intended as a complete and exclusive statement of the promises, representations, negotiations, and discussions that may have been made.

Unless an integrated attachment to this Contract specifically displays a mutual intent to amend a particular part of this Contract, general conflicts in language between any such attachment and this Contract shall be construed consistent with the terms of this Contract.

Unless otherwise expressly authorized by the terms of this Contract, no modification or amendment to this Contract shall be binding upon the parties unless the same is in writing and signed by the respective parties hereto and approved by the Carson City Board of Supervisors.

**\* \* \* END OF TERMS & CONDITIONS \* \* \***

**CARSON CITY PURCHASING AND CONTRACTS  
BID RESPONSE**

Bidder's initials & date AS 11/6/14

**BIDDER INFORMATION:**

Company Name: Western Nevada Supply Company  
Federal ID No.: 88-0093037  
Mailing Address: 950 South Rock Blvd.  
City, State, Zip Code: Sparks, NV 89431  
Complete Telephone Number: 775.359.5800  
Complete Fax Number: 775.359.4649

Contact Person/Title: Andrew Siderius waterworks manager  
Mailing Address: 950 South Rock Blvd.  
City, State, Zip Code: Sparks, NV 89431  
Complete Telephone Number: 775.359.5800  
Complete Fax Number: 775.359.4649  
E-mail Address: asiderius@goblueteam.com

Carson City Municipal Code Section 4.04.010 requires that any business operating within Carson City is required to be in possession of a valid Carson City business license. Be advised that upon award of a contract by Carson City, you must either have a current business license or an exemption letter from the Carson City Development Services Department before commencing business. However, possession of said license is not a prerequisite for bidding.

If Bidder has a valid Carson City Business License, please provide number:  
14-00009542

Bidder **does not have** a valid Carson City Business License. Bidder contacted a representative of the Carson City Development Services Department at 775-887-2105 and has been informed that **Bidder does need** a Carson City Business License for this **REQUEST FOR BID**. Bidder certifies that he will obtain a Carson City Business License if awarded this **REQUEST FOR BID**.

Signature \_\_\_\_\_ Date \_\_\_\_\_

Bidder **does not have** a valid Carson City Business License. Bidder certifies that he has spoken to \_\_\_\_\_ a representative of the Carson City Development Services Department at 775-887-2105 and has been informed that **Bidder does not need** a Carson City Business License for this **REQUEST FOR BID**.

Signature \_\_\_\_\_ Date \_\_\_\_\_



**CARSON CITY PURCHASING AND CONTRACTS  
BID RESPONSE**

Bidder's initials & date RB 11/11/14

**DISCLOSURE OF PRINCIPALS:**

**Individual and/or Partnership:**

Owner 1) Name: \_\_\_\_\_  
Address: \_\_\_\_\_  
City, State, Zip Code: \_\_\_\_\_  
Complete Telephone Number: \_\_\_\_\_

Owner 2) Name: \_\_\_\_\_  
Address: \_\_\_\_\_  
City, State, Zip Code: \_\_\_\_\_  
Complete Telephone Number: \_\_\_\_\_

Other 1) Title: \_\_\_\_\_  
Name: \_\_\_\_\_

Other 2) Title: \_\_\_\_\_  
Name: \_\_\_\_\_

**Corporation:**

State in which Company is incorporated: Nevada  
Date Incorporated: February 1964  
Name of Corporation: Western Nevada Supply Co.  
Address: 450 South Fork Blvd.  
City, State, Zip Code: Sparks, NV 89431  
Complete Telephone Number: 775-359-5800

President's Name: Richard J. Revglio

Vice-President's Name: Theodore Revglio

Other 1) Name: \_\_\_\_\_  
Title: \_\_\_\_\_

Other 2) Name: \_\_\_\_\_  
Title: \_\_\_\_\_

# CARSON CITY PURCHASING AND CONTRACTS BID RESPONSE

Bidder's initials & date AS 11/11/14

If Bidder responds NO to any of the following questions, Bidder must use the EXCEPTION SUMMARY document to record any deviations, modifications, and/or alternates proposed to this REQUEST FOR BID. Failure to do so may be justification for rejection of the BID RESPONSE. Bidder must indicate the title of document from the top of the page, the page number from the bottom of the page, the item number corresponding to the item, and a detailed description of the deviation, modification, and/or alternate. Failure to note deviations, modifications, and/or alternates on the EXCEPTION SUMMARY shall be interpreted to convey that Bidder will perform in the manner described and/or specified in this REQUEST FOR BID.

Bidder has read the SPECIFICATIONS and certifies that the product(s) and/or service(s) proposed meets or exceeds the requirements of this **REQUEST FOR BID**.

Yes  No

Bidder has provided "Exhibit A" - Technical Specifications and literature illustrating Bidder's proposed product(s).

Yes  No

Bidder has provided "Exhibit B" - A letter from the manufacturer certifying that Bidder is an authorized representative of the manufacturer for the product(s) being proposed and that any warranty requirements provided for herein will be performed favorably in their behalf.

Yes  No

Bidder agrees that all items will be ordered on an as-needed basis.

Yes  No

Bidder agrees that no guarantee is given that any specific quantities will be ordered.

Yes  No

Bidder agrees that all items bid shall meet the current "Carson City Standard Details for Public Works Construction" in addition to all other standard details listed.

Yes  No

Bidder agrees that all items shall conform to the American Water Works Association standards and all applicable ANSI, ASTM, MSS SP 60 standards.

Yes  No

Bidder has provided "Exhibit C" - A copy of Bidder's warranty, indicating the terms, conditions, and limitations of said warranty.

Yes  No

Bidder agrees that the **CONTRACT TERM** shall be from November 20, 2014 through November 19, 2015.

Yes  No

Bidder agrees that Carson City shall have the right to renew this Contract, for five (5) additional years, subject to negotiation.

Yes  No

Bidder guarantees the pricing through November 19, 2015.

Yes  No

**CARSON CITY PURCHASING AND CONTRACTS  
BID RESPONSE**

Bidder's initials & date AS 11/11/14

Bidder agrees that product(s) supplied pursuant to the provisions of this **REQUEST FOR BID** shall be subject to escalation and/or de-escalation of prices.

Yes  No

Bidder agrees to provide delivery not less than twice each working day Monday through Friday **F.O.B. Carson City Public Works, 3505 Butti Way, Carson City, Nevada C/O Tom Gordon, Warehouse Supply Coordinator** within one (1) working day from date order is placed.

Yes  No

Bidder agrees that all prices shall be **F.O.B. Carson City**. No additional charges for freight, packaging, handling, insurance, etc., shall be allowed. Bidder shall be responsible for all shipping charges for items returned due to error and/or unacceptable condition.

Yes  No

At time of delivery, Bidder agrees to provide a delivery invoice.

Yes  No

Within 48 hours of delivery, Bidder agrees to fax an invoice to Public Works at 775-887-2164 which Carson City will use for the purpose of paying Bidder.

Yes  No

Bidder agrees not mail a duplicate invoice unless specifically requested by Carson City.

Yes  No

Bidder agrees that should he fail to deliver the product(s) and/or perform the service(s) bid in accordance with this **REQUEST FOR BID**, Carson City may declare Bidder in default of contract and recover all damages, costs and fees (including Attorney's fees) allowable by law.

Yes  No

Bidder agrees that in the event of default by Bidder, Carson City may, at its option, pursue one or all of the following alternatives including: procure the product(s) and/or service(s) from another source and hold the defaulting Bidder responsible for an excess cost occasioned thereby, assess a penalty of 5% of the total awarded bid amount, commence with Surety and/or Performance Bond proceedings, debar the defaulting Bidder for not less than one year, or pursue other applicable legal remedies.

Yes  No

Bidder agrees that if necessity requires the use of materials or supplies not conforming to the **SPECIFICATIONS**, they may be accepted and payment shall be made at a proper adjustment in price.

Yes  No

Bidder has read and agrees to abide by the **TERMS AND CONDITIONS** of this **REQUEST FOR BID**.

Yes  No

Bidder has provided "**Exhibit D**" - All addenda must be signed and placed in date and time order.

Yes  No

Bidder has provided "**Exhibit E**" - **BID RESPONSE** additional space on company letterhead.

Yes  No

**CARSON CITY PURCHASING AND CONTRACTS  
BID RESPONSE**

Bidder's initials & date AS 11/1/14

Bidder has provided "Exhibit F"- Supplemental materials.

Yes  No

Bidder agrees that all billings for dates of service prior to July 1 must be submitted to Carson City no later than the first Friday in August of the same year; that a billing submitted after the first Friday in August will subject Bidder to an administrative fee not to exceed \$100.00; and that this amount will be deducted from the stale claim payment due to Bidder.

Yes  No

Bidder has read and agrees to abide by the **INSURANCE REQUIREMENTS** for Commercial General Liability Insurance, Business Automobile Liability Insurance, and Workers' Compensation and Employer's Liability Insurance for this **REQUEST FOR BID**.

Yes  No

Bidder has provided "Exhibit G" - **EXCEPTION SUMMARY** additional space on company letterhead.

Yes  No

Bidder agrees that should he fail to deliver the product(s) and/or perform the service(s) bid in accordance with this **REQUEST FOR BID**, Carson City may declare Bidder in default of contract and recover all damages, costs and fees (including Attorney's fees) allowable by law.

Yes  No

Bidder agrees that in the event of default by Bidder, Carson City may, at its option, pursue one or all of the following alternatives including: procure the product(s) and/or service(s) from another source and hold the defaulting Bidder responsible for an excess cost occasioned thereby, assess a penalty of 5% of the total awarded bid amount, commence with Surety and/or Performance Bond proceedings, debar the defaulting Bidder for not less than one year, or pursue other applicable legal remedies.

Yes  No

Bidder agrees that if necessity requires the use of materials or supplies not conforming to the **SPECIFICATIONS**, they may be accepted and payment shall be made at a proper adjustment in price.

Yes  No

Bidder has read and agrees to abide by the **TERMS AND CONDITIONS** of this **REQUEST FOR BID**.

Yes  No

Bidder has provided "Exhibit D" - All addenda must be signed and placed in date and time order.

Yes  No  Not Applicable

Bidder has provided "Exhibit E" - **BID RESPONSE** additional space on company letterhead.

Yes  No  Not Applicable

Bidder has provided "Exhibit F"- Supplemental materials.

Yes  No  Not Applicable

**CARSON CITY PURCHASING AND CONTRACTS  
BID RESPONSE**

Bidder's initials & date AS 11/11/14

Bidder agrees that all billings for dates of service prior to July 1 must be submitted to Carson City no later than the first Friday in August of the same year; that a billing submitted after the first Friday in August will subject Bidder to an administrative fee not to exceed \$100.00; and that this amount will be deducted from the stale claim payment due to Bidder.

Yes No

Bidder has read and agrees to abide by the **INSURANCE REQUIREMENTS** for Commercial General Liability Insurance, Business Automobile Liability Insurance, Professional Liability Insurance, and Workers' Compensation and Employer's Liability Insurance for this **REQUEST FOR BID**.

Yes No

Bidder has provided "Exhibit G" - **EXCEPTION SUMMARY** additional space on company letterhead.

Yes No **Not Applicable**

**MASTERCARD ACCEPTANCE.** Bidder agrees to accept MasterCard as a form of payment under this Contract at no additional cost to Carson City.

Yes **No**

**CASH DISCOUNT** of 1 % may be taken in addition to the price(s) stated for the terms of 15 calendar days. Prompt payment discounts will be considered in award recommendation only if discount period is fifteen (15) or more calendar days. Discount period will be computed from the date Carson City acknowledges that the delivery and/or performance meets the requirements of this **REQUEST FOR BID** or from the date the correct invoice is received by the appropriate Carson City department/division accounts payable clerk, whichever is the latter date. Payment is deemed to be made on the date payment is mailed to Bidder.

Bidder agrees that if cash discount is provided that Bidder shall indicate the discount prices on each invoice.

Yes **No**



**CARSON CITY PURCHASING AND CONTRACTS  
BID RESPONSE**

Bidder's initials & date AS 11/11/14

**EXCEPTION SUMMARY INSTRUCTIONS:**

Use this document to record any deviations, modifications, and/or alternates proposed to this **REQUEST FOR BID**. Failure to do so may be justification for rejection of the **BID RESPONSE**. Bidder must indicate the line number corresponding to the item and a detailed description of the deviation, modification, and/or alternate. Failure to note deviations, modifications, and/or alternates on the **EXCEPTION SUMMARY** shall be interpreted to convey that Bidder will perform in the manner described and/or specified in this **REQUEST FOR BID**.

If additional space is required, use company letterhead and mark as "Exhibit G".

If there are no deviations, modifications, and/or alternates proposed to this **REQUEST FOR BID**, write "None".

⊕ Credit Cards will not be an approved form of payment.

⊕ Cash Discount offered will not be reflected in invoice pricing. Discount to be taken at time of payment + reconciled with remittance slip.

**\*\*\* END OF BID RESPONSE \*\*\***



[www.goblue team.com](http://www.goblue team.com)

AS  
11/11/14

November 11, 2014

Re: Carson City Purchasing and Contracts  
Request for bid #1415-092

Exhibit A: Technical Specifications

Each individual product has its own specification sheet. The documents provided are a sample of the products offered from the manufacturers that have been represented in our bid. All items bid are to meet or exceed Carson City's standards. Individual specifications are available upon request.

Sincerely

Andrew Siderius  
Waterworks Division Manager



12/11/14

BULLETIN 600  
FEBRUARY 2014



## APCO CLEAN WATER AIR RELEASE VALVES

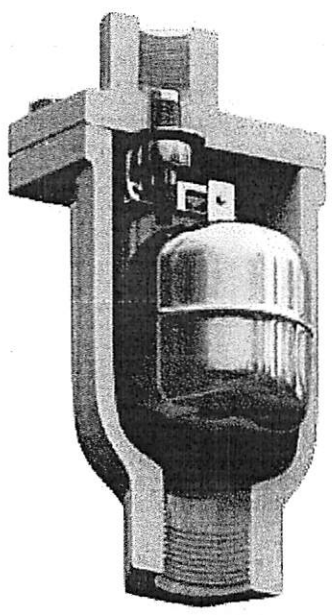

Model 50

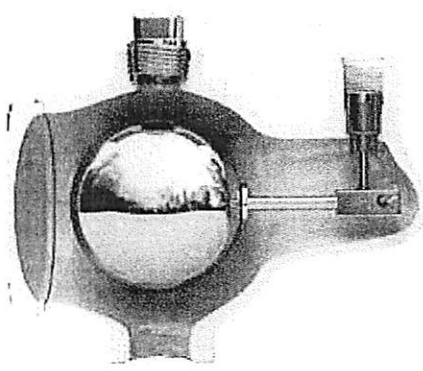

Model 55

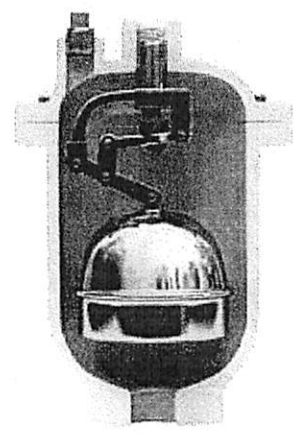

Model 200A

AS  
2/11/14

# Air Release Valves

## Why and Where to Use

An Air Release Valve has a small venting orifice and is used wherever air is entrained in water under pressure. These pockets of air increase the resistance to the flow of water. In critical installations, air can reduce the capacity of a line down to zero. More common is an increased resistance of 10 to 15%. The increased resistance must be overcome by the pump using more power than necessary to move the required amount of water. Such a loss can continue unnoticed for years creating excessive power consumption costs. This is a major reason why all points where air can collect should be equipped with an APCO Air Release Valve.

## How to Operate

These valves have much smaller orifices than the Air/Vacuum Valves. Their function is to release small pockets of air which gather at the high points of a system after it is filled and under pressure. The Air Release Valve has the ability to open against internal pressure because it has a small orifice and a leverage mechanism which multiplies the force of the float. This force must be greater than the internal pressure across the orifice in order to open it when a pocket of air needs to be vented. This explains why, as the internal pressure increases, the orifice decreases in size to facilitate the valve opening.

## Simple Lever

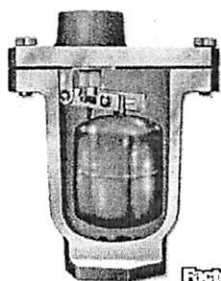

**#50**

.5, .75, 1" (15, 20, 25 mm) Inlet

### Physical Dimensions

Height - 5.875" (149 mm)

Width - 3.75" (95 mm)

Weight - 6 lbs (3 kg)

Standard pressures up to 175 psi (1207 kpa) and up to 300 psi (2068 kpa) with special orifice.

Specify if operating pressure is below 20 psi (138 kpa).

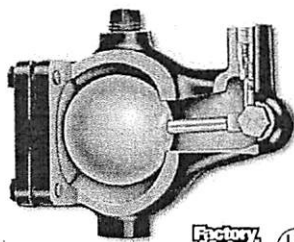

**#55**

.5" (15 mm) Inlet

### Physical Dimensions

Height - 5" (127 mm)

Length - 6.375" (162 mm)

Width - 3.313" (84 mm)

Weight - 5.5 lbs (2.5 kg)

Standard pressures up to 175 psi (1207 kpa).

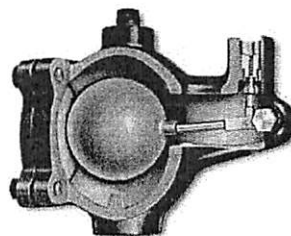

**#65**

.75" (20mm) Inlet

### Physical Dimensions

Height - 7" (178 mm)

Length - 8.5" (216 mm)

Width - 4.5" (114 mm)

Weight - 9 lbs (4 kg)

Standard pressures up to 150 psi (1034 kpa).

All APCO Air Release Valves are 100% Hydrostatically factory tested to ANSI/AWWA C512 standards.

## APCO Uses Stainless Steel Floats Exclusively

Examine these quality features provided at no extra cost:

1. ASTM quality materials guaranteed throughout
2. Stainless steel floats
3. Conserve pumping power – eliminate restricted high points
4. Create maximum pipeline efficiency

## Materials of Construction

Body and Cover - Cast Iron or Ductile Iron

Float - Stainless Steel

Seat - Bronze-Stainless or Buna-N

Needle - Bronze or Stainless Steel

Linkage - Delrin, Bronze or Stainless Steel

Other internal parts – Lever Pins, Retaining Rings, and Screws are Stainless Steel or Bronze.

**Note:** Great care is taken in the choice of materials to avoid galvanic action. Bronze components meet current lead-free requirements

AS  
11/14/14

## Where to Install

Typical pipeline and position of necessary APCO air valves

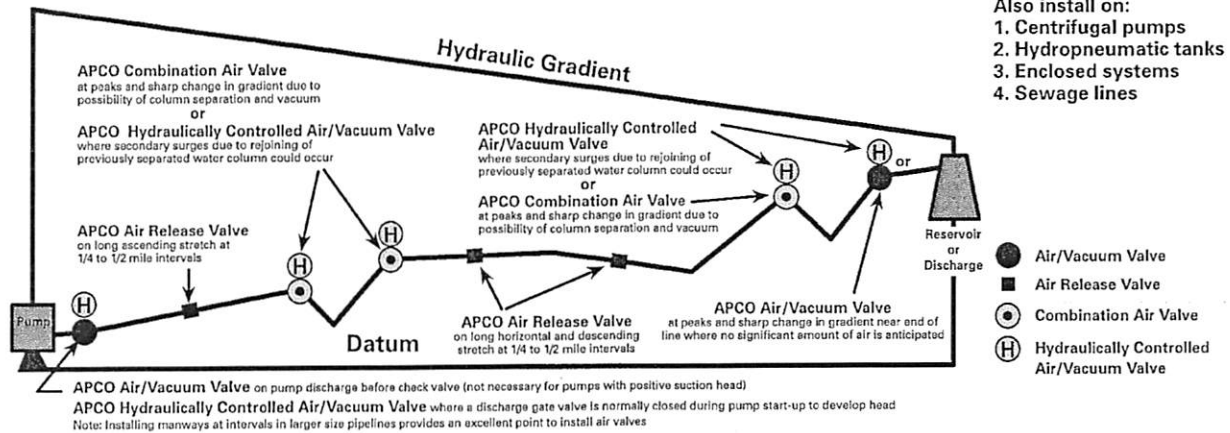

- Also install on:
1. Centrifugal pumps
  2. Hydropneumatic tanks
  3. Enclosed systems
  4. Sewage lines

## Compound Lever

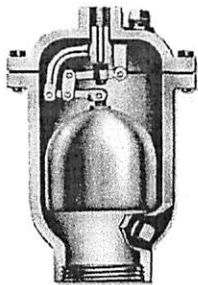

### #200A

1", 2" (25, 50 mm) Inlet

#### Physical Dimensions

Height - 10" (254 mm)

Width - 7" (179 mm)

Weight - 20 lbs (9 kg)

Inlet - 1" or 2"

(25, 51mm)  
pipe thread

Standard pressures up to 150 psi (1034 kpa) and up to 300 psi (2068 kpa) or higher with special orifice.

Concave float is patented.

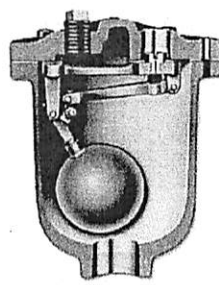

### #200

2" (50 mm) Inlet

#### Physical Dimensions

Height - 12.5" (318 mm)

Width - 9.5" (241 mm)

Weight - 45 lbs (20 kg)

Inlet - 2" (51mm)  
pipe thread

Standard pressures up to 150 psi (1034 kpa) and up to 300 psi (2068 kpa) or higher with special orifice.

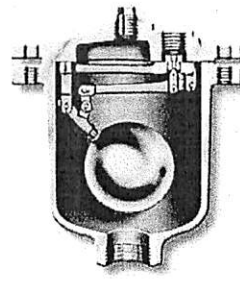

### #205

2" (50 mm) Inlet

#### Physical Dimensions

Height - 13" (330 mm)

Width - 12" (305 mm)

Weight - 75 lbs (34 kg)

Inlet - 2" (51mm)  
pipe thread

Flanged inlet available 150 or 300 lb. class

Standard pressures up to 500 psi (3447 kpa) and up to 1500 psi (10342 kpa) with special orifice.

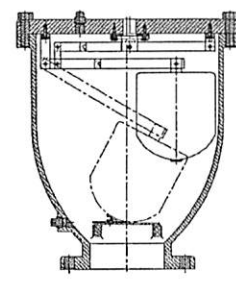

### #207

6" (150 mm) Inlet

#### Physical Dimensions

Height - 28" (711 mm)

Width - 13.5" (343 mm)

Weight - 200 lbs (91 kg)

Inlet - 6" (152 mm)  
125# flange

Discharge orifice - 1" (25mm) diameter

HIGH VENTING CAPACITY  
Standard pressures up to 150 psi (1034 kpa) and up to 300 psi (2068 kpa) with special orifice.

Higher pressure classes available.

For selection and sizing of all the above air valves, see the Venting Capacity Graph for Air Release Valves on the back page of this bulletin or ask for APCO Air Valve Sizing Software.

Manufactured to AWWA C-512

ISO connections available



AS  
11/11/14

July 2012

For the most current product/pricing information on Anvil products, please visit our website at [www.anvilintl.com](http://www.anvilintl.com).

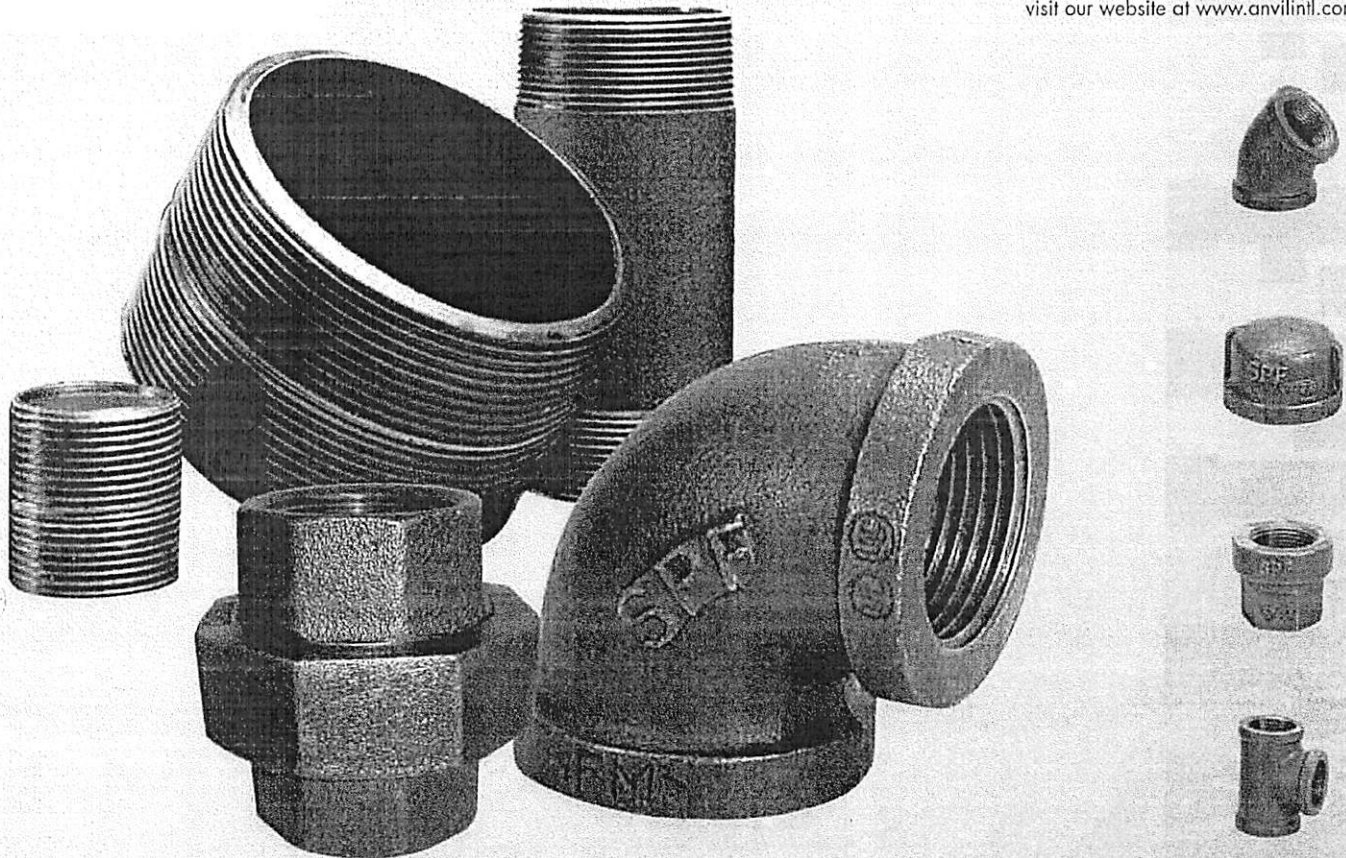

# Steel Pipe Nipples & Malleable Fittings

BUILDING CONNECTIONS THAT LAST



AS 11/11/14



Utility Pipe Fittings and Accessories

# Compact MJ Fittings

ANSI/AWWA C153/A21.53

## 2" - 64" DUCTILE IRON MECHANICAL JOINT COMPACT FITTINGS

GENERAL SPECIFICATIONS

- MATERIAL:** Ductile Iron per ASTM A536
- PRESSURE:** 350 PSI rating for 2" - 24" sizes, 250 PSI rating for 30" - 48" sizes and 150 PSI rating for 54" - 64" sizes
- TESTING:** In accordance with ANSI/AWWA C153/A21.53 and UL requirements
- LAYING LENGTH:** In accordance with ANSI/AWWA C153/A21.53 (fittings not listed in ANSI/AWWA have dimensions per Star design as noted in the catalog)
- DEFLECTION:** 2"-4"=8° | 6"=7° | 8"-12"=5° | 14"-16"=3 1/2° | 18"-24"=3° | 30"-48"=2°
- WEIGHTS:** Are in pounds, unless noted otherwise and do not include accessories, cement lining and coating
- FLANGES:** Flanged ends on fittings match ANSI/AWWA C115/A21.15 and ANSI B16.1 class 125 flanges
- CEMENT LINING:** In accordance with ANSI/AWWA C104/A21.4 -- size 2" - 3" single thickness and sizes 4" - 64" double thickness
- COATING:** Asphaltic seal coat inside and out in accordance with ANSI/AWWA C104/A21.4 and referenced in ANSI/AWWA C153/A21.53
- GASKETS:** SBR in accordance with ANSI/AWWA C111/A21.11 (see pg. 16)
- T-BOLTS/NUTS:** Low alloy steel in accordance with ANSI/AWWA C111/A21.11 (see pg. 18)
- APPROVALS:** 3" - 12" UL/ULC Listed | 2" and greater are UL/ANSI/NSF Standards 61 and 372 | 3" - 16" FM APPROVED. Please consult factory for detail listing and approvals.
- DIMENSIONS:** All dimensions are in inches unless noted otherwise.
- INSTALLATION:** Per ANSI/AWWA C600 and C111 using DIP conforming to C150/C151 and PVC pipe conforming to C900/C905

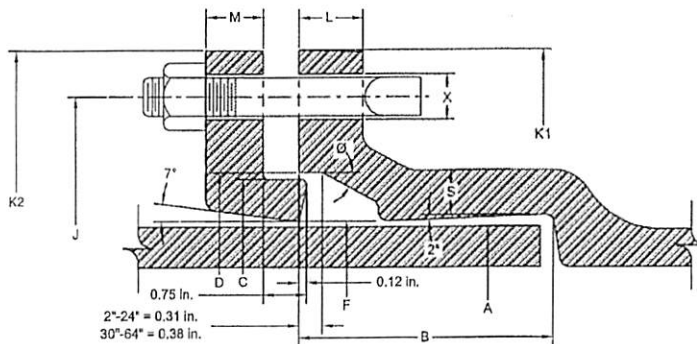

MECHANICAL JOINT DIMENSIONS																
NOM. SIZE	A DIA.	B	C DIA.	D DIA.	F DIA.	J DIA.	K1 DIA.	K2 DIA.	L	M	S	Ø	X DIA.	BOLTS		
														SIZE	NO.	
2	2.50	2.50	3.39	3.50	2.61	4.75	6.19	6.25	0.58	0.62	0.36	28°	3/4	3/8 x 3	2	
3	3.96	2.50	4.84	4.94	4.06	6.19	7.62	7.69	0.58	0.62	0.39	28°	3/4	3/8 x 3	4	
4	4.80	2.50	5.92	6.02	4.90	7.50	9.06	9.12	0.60	0.75	0.39	28°	7/8	3/4 x 3 1/2	4	
6	6.90	2.50	8.02	8.12	7.00	9.50	11.06	11.12	0.63	0.88	0.43	28°	7/8	3/4 x 3 1/2	6	
8	9.05	2.50	10.17	10.27	9.15	11.75	13.31	13.37	0.66	1.00	0.45	28°	7/8	3/4 x 3 1/2	6	
10	11.10	2.50	12.22	12.34	11.20	14.00	15.62	15.62	0.70	1.00	0.47	28°	7/8	3/4 x 3 1/2	8	
12	13.20	2.50	14.32	14.44	13.30	16.25	17.88	17.88	0.73	1.00	0.49	28°	7/8	3/4 x 3 1/2	8	
14	15.30	3.50	16.40	16.54	15.44	18.75	20.25	20.25	0.79	1.25	0.55	28°	7/8	3/4 x 4	10	
16	17.40	3.50	18.50	18.64	17.54	21.00	22.50	22.50	0.85	1.31	0.58	28°	7/8	3/4 x 4	12	
18	19.50	3.50	20.60	20.74	19.64	23.25	24.83	24.75	1.00	1.38	0.68	28°	7/8	3/4 x 4	12	
20	21.60	3.50	22.70	22.84	21.74	25.50	27.08	27.00	1.02	1.44	0.69	28°	7/8	3/4 x 4	14	
24	25.80	3.50	26.90	27.04	25.94	30.00	31.58	31.50	1.02	1.56	0.75	28°	7/8	3/4 x 4 1/2	16	
30	32.00	4.00	33.29	33.46	32.17	36.88	39.12	39.12	1.31	2.00	0.82	20°	1 1/8	1 x 5 1/2	20	
36	38.30	4.00	39.59	39.76	38.47	43.75	46.00	46.00	1.45	2.00	1.00	20°	1 1/8	1 x 5 1/2	24	
42	44.50	4.00	45.79	45.96	44.67	50.62	53.12	53.12	1.45	2.00	1.25	20°	1 3/8	1 1/4 x 6	28	
48	50.80	4.00	52.09	52.26	50.97	57.50	60.00	60.00	1.45	2.00	1.35	20°	1 3/8	1 1/4 x 6	32	
54	{Fittings & Dimensions Available On Request }															
60																
64																

STAR PIPE PRODUCTS



UCAT:14.02  
\*REGISTERED TRADEMARK OF STAR PIPE PRODUCTS

STAR PIPE PRODUCTS  
HOUSTON CORPORATE | TOLL FREE 1-800-999-3009 | FAX 281-558-9000  
www.starpipeproducts.com

KS 11/11/14

CATALOG C-BV-0812

# NIBCO®

AHEAD OF THE FLOW®

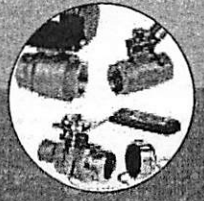
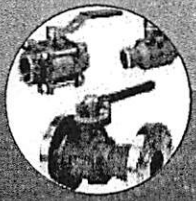
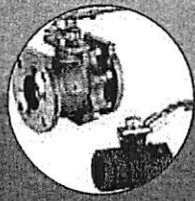
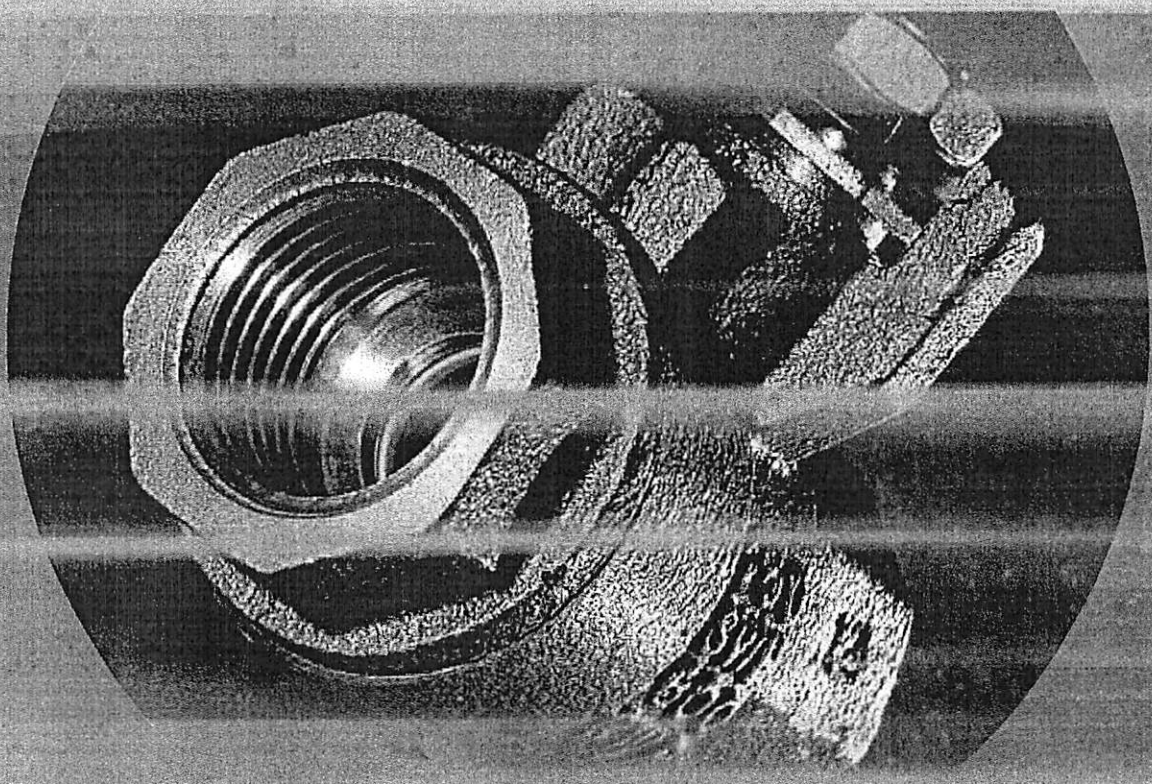

Ball Valves



**Figure # 206**  
Bronze Threaded Gate Valve

AB  
11/11/14

**Product Features**

- 125# WSP / 200# WOG
- Bronze Body
- Solid Disc
- Threaded Ends
- Screw Over Bonnet - Sizes 1/4" - 2"
- Inserted Bonnet - Sizes 2-1/2" - 4"
- Non-Rising Stem
- NSF to 2"



**Materials & Specifications**

Item	Description	Material	Specification
1	Body	Cast Bronze	B62-C83600
2	Bonnet	Cast Bronze	B62-C83600
3	Stem	Brass	DR Alloy
4	Disc	Cast Bronze	B62-C83600
5	Lock Nut	Brass	DR Alloy
6	Packing Nut	Size 4" Bronze	B62-C83600
6	Packing Nut	Sizes 3/8" -3" Brass	B283-C37700
7	Gland	Brass	B124-C37700
8	Gland Packing	Plastic /Graphite	T#2996NA
9	Handwheel	Sizes 1" - 4"	B85-SC114A
9	Handwheel	Sizes 3/8" - 3/4"	B86-AG40A
10	Wheel Nut	Zinc plated Steel	A36
11	Name Plate	Aluminum	B209-1100

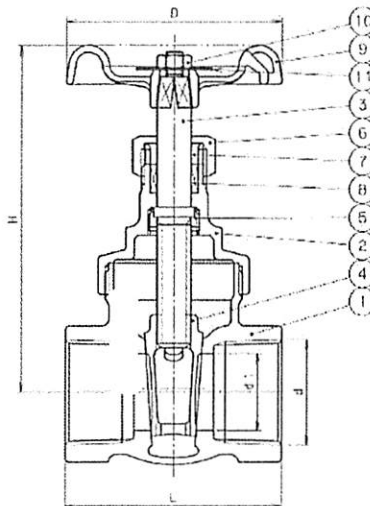

**Dimensions, Weights (inches-lbs.) & Valve Data**

Size	1/4	3/8	1/2	3/4	1	1-1/4	1-1/2	2	2-1/2	3	4
D	1.89	1.89	1.89	2.17	2.48	2.76	3.15	3.54	3.94	4.92	6.30
d1	.39	.39	.51	.71	.95	1.22	1.46	1.93	2.44	2.95	3.94
H	3.03	3.03	3.19	3.70	4.25	4.92	5.43	6.65	8.07	9.57	12.24
L	1.65	1.65	1.73	1.93	2.21	2.40	2.60	2.87	3.54	3.94	5.51
S	.95	.95	1.08	1.32	1.61	1.97	2.24	2.76	3.39	3.94	5.12
Cv	2.8	5.7	10.8	20	35	65	118	195	330	460	772
Wt.- lbs.	.57	.55	.64	.88	1.28	1.81	2.51	3.95	6.86	10.14	24.69

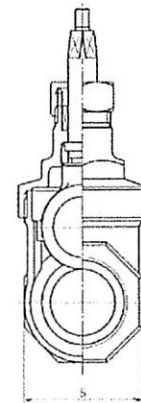

SIZES 2 1/2 to 4



\* 11/14

# • *Products of Merit*

STAINLESS

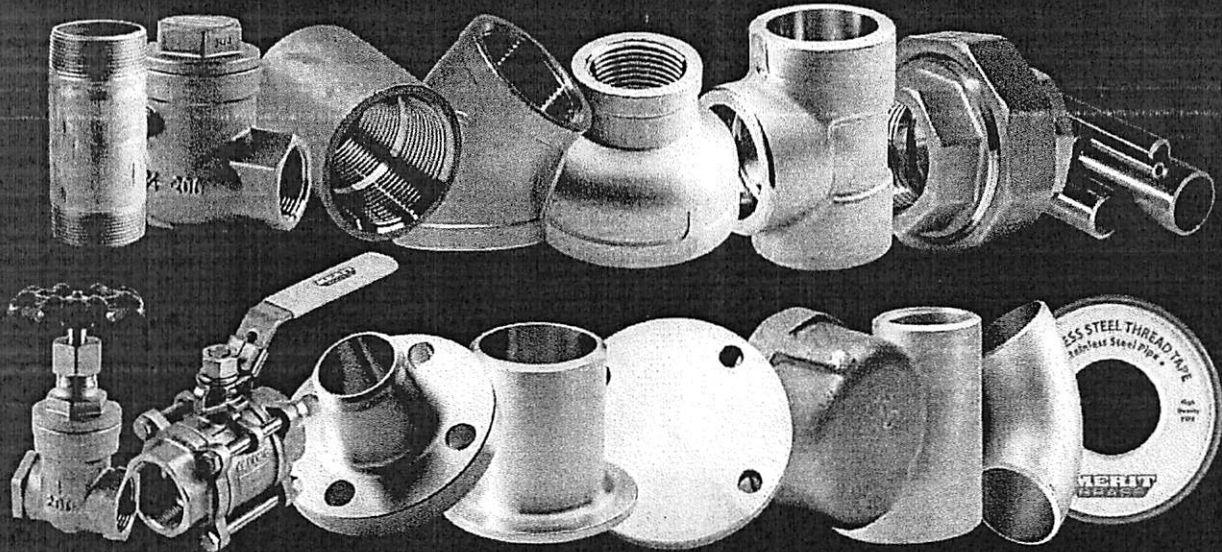

A105-N FORGED CARBON STEEL

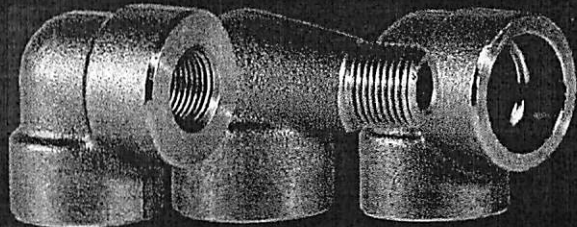

# MERIT BRASS

BRASS

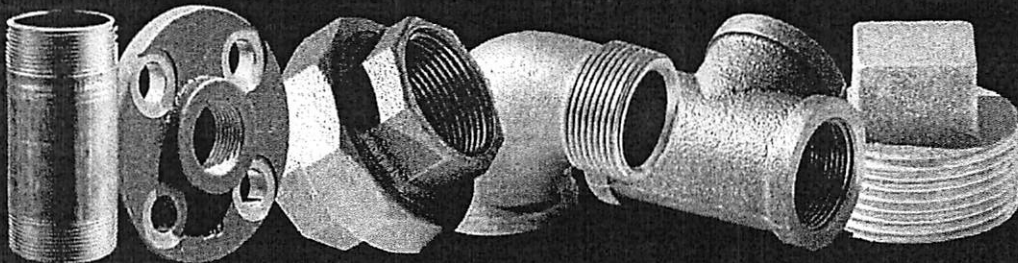

CHROME

ALUMINUM

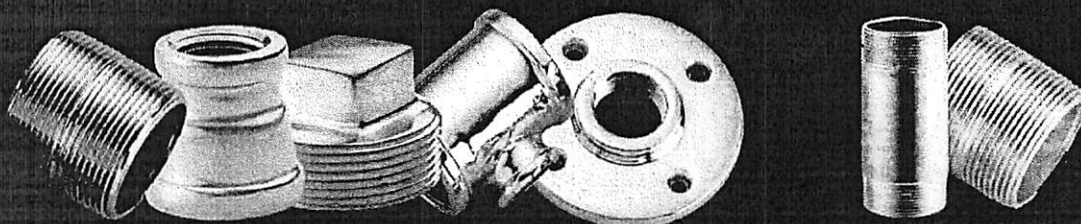



AB  
11/11/14

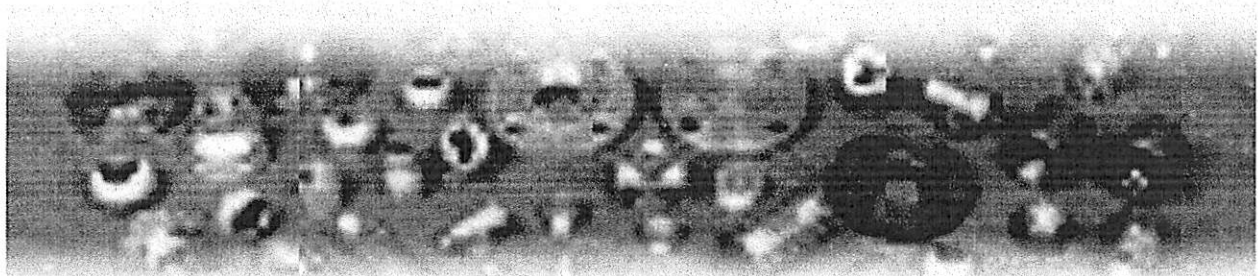

**NIPPLES**

<i>Red Brass (Standard/Extra Heavy) ASTM B687</i>	1/8" - 6"
<i>Chrome Plated Red Brass ASTM B687</i>	1/8" - 6"
<i>Stainless Steel (304/L &amp; 316/L) ASTM A733</i>	
Schedule 40 Welded	1/8" - 8"
Schedule 40 & 80 Seamless	1/8" - 3"
<i>Aluminum (6061-40)</i>	1/8" - 4"

**PIPE**

<i>Red Brass ASTM B43</i>	
Standard H58 Hard Temper	1/8" - 6"
Standard 061 Annealed Temper	1/8" - 4"
Extra Heavy H58 Hard Temper	1/8" - 4"
Chrome Plated H58 Hard Temper	1/4" - 4"
<i>Stainless Steel (304/L &amp; 316/L) ASTM A312/SA312</i>	
Welded Schedule 10	1/2" - 12"
Welded Schedule 40	1/8" - 12"
Seamless Schedule 40	1/8" - 4"
Seamless Schedule 80	1/8" - 4"
<i>Aluminum ASTM B241 (6061-T6)</i>	
Standard	1/8" - 6"

**TUBING**

<i>Stainless Steel (304/L &amp; 316/L) (.035, .049, .065, .095 Walls)</i>	
Seamless (ASTM A213/A269)	1/4" - 1"
Welded (ASTM A249/A269)	1/4" - 1"

**SYPHONS**

<i>Brass</i>	1/4"
<i>Stainless Steel (304/L &amp; 316/L)</i>	1/4"

**STAINLESS STEEL PTFE THREAD TAPE**

1/2" & 3/4"

**VALVES**

<i>Stainless Steel Ball (316)</i>	
One Piece 800 WOG ("V" Series)	1/4" - 2"
One Piece 1000 WOG ("K" Series)	1/4" - 2"
Two Piece 2000/1500 WOG ("V" Series)	1/4" - 2"
Two Piece Full Port 1000 WOG ("V" & "K" Series)	1/4" - 3"
Two Piece Full Port 150# & 300# Flanged End ("K" Series)	1/2" - 6"
Three Piece Full Port 1000 WOG ("V" & "K" Series)	
Threaded	1/4" - 3"
Socket Weld	1/2" - 3"
Stainless Steel (316) Swing Check Class 200 ("V" Series)	1/4" - 3"
Stainless Steel (316) Gate Class 200 ("V" Series)	1/2" - 2"

**FITTINGS**

<i>Brass Threaded ASTM B584 - Leaded &amp; Lead-Free</i>	
Domestic (125LB & 250LB)	1/8" - 6"
Import (125LB & 250LB)	1/8" - 4"
Chrome Plated (125LB)	1/8" - 2"
<i>Brass Barstock</i>	
Domestic (125LB) - Leaded & Lead-Free	1/8" - 3/4"
<i>Stainless Steel (304 &amp; 316)</i>	
Cast 150LB (Standard) (AISI 304 & 316)	1/8" - 4"
Cast 150LB MSS SP-114	
Threaded	1/8" - 4"
Socket Weld	1/2" - 2"
Barstock 1000LB ASTM A182 or A479	1/8" - 3"
3000LB (Threaded & Socket Weld) ASTM A182*	1/8" - 2"
Buttweld (Schedules 10 & 40) ASTM A403*	1/2" - 12"
MSS Type A & C Stub Ends ASTM A403*	
Schedule 10	1/2" - 12"
Schedule 40 (Type A Only)	1/2" - 8"
<i>Carbon Steel Forged A105-N</i>	
2000LB Threaded	1/4" - 2"
3000LB Threaded	1/8" - 3"
3000LB Socket Weld	1/2" - 3"

**OUTLETS**

<i>Stainless Steel (304/L &amp; 316/L)</i>	
Threaded	1/8" - 4"
Socket Weld	1/2" - 4"
Buttweld (Schedule 40)	1/2" - 4"
<i>Carbon Steel</i>	
Threaded	1/2" - 4"
Socket Weld	1/2" - 4"
Buttweld (Schedule 40)	1/2" - 4"

**FLANGES**

<i>Brass</i>	
Companion (Threaded) (150LB & 300LB) ASTM B584	1/2" - 6"
<i>Stainless Steel</i>	
ANSI 150LB & 300LB (304/L & 316/L) ASTM A182	1/2" - 12"
MSS 150LB (304 & 316) ASTM A351	1/2" - 10"
Plate (304/L & 316/L 150#)	
Tube OD Slip On	1-1/2" - 12"
Blind	1" - 12"
IPS Slip On	1" - 12"
Ductile Iron Backup ASTM A536 & Galvanized	1/2" - 12"

**SPECIALS FABRICATION**

*Thread Capabilities:*

- NPT National Pipe Taper
- NPTF National Pipe Taper Fuel & Oil
- NPSL National Pipe Straight Locknut
- NPSM National Pipe Straight Mechanical
- NPSH National Pipe Straight Hose

*Manufacturing Capabilities:*

- Plain Roller Cut
- Plain Square Cut
- Plain Ream & Chamfer
- Victaulic Groove (Roll or Cut)
- Per Print O.D. & I.D. Machining
- Per Print Bending (1/8" - 1" Diameter)

\* Available in 304/L and 316/L

All dimensions and specifications are subject to customary manufacturing variations for goods of similar quality. Merit Brass assumes no responsibility for deviations from specifications.

AS 11/14

**FORD**

# Ford Products

11/2013



**Corporation Stops**  
Catalog Section A

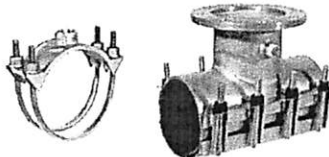

**Service Saddles and Tapping Sleeves**  
Catalog Section AA

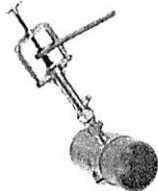

**Drilling Machine**  
Catalog Section AB



**Inside Meter Settings**  
Catalog Section B



**Meter Boxes**  
Catalog Section C



**Meter Box Covers**  
Catalog Section D



**Meter Yokes**  
Catalog Section E

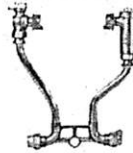

**Coppersetters, Linesetters & Resetters**  
Catalog Section F



**Plastic Pit Setters**  
Catalog Section FA

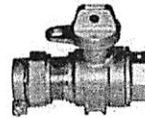

**Valves and Branch Valve Assemblies**  
Catalog Section G



**Curb Boxes**  
Catalog Section GA



**Meter Couplings, Adapters, Idlers & Other Accessories**  
Catalog Section H



**Check Valves and Retrosetters**  
Catalog Section I



**Couplings for Service Line Pipe and Tubing**  
Catalog Section J

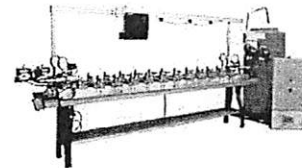

**Water Meter Testing Equipment**  
Catalog Section K



**Pipe Repair Products**  
Catalog Section L

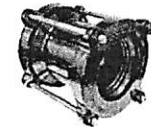

**Bolted Flex Couplings**  
Catalog Section M



**Fabricated Steel Products**  
Catalog Section N



**Uni-Flange® Adapter Flanges and Restraints for PVC and Ductile Iron Pipe**  
Catalog Section U



The Ford Meter Box Co., Inc. 775 Manchester Avenue, P.O. Box 443, Wabash, Indiana, USA 46992-0443  
Telephone: 260-563-3171 FAX: 800-826-3487 Overseas FAX: 260-563-0167 <http://www.fordmeterbox.com>

FFP

MS  
11/11/14

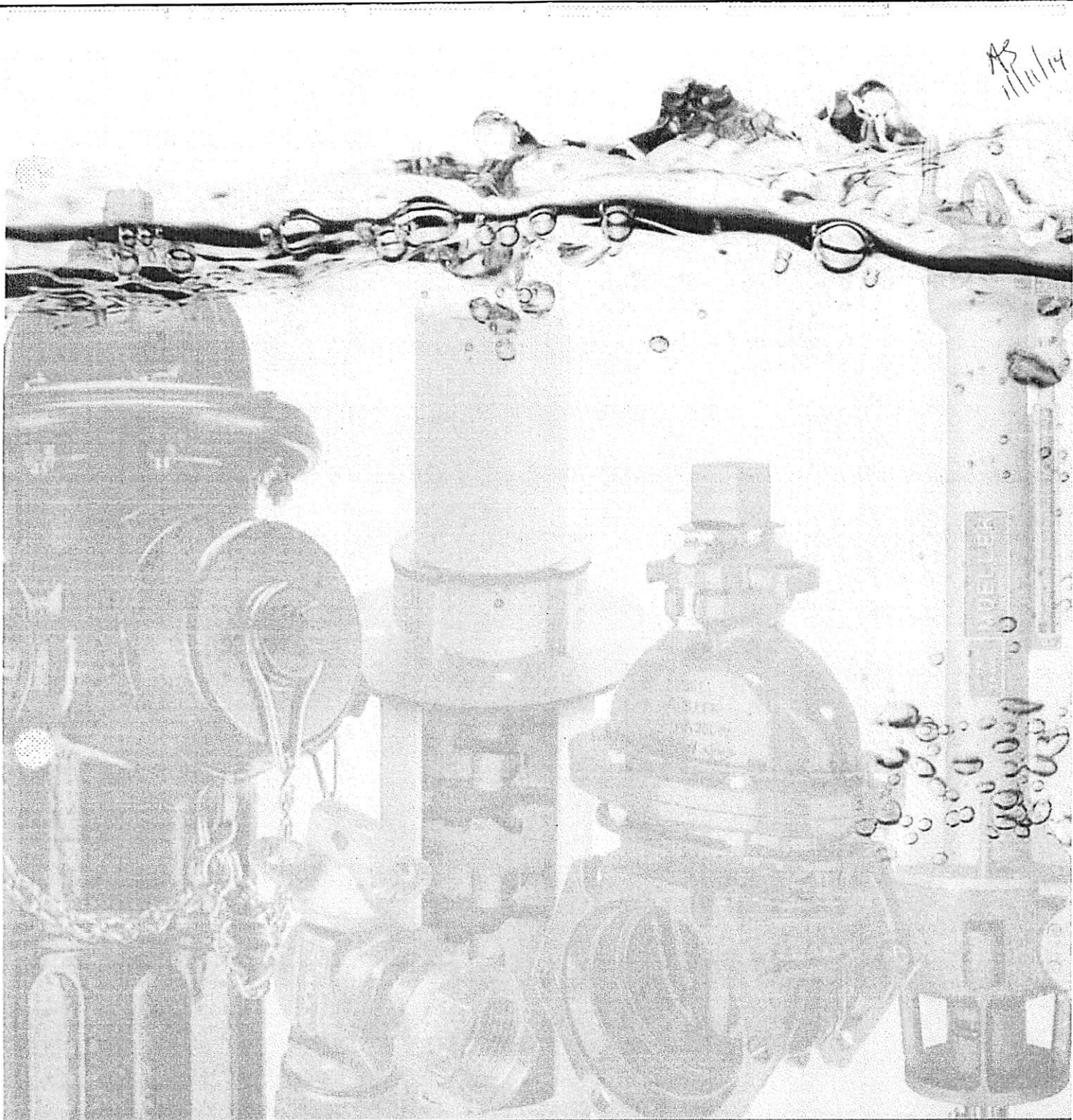

# Water Distribution Products

Full-line product offering

**Mueller Co.**

AS  
11/14/14

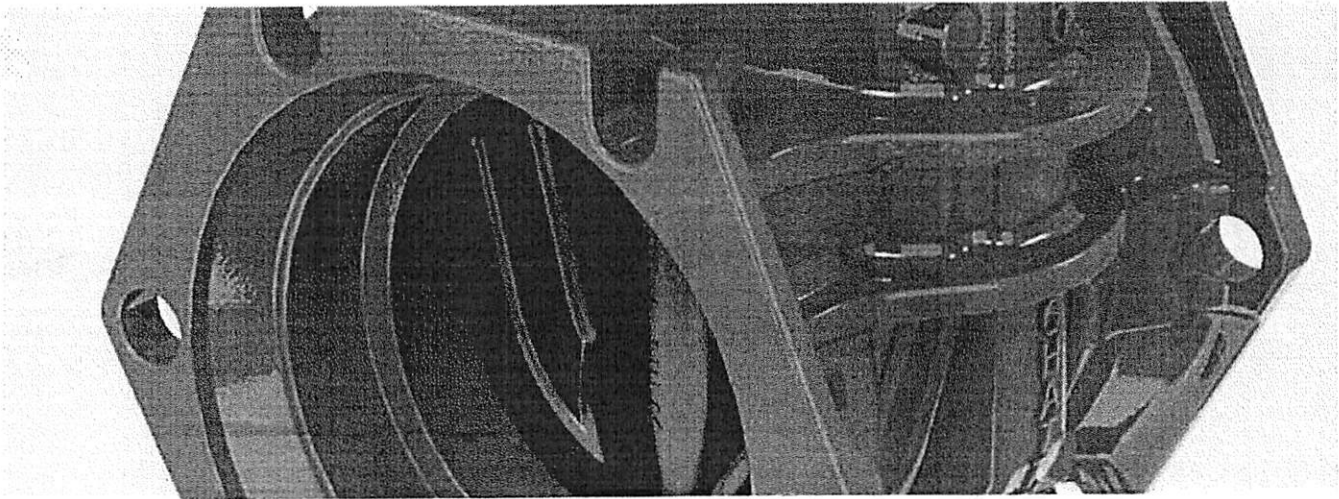

## Mueller Valves

Resilient Wedge Gate Valves from Mueller® feature a forged bronze stem (through 12") and thrust collar for superior strength, an elastomer-encapsulated ductile iron wedge and engineered plastic guides to stabilize the wedge and prevent binding. Sizes: 2" to 54" with working pressures to 350 psig (2400 kPa/24 Barg). Connection options include: mechanical joint (MJ), flanged (FL), slip-on (SL), radial compression (RAD), and threaded (THD). Double disc gate valves are also available.



350psi Ductile Iron  
Resilient Wedge Gate Valve  
(Available 4" - 12")

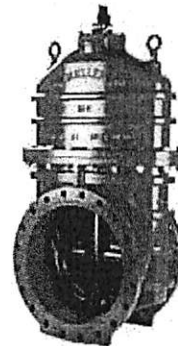

175-250 psi Ductile Iron  
Resilient Wedge Gate Valve  
(Available 14" - 54")

## Henry Pratt® Valves

Mueller supplies top-performing butterfly valves and a variety of check valves. Lineseal® butterfly valves are available in either ductile iron or cast iron. Butterfly valves open with less torque required, lowering the cost of actuation. Sizes: 3" to 48" with working pressures to 250 psig (1725 kPa/17 Barg). Connection options include flanged, slip-on, and MJ. Mueller offers a variety of check valves including, gravity swing, weight and spring-assisted lever, and a flexible disc style. All check valves feature internal parts that are easily accessible through valve top, so the valve does not have to be removed from the line for maintenance. Sizes: 2" to 36" and working pressures to 250 psig (1725 kPa/17 Barg).



Butterfly Valve

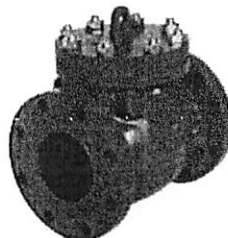

Check Valve

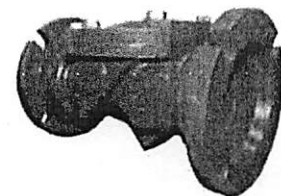

Flex Check Valve

AS  
1/1/14

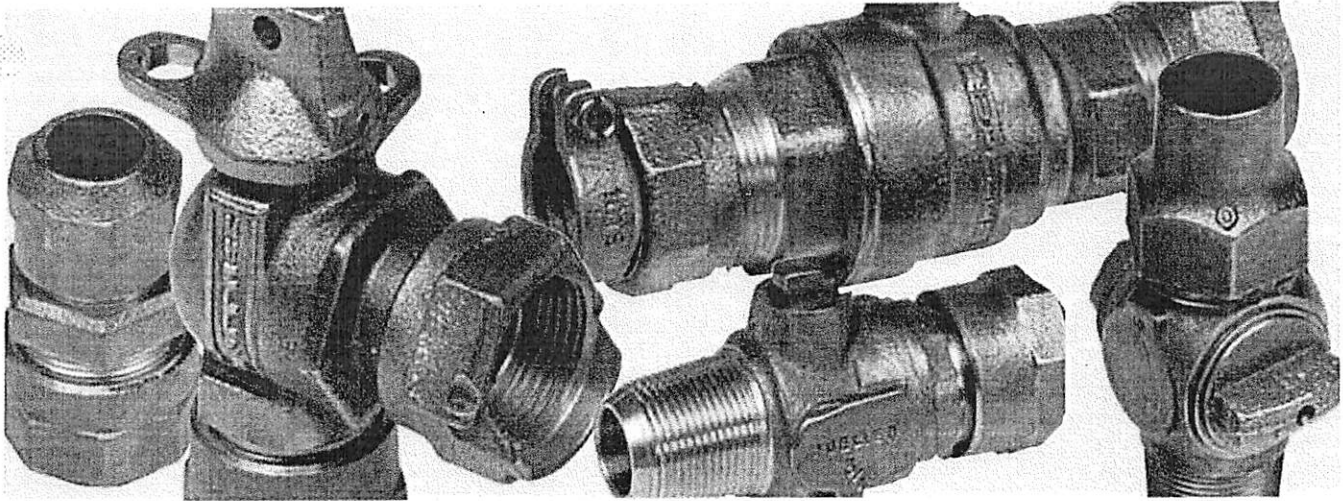

## Service Brass

### Corporation Valves

Corporation valves from Mueller Co. are available for virtually any service line installation. Products feature durable, low-lead brass construction and a wide variety of outlet connection choices. Valve types include ball, plug, and ground key styles. Sizes: 1/2" to 2" with working pressures to 300 psig (2075 kPa/20 Barg).

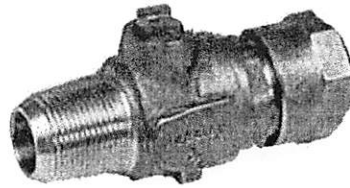

Corporation Valve

### Curb Valves and Boxes

Curb valves & boxes from Mueller Co. feature an extensive line of products and a full range of box accessories, including shut-off rods, augers and keys. Curb valve styles include Mueller 300™ ball valves, Oriseal® plug and ground key types.

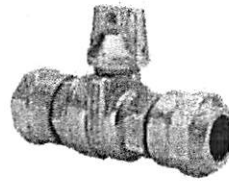

Ball Curb Valve



Curb Box

### Pipe Fittings

Service fittings from Mueller Co. are duty-proven and available in styles to fit today's popular types of water service pipe and tubing. Products feature durable main body brass construction, assuring pressure-tight connections. Types include Mueller 110® and other compression connections, Insta-Tite® stab-in, copper flare, threaded and other specialty connections. There's a style for virtually any application.



Mueller Grip Compression Connection



Mueller 110® Compression Connection



PackJoint Connection



INSTA-TITE® Connection

AS 11/1/14

# **ROMAC** **INDUSTRIES, INC.**

Quality & Innovation, Manufactured in the U.S.A.

Repair Clamps • Couplings • Expansion Joints • Pipe Restraint • Service Saddles  
Dismantling Joints • Tapping Sleeves • Tapping Machines  
HDPE Pipe Products • Line-Stop & Valve Insertion • Waterworks Tools



1.800.426.9341 • [www.romac.com](http://www.romac.com)

AS 1/14/19



Romac founder Manford 'Mac' McNeil.

### BEGINNINGS

In 1969 Manford 'Mac' McNeil started Romac with two employees in a small warehouse in Bellevue, WA - a suburb of Seattle. It was then that Mac introduced the first all stainless steel repair clamp.

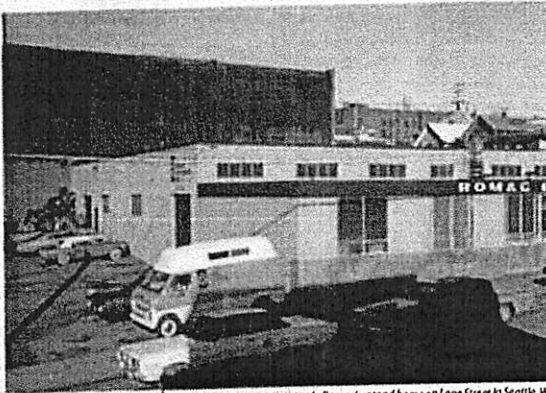

1974 - Romac's second home on Lane Street in Seattle, WA.

Armed with a great product and propelled by a commitment to providing customers with **first-rate customer service** and **lightning fast product delivery**, Romac experienced remarkable growth.

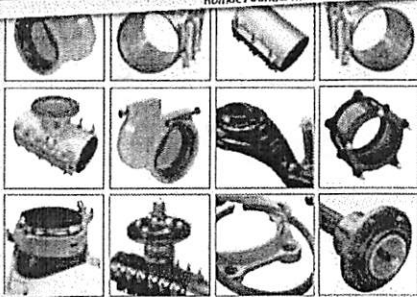

### ROMAC ORIGINALS

In the following years Romac pushed to develop new ideas into inventive products that no one in the industry had seen.

- Color-coded ductile iron couplings.
- Nylon coated service saddles.
- Two-bolt ductile iron couplings.
- All stainless steel tapping sleeves.

Many of these new "better-way" products are now industry standards.

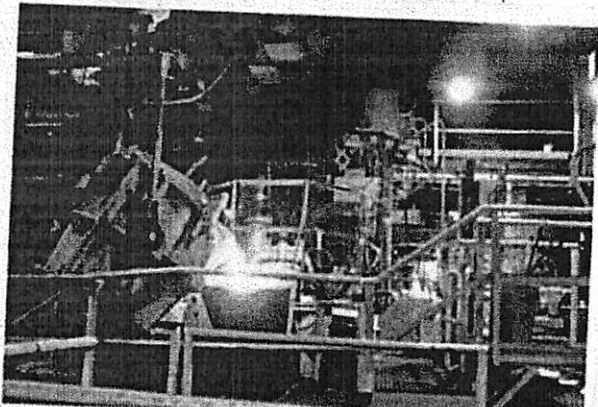

Autospout in Romac's Foundry, Sultan WA (40 miles NW of Seattle, WA).

### QUALITY CONTROL

We pour our ductile iron parts in our foundry, mold our own gaskets and we even make the threaded fasteners on many of our products.

Because we keep nearly all phases of manufacturing in-house, the supply chain is simplified and extremely efficient. Parts are made to our exact specifications and design changes can be made quickly.

Our customers enjoy our ability to quickly provide custom products designed to meet unique requirements.

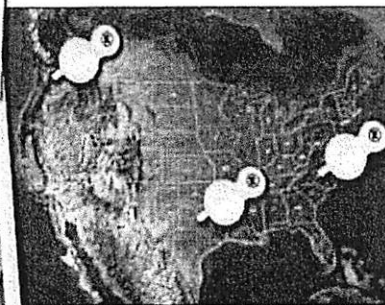

### FASTEST POSSIBLE DELIVERY

Our extensive inventory is now shipped out of one of our facilities in Seattle WA, Dallas TX and Charlotte NC. The strategic location of these operations allow us to deliver Romac products nearly anywhere in the country in two days or less.

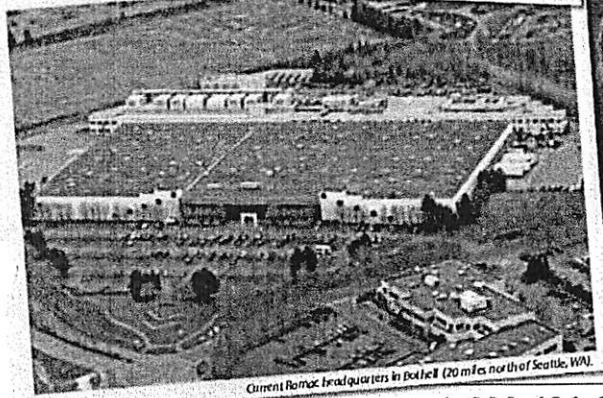

Current Romac headquarters in Bothell (20 miles north of Seattle, WA).

### TODAY

We're a little bigger, but our commitment to serving our customers and our customer's customers is as evident today as it was over 40 years ago.

AS 11/14

# ROMAC COUPLINGS

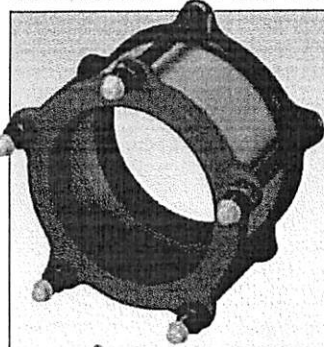

## 501 COLOR CODED COUPLINGS

Straight, transition and long barrel couplings. Introduced in 1970, the Romac 501 was the first color coded ductile iron coupling. Its interchangeable gaskets and end rings help to reduce inventory. Meets AWWA C219.

USE: Flexibly couple pipes of same or different diameters. For use on steel, cast iron, asbestos cement, plastic and other types of pipe.

SIZES: 2" - 24".

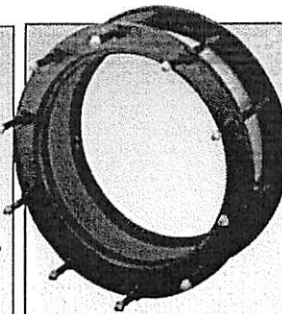

## 400 FABRICATED STEEL COUPLINGS

Fabricated steel coupling for pipe sizes 12" and larger. Meets AWWA C219.

USE: Flexibly couples pipes of same diameters. For use on steel, cast iron, asbestos cement, plastic and other types of pipe.

Also available with full restraint (400RG)

SIZES: 12" - 96" (larger sizes available upon request).



### RC501

USE: Used to flexibly couple pipes of different diameters. For use on steel, cast iron, asbestos cement, plastic and other types of pipe.

SIZES: 3" - 24".



### IC501

USE: Used to couple pipes of dissimilar metals. For use on steel, cast iron and other types of metallic pipe.

SIZES: 4" - 14".



### EC501

USE: Testing or capping of a pipeline. For use on steel, cast iron, asbestos cement, plastic and other types of pipe.

SIZES: 4" - 16".



### FCA501

USE: To provide a flanged to plain-end connection. For use on steel, cast iron, asbestos cement, plastic and other types of pipe.

SIZES: 3" - 16".



### FC400

USE: Used to flexibly couple pipes of different diameters. For use on steel, cast iron, asbestos cement, plastic and other types of pipe.



### RC400

USE: Used to couple pipes of dissimilar metals. For use on steel, cast iron and other types of metallic pipe.



### TC400

USE: Connects pipes of different known outside diameters in the same nominal size. For use on steel, cast iron, asbestos cement, plastic and other types of pipe.



### IC400

USE: To provide a flanged to plain-end connection. For use on steel, cast iron, asbestos cement, plastic and other types of pipe.

## EXTENDED RANGE COUPLINGS

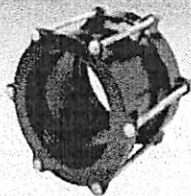

### XR501

USE: Flexibly couples pipe of widely different diameters (a range of IPS through Class 200 AC Pipe). For use on steel, cast iron, asbestos cement, plastic and other types of pipe.

SIZES: 4" - 12".

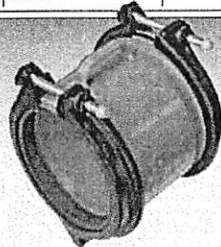

### MACRO™ - Two bolt coupling

USE: Flexibly couples pipes of widely differing diameters. For use on steel, cast iron, asbestos cement, plastic and other types of pipe.

SIZES: 4" - 12".

## SPECIALTY COUPLINGS

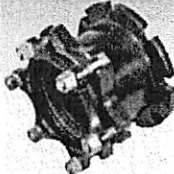

### FCG

USE: Provides a flexible flanged to plain-end connection.

SIZES: 3" - 12".

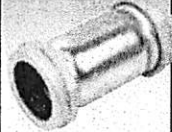

### 702

USE: Flexibly couples pipes of same diameters. For use on steel or plastic pipe.

SIZES: 1/2" - 2".



### 511

USE: Flexibly couples pipes of the same or different diameters. For use on steel, copper and PVC pipe.

SIZES: 1/2" - 12".

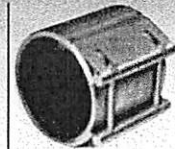

### ARMOR LINK

USE: Couples pipes of same diameters. For use on steel, cast iron, A/C, concrete, PVC and HDPE pipe.

SIZES: 4" - 24".

## DISMANTLING JOINTS

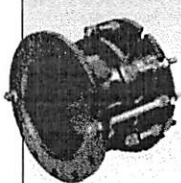

### DJ400

Adjustable telescoping restraint with tie-rods.

SIZES: 3" - 96".

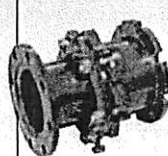

### DJ405

Adjustable telescoping restraint.

SIZES: 3" - 24".

Ideal for systems that require periodic maintenance, Romac Dismantling Joints can be adjusted to a desired length to allow access for installation or removal of valves and other fittings.

## RESTRAINT COUPLINGS

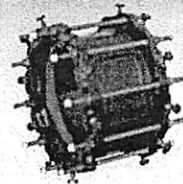

### 400RG & 400RG-PVC

USE: Couples pipe and provides restraint.

SIZES: 12" - 48".

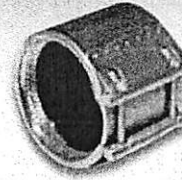

### ARMOR LOCK

USE: Couples pipe and provides restraint.

SIZES: 4" - 12".

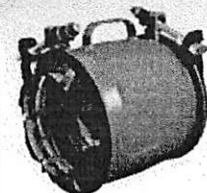

### ALPHA

USE: Couples pipe and provides restraint.

SIZES: 4" - 12".

## EQUIPMENT CONNECTION FITTING

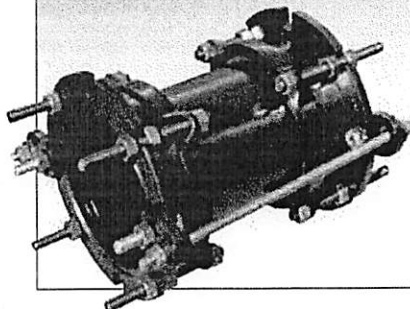

### ECF400

Equipment connection fitting.

Used to provide offset, deflection and restraint for systems with misaligned flanges.

SIZES: 3" - 96".

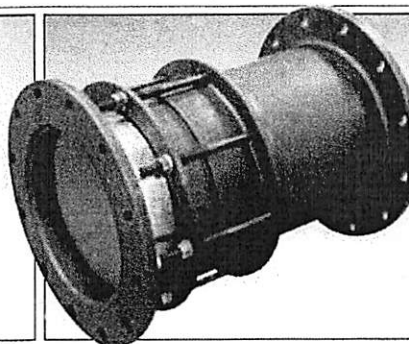

### EXPANSION JOINTS

Steel expansion joints. For use in pipelines where larger than usual longitudinal movements are concentrated. For use on steel, cast iron, plastic and other types of pipe.

SIZES: 3" - 96".



AB 11/14

## ROMAC REPAIR CLAMPS



**ALL STAINLESS STEEL REPAIR CLAMPS**  
Provides full circumferential repair of splits and holes. For use on steel, cast iron, asbestos cement, plastic and other types of pipe. Tapped outlets available.

SS1 - single section, 2"-12" (.40" range).  
SS2 - two section, 4"-14" (.80" range).  
SS3 - three section, 10" and larger (1.20" range).

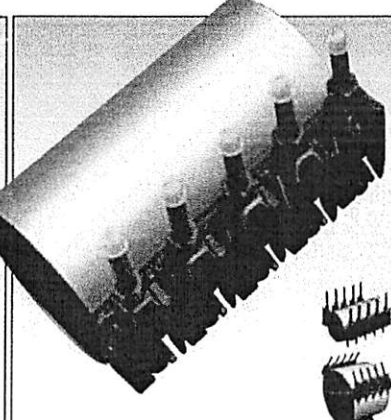

**CAST LUG REPAIR CLAMPS**  
Provides full circumferential repair of splits and holes. For use on steel, cast iron, asbestos cement, plastic and other types of pipe. Tapped outlets available.

CL1 - single section, 2"-12" (.40" range).  
CL2 - two section, 4"-14" (.80" range).  
CL3 - three section, 10" and larger (1.20" range).

**SPECIALTY REPAIR CLAMPS**



**SC**  
USE: Repair splits and holes in steel, cast iron, asbestos cement, plastic and other types of pipe.  
SIZES: 1/2" - 8".

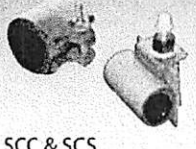

**SCC & SCS**  
USE: Full circumferential repair for steel and copper pipe.  
SIZES: 1/2" - 2".

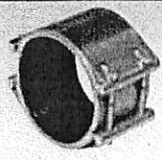

**ARMOR SEAL**  
USE: Provides full circumferential repair of splits, holes and breaks. Can also be used as a coupling.  
SIZES: 4" - 24".



**C**  
USE: Used to repair splits and holes. For use on steel, cast iron and asbestos cement pipe.  
SIZES: 1/2" - 12".

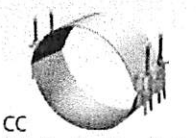

**CC**  
USE: Repair splits and holes in steel, cast iron, asbestos cement, plastic and other types of pipe.  
SIZES: 10" - 30".

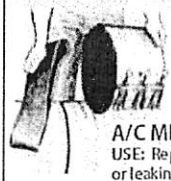

**A/C ME BAND**  
USE: Repair broken or leaking A/C couplings.  
SIZES: 4" - 16".

**BELL JOINT LEAK CLAMPS**



**416 & 418**  
USE: For repair or prevention of leaks in caulked or rubber gasketed joints on ductile iron pipe. 418 is for use on cast iron pipe.  
SIZES: 12" - 24".



**516**  
USE: For the repair or prevention of leaks in bells, caulked or rubber ring joints. For use on cast iron, ductile iron and C900 PVC pipe.  
SIZES: 4" - 14".

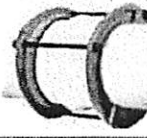

**517**  
USE: For repair or prevention of leaks in bells or rubber ring joints. For use on IPS PVC pipe.  
SIZES: 4" - 12".

## ROMAC SEWER PRODUCTS



**CB SEWER SADDLE**  
USE: For use on steel, cast iron, A/C, plastic and other types of pipe.  
SIZES: 6" - 56".



**501 COUPLING FOR SEWER**  
USE: Flexibly couples pipe of same or different diameters. For use on steel, cast iron, asbestos cement, plastic and other types of pipe.  
SIZES: 4" - 12".



**LSS1, LSS2 & LSS3**  
USE: Provides repair of splits and holes in steel, cast iron, A/C, plastic and other types of pipe.  
SIZES: 4" - 24".

## MISCELLANEOUS

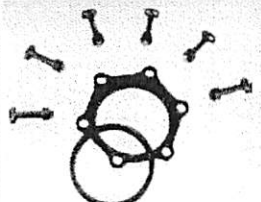

**MJ ACCESSORY PACK**  
Includes ductile iron gland, gasket, t-bolts and nuts.  
SIZES: 2" - 12".



**HYDRANT GASKETS**  
Valve gaskets compatible with most common fire hydrants.  
SIZES: 5" - 5 1/2".

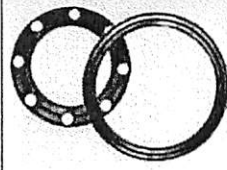

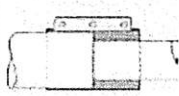

**GASKETS**  
Romac manufactures gaskets for many water and wastewater applications.



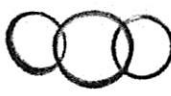



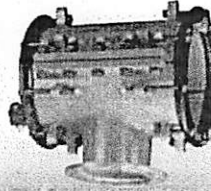
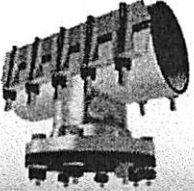
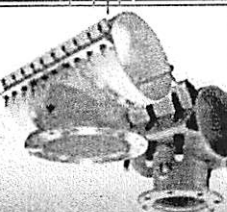
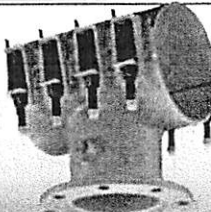
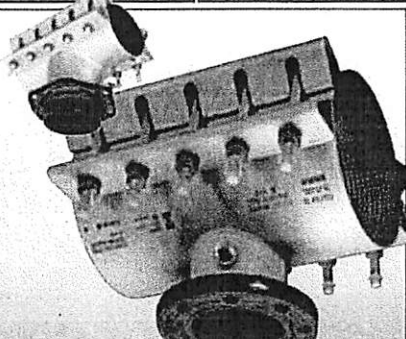
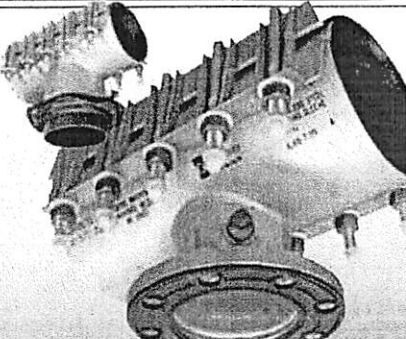

**TRANSITION CLAMP FOR SEWER**  
USE: Joins sewer pipe of different diameters. For use on steel, cast iron, asbestos cement, plastic and other types of pipe.  
SIZES: 4" - 20".

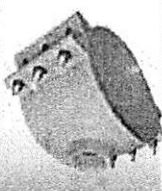

**SEWER GASKETS**  
A/C x PVC transition gaskets. Sizes: 4" - 8".  
MJ x SDR35 (PVC sewer) transition gaskets. Sizes: 4" - 24".  
LCT Manhole adapter gaskets. Sizes: 4" - 27".

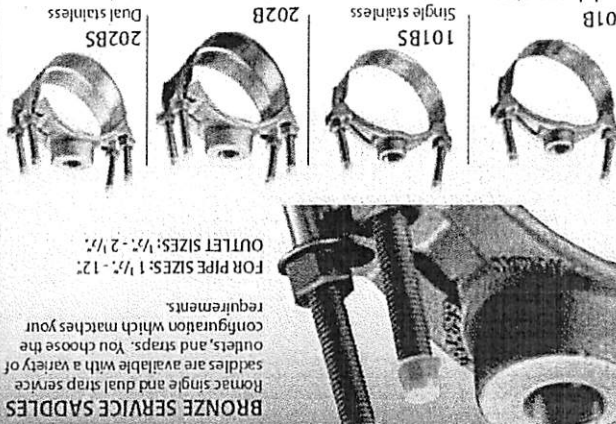
<p><b>FTS445</b> Fabricated steel tapping sleeve for weld-on outlets.</p> <p>FOR PIPE SIZES: 6" - 96" OUTLET SIZES: 4" - 24"</p> 	<p><b>FTS435</b> Fabricated steel tapping sleeve for all sizes of concrete cylinder pipe.</p> <p>OUTLET SIZES: Determined by application.</p> 	<p><b>FTS425</b> Fabricated steel tapping sleeve with side and end gasket seals.</p> <p>FOR PIPE SIZES: 12" - 96" OUTLET SIZES: (larger sizes upon request)</p> <p>4" through size-on-size.</p> 
<p><b>SST-X</b> Stainless steel line stopping sleeve.</p> <p>Compatible with most line stopping equipment.</p> <p>FOR PIPE SIZES: 4" - 12"</p> 	<p><b>FTS420 &amp; STS420</b> Fabricated tapping sleeves with triangular side bars. Meets the requirements of MSS SP-124 and AWWA C223.</p> <p>FOR PIPE SIZES: 6" - 42" OUTLET SIZES: 3" - 24"</p> 	<p><b>FTS419</b> Fabricated steel tapping sleeve with drop-in bolts. Meets the requirements of MSS SP-124 and AWWA C223.</p> <p>FOR PIPE SIZES: 4" - 24" OUTLET SIZES: 3" - 12"</p> 
<p><b>SST III</b> All stainless steel tapping sleeve with triangular sidebars, and full circumferential seal. Available with ductile iron flange, stainless steel flange or MJ outlet. Meets MSS SP-124 and AWWA C223.</p> <p>FOR PIPE SIZES: 4" - 30" OUTLET SIZES: up to 12"</p> <p>SST III MJ SST III with MJ outlet.</p> 		<p><b>SST</b> The original all stainless steel tapping sleeve with a full circumferential seal. Available with ductile iron flange, stainless steel flange or MJ outlet. Meets MSS SP-124 and AWWA C223.</p> <p>FOR PIPE SIZES: 4" - 24" OUTLET SIZES: up to 12"</p> <p>SSTM SST with MJ outlet.</p> 

**ROMAG TAPPING SLEEVES**

<p><b>FTS420T</b> Fabricated steel tapping saddle. For use on steel, cast iron, A/C, plastic and other types of pipe.</p> <p>FOR PIPE SIZES: 10" - 24" OUTLET SIZES: 1/2" - 4"</p> 	<p><b>306</b> All stainless steel service saddle. For use on steel, cast iron, plastic and other types of pipe.</p> <p>FOR PIPE SIZES: 2" - 12" OUTLET SIZES: 1/2" - 2"</p> 	<p><b>BRONZE SERVICE SADDLES</b> Romac single and dual strap service saddles are available with a variety of outlets, and straps. You choose the configuration which matches your requirements.</p> <p>FOR PIPE SIZES: 1/2" - 12" OUTLET SIZES: 1/2" - 2 1/2"</p> <p>101B Single bronze strap, steel saddle. 101BS Single stainless steel strap. 202B Dual bronze straps, steel saddle. 202BS Dual stainless steel straps.</p> 	
<p><b>305</b> All stainless steel service saddle. For use on steel, cast iron, plastic and other types of pipe.</p> <p>FOR PIPE SIZES: 10" - 24" OUTLET SIZES: 1/2" - 3"</p> 	<p><b>304</b> All stainless steel service saddle. For use on steel, cast iron, plastic and other types of pipe.</p> <p>FOR PIPE SIZES: 2" - 8" OUTLET SIZES: 1/2" - 1"</p> 	<p><b>101 SERVICE SADDLES</b> Romac 101 single-strap service saddles are cast of ductile iron poured in our own U.S. foundry. A wide variety of outlets, coatings, and strap materials are available. You choose the configuration which matches your requirements.</p> <p>FOR PIPE SIZES: 1 1/2" - 12" OUTLET SIZES: 1/2" - 2 1/2"</p> <p>101U Shop coat with u-bolt. 101NU Nylon coated with u-bolt. 101S Shop coat with stainless steel strap. 101NS Nylon coated with stainless steel strap.</p> 	

<p><b>202 SERVICE SADDLES</b> Romac 202 dual-strap service saddles are cast of ductile iron poured in our own U.S. foundry. A wide variety of outlets, coatings, and strap materials are available. You choose the configuration which matches your requirements.</p> <p>FOR PIPE SIZES: 2" - 24" OUTLET SIZES: 1/2" - 2 1/2"</p> <p>202U Shop coat with u-bolt. 202NU Nylon coated with u-bolt. 202S Shop coat with stainless steel strap. 202NS Nylon coated with stainless steel strap.</p> 			
---	--	--	--

**ROMAG SERVICE SADDLES**

Handwritten signature or initials.

# ROMAC RESTRAINT SYSTEMS

AS  
11/11/14



**GRIP RING™**  
Full circumferential pipe restraint. The GripRing uses a standard mechanical joint gasket and t-bolts. There are no radial bolts for the installer to forget to tighten. When the t-bolts on the gland are tightened, the GripRing restraint is engaged.

FOR PIPE SIZES: 4" - 12"



**PIRANHA™ RESTRAINT GASKET**  
Dual function gasket simultaneously seals and restrains. Stainless steel teeth vulcanized into the rubber, grip and hold the pipe in place. For pipe compatibility, see Romac catalog.

CURRENTLY FOR PIPE SIZES: 4" - 12"

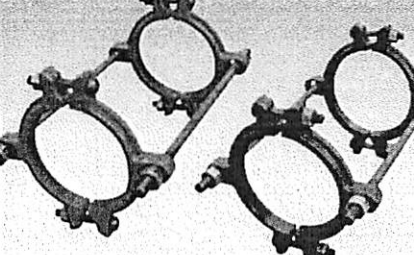

**600 Series**  
Provides restraint for bell and spigot joints, transitions, couplings and mechanical joints.

For use on ductile iron, C900 and IPS size PVC.

FOR PIPE SIZES: 4" - 12"

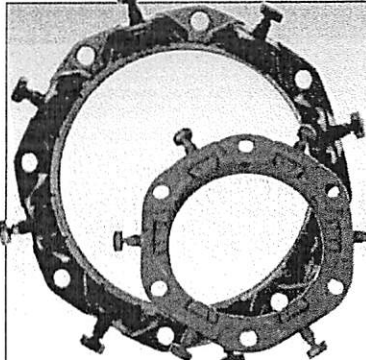

**RomaGrip™**  
Lug style mechanical joint restraint for use on ductile iron pipe and steel pipe (3 - 12 inch).

FOR PIPE SIZES: 3" - 48"

**PVC-RomaGrip™**  
For use on C900 4 - 12 inch, C905 14 - 24 inch and IPS PVC 3 - 12 inch Class 160 and greater, Sch 40 and 80. Contact Romac for C909 and thin wall IPS (less than Class 160, etc.).

FOR PIPE SIZES: 3" - 24"

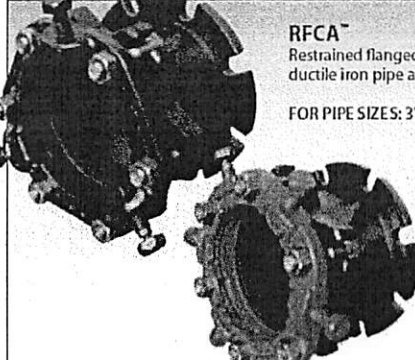

**RFCA™**  
Restrained flanged coupling adapter for use on ductile iron pipe and steel pipe (3 - 12 inch).

FOR PIPE SIZES: 3" - 24"

**PVC-RFCA™**  
Restrained flanged coupling adapter for use on PVC pipe.

FOR PIPE SIZES: 3" - 24"



**400RG**  
Fully restrained coupling for use on ductile iron. Used to couple and restrain plain-end ductile iron pipe.

FOR PIPE SIZES: 12" - 48"

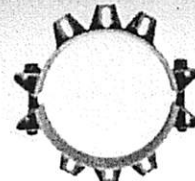

**470**  
Pipe restraint for mechanical joint fittings, bell and spigot joints and bolted sleeve type couplings. For use on PVC pipe.

FOR PIPE SIZES: 14" - 30"

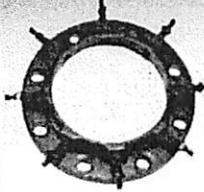

**FIELD FLANGE**  
Provides restrained connection to join plain-end pipe to flanged fittings without threading or welding. For use on steel and ductile iron pipe.

FOR PIPE SIZES: 4" - 12"



**DUCLUG**  
Provides restraint for mechanical joints to prevent pull-out for 3/4" rod.



**90° EYE BOLT**  
Provides restraint for mechanical joints to prevent pull-out for 3/4" rod.



**M11 Harness Restraint**  
Provides restraint for mechanical couplings on steel pipelines. For use on steel, cast iron, plastic and other types of pipe.

FOR PIPE SIZES: 6" - 96" for steel pipe. Other sizes available.



**HARNES LUGS**  
Provides restraint for flanged connections.

FOR FLANGE SIZES: 3" - 72"

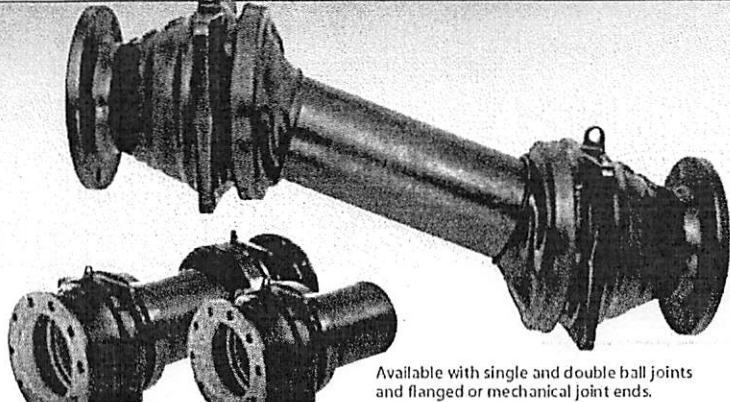

**FJ RESTRAINT**  
FLEXIBLE EXPANSION JOINT

Accommodates expansion, contraction, rotation, offset and settlement all at the same time.

The FJ Flexible Expansion Joint requires no threaded fasteners for assembly. The FJ's advanced design eliminates the need for flanged assembly connections in the casing. By eliminating unnecessary components, the compact design allows a lightweight assembly for ease of installation.

SIZES: 3" - 24". Larger sizes available.

Available with single and double ball joints and flanged or mechanical joint ends.



AS  
11/11/14

Telephone: 602.233.0071  
Sales Fax: 602.272.4847  
Administrative Fax: 602.233.9152

201 South 61<sup>st</sup> Avenue  
Phoenix, Arizona 85043

November 11, 2014

Mr. Andrew Siderius  
Division Manager  
Western Nevada Supply  
950 S. Rock Blvd.  
Sparks, NV 89431

RE: Western Nevada Supply - Vinyltech PVC Pipe - Master Stocking Distributor Re-seller

Vinyltech Corporation is a manufacturer of (American Water Works Association) AWWA C900, C905 water, ASTM D 3034 and ASTM F 679 sewer main PVC pipe products. We have been producing these products since 1982 at our plant in Phoenix, Arizona. We maintain one of the largest west coast production facilities and are one of the few American owned pipe producers with service to the northern Nevada area. Vinyltech is wholly owned by Ottertail Corporation, which is publicly traded on the NASDAQ.

Western Nevada Supply is an authorized Vinyltech distributor and represents all products we produce.

Please call with any questions.

Sincerely,  
Vinyltech Corporation

A handwritten signature in black ink, appearing to read "Brent Hildyard".

Brent Hildyard, Vice President





**ROMAC  
INDUSTRIES,  
INC.**

21919 20th Avenue SE • Suite 100  
Bothell, WA 98021

AS  
11/14/14

To whom it may concern-

Western Nevada Supply Co is set up as a Romac Industries distributor and can make purchases.  
If you have any questions please let me know.

Thank you-

Jessica (JR) Resler

Romac | Assistant Inside Sales Manager  
21919 20th Ave SE, Suite 100  
Bothell, Washington 98021

Dir: 425.951.6223

Fax: 425.951.6201



1526 Parkway Dr. Folsom, CA 95630

AS  
11/11/14

Date: November 11, 2014

RE: Carson City Purchasing and Contracts Specifications

To Whom It May Concern,

This letter is to inform you that Western Nevada Supply is an authorized representative and distributor of Mueller products. Mueller's standard warranty will apply to all material purchases by Western Nevada Supply.

I would like to thank you and feel free to call with any comments, questions or concerns.

Sincerely,

Josh Swanson  
N. CA/NV Sales Rep.  
916-802-8772  
[jswanson@muellercompany.com](mailto:jswanson@muellercompany.com)

A  
11/11/14

DIAMOND  PLASTICS®  
CORPORATION

November 11, 2014

To Whom It May Concern:

Diamond Plastics is pleased to announce Western Nevada Supply is an authorized distributor of Diamond Plastics' PVC piping products.

If there are any questions, please do not hesitate to call me at 402/617-2096.

Sincerely,

DIAMOND PLASTICS CORPORATION



Dennis E. Bauer  
Vice President Sales & Marketing

DB:cmk



AS  
11/11/14

November 11, 2014

*To Whom It May Concern:*

***RE: Authorized Distributor for Star Pipe Products***

*This letter is to certify that Western Nevada Supply in Sparks, Nevada, is an authorized distributor for Star Pipe Products.*

*If you have any further questions, please feel free to contact me.*

*Sincerely,*

Kristin Reid  
Product Manager  
Star Pipe Products  
e-mail: [kristinr@starpipelineproducts.com](mailto:kristinr@starpipelineproducts.com)

**STAR® PIPE PRODUCTS**

4018 WESTHOLLOW PARKWAY HOUSTON, TEXAS 77082-4604  
[www.starpipelineproducts.com](http://www.starpipelineproducts.com)

T: 800.999.3009  
F: 281.558.9000







[www.gblueteam.com](http://www.gblueteam.com)

AB  
11/11/14

November 11, 2014

Re: Carson City Purchasing and Contracts  
Request for bid #1415-092

Exhibit C: Bidders Warranty

Each individual manufacturer provides their own terms, conditions, warranties, and limitations based on the products produced. The specific terms and warranties are available on their respective websites and can be produced for review if requested. All products provided for this request for bid are subject to the manufacturers standard terms and warranties and no additional warranties are offered as part of this bid package.

Sincerely

Andrew Siderius  
Waterworks Division Manager

\*  
11/11/14

**CARSON CITY PURCHASING AND CONTRACTS**  
**201 North Carson Street, Suite 3**  
**Carson City, NV 89701**  
**775-283-7137/FAX 887-2107**  
**<http://www.carson.org/index.aspx?page=998>**  
**NOTICE TO BIDDERS**  
**BID #1415-092**  
**Warehouse Inventory Parts**

**Addendum No. 1**

Please make the following additions/changes/clarifications to the above referenced project:

1. Please note that the date and time of the bid submittal/opening has been changed. Bid Submittal has been changed to November 12, 2014 @11:00 a.m. and the bid opening has been changed to November 12, 2014 @11:10 a.m. The location of the bid opening is unchanged.

*End of Addendum 1*

x   
Andrew Sieranis



[www.gblueteam.com](http://www.gblueteam.com)

*AS*  
*11/11/14*

November 11, 2014

Re: Carson City Purchasing and Contracts  
Request for bid #1415-092

Exhibit E: Bid Response Additional Space

None Required

Sincerely

Andrew Siderius  
Waterworks Division Manager



[www.gobluesteam.com](http://www.gobluesteam.com)

AS  
11/11/14

November 11, 2014

Re: Carson City Purchasing and Contracts  
Request for bid #1415-092

Exhibit F: Supplemental Materials

None Required

Sincerely

Andrew Siderius  
Waterworks Division Manager



[www.goblue team.com](http://www.goblue team.com)

AS  
11/11/14

November 11, 2014

Re: Carson City Purchasing and Contracts  
Request for bid #1415-092

Exhibit G: Exception Summary

None Required

Sincerely

Andrew Siderius  
Waterworks Division Manager