



STAFF REPORT

Report To: Redevelopment Authority

Meeting Date: December 6, 2018

Staff Contact: Lee Plemel, Community Development Director

Agenda Title: For Possible Action: To make a recommendation to the Board of Supervisors regarding the expenditure of up to \$400,360 from the Fiscal Year 2019 Redevelopment Revolving Fund for the Bob Boldrick Theater rehabilitation project. (Lee Plemel, lplemel@carson.org)

Staff Summary: The Redevelopment Authority allocated \$247,996 in the FY 2019 budget for the Bob Boldrick Theater (Community Center) rehabilitation project, with direction from the Board of Supervisors to include the option of using any roll-forward funds from the prior years' budget for the project. Upon completion of the FY 2018 audit, an additional \$152,364 is available from the Redevelopment Revolving Fund and not allocated to other projects at this time, for a total available of up to \$400,360 for this project. The project will replace the theater seats and make other improvements to refurbish the theater interior. The Redevelopment Authority must make a recommendation to the Board of Supervisors regarding the authorization of any expenditure from the Redevelopment Revolving Fund that is incidental to the carrying out of the Redevelopment Plan.

Agenda Action: Formal Action/Motion

Time Requested: 10 minutes

Proposed Motion

I move to approve and recommend that the Board of Supervisors authorize the expenditure of \$252,996 [or other amount determined by the Redevelopment Authority] from the Fiscal Year 2019 Redevelopment Revolving Fund for the Bob Boldrick Theater rehabilitation project.

Board's Strategic Goal

Economic Development

Previous Action

October 18, 2018: The Board of Supervisors approved the purchase of the theater replacement seats. (See attached Board staff report and action from October 18, 2018.)

November 5, 2018: The Redevelopment Authority Citizens Committee voted 6-0 (1 vacancy) to authorize the expenditure of \$252,996 for the project. (At the time of RACC action, which was before completion of the FY 2018 audit, \$252,996 was the amount that was known to be available for the project.)

Background/Issues & Analysis

The Bob Boldrick Theater rehabilitation project includes the replacement of the theater seats, new carpeting, painting, and replacement of the acoustic panes. The FY 2019 Redevelopment budget included \$247,996 for this project. When the Redevelopment Authority approved the current Redevelopment Discretionary Funds Tentative Expenditures plan in March 2018, it included direction to reallocate any extra FY 2019 Redevelopment funds to the theater project. There was \$5,000 allocated to purchase a new portable sound system in FY 2018 that is unspent and, after discussion with Parks staff, it was been determined that existing

portable sound equipment is adequate and there is no need for the additional purchase. Therefore, city staff and RACC recommended adding the \$5,000 to the theater project for a total of \$252,996.

The FY 2018 audit was completed in November, and an additional \$152,364 (including the sound system funds) was identified as undesignated funds and available for use in the FY 2019 budget. When added to the original \$247,996 identified for this project in the FY 2019 budget, a total of up to \$400,360 may be authorized for the project from the Redevelopment Revolving Fund.

The following budget was presented with the bid for the theater seats, with the Redevelopment Revolving Fund budget updated to reflect the amount proposed with this item:

Account Number(s)	Account Description	Fiscal Year	Project Budget
210-0000-451.70-40	Capital Project / CC Theater Improvements	FY2018	\$ 23,018
254-5046-452.70-40	Q18 Capital Projects / CC Theater Improvements	FY2018	\$ 174,834
254-5046-452-70-40	Q18 Capital Projects / CC Theater Improvements	FY2019	\$ 138,209
603-0000-463.70-40	Redevelopment Capital Projects	FY2019	\$ 252,996
TOTAL PROJECT BUDGET			\$ 589,057

The project can be completed with the proposed funding of \$252,996 from the Redevelopment Fund. This would allow the extra \$147,364 to be used on other Redevelopment programs or projects. However, the addition of Redevelopment Funds into the project budget would allow for the other Question 18 and/or Capital Projects funds to be used for their applicable purpose on other projects in the City. The Redevelopment Authority and Board of Supervisors may consider increasing the amount of funding from Redevelopment above the recommended amount of \$252,996 and reduce funding from other sources commensurately.

If you have any questions regarding this item, please contact Lee Plemel at 283-7075 or lplemel@carson.org.

Applicable Statute, Code, Policy, Rule or Regulation

NRS 279.382 – 279.685

Financial Information

Is there a fiscal impact? Yes No

If yes, account name/number: 603 Redevelopment Revolving Fund, Acct #: 603-0000-463-70-40

Is it currently budgeted? Yes No

Explanation of Fiscal Impact: The funds are budgeted in the FY 2019 Redevelopment budget.

Alternatives

Modify the proposed funding.

Attachments:

- 1) Theater seat information

Board Action Taken:

Motion: _____

1) _____

2) _____

Aye/Nay

(Vote Recorded By)



STAFF REPORT

Report To: Board of Supervisors

Meeting Date: October 18, 2018

Staff Contact: Carol Akers and Jennifer Budge

Agenda Title: For Possible Action: To approve the purchase of Navetta Theater Seating with William Peterson and Associates through joinder Contract No. 170302 with TIPS-USA, for an amount not to exceed \$222,406.80. (Carol Akers, CAkers@carson.org and Jennifer Budge, JBudge@carson.org)

Staff Summary: This contract is for the purchase and installation of new theater seats at the Carson City Community Center's Bob Boldrick Theater. The contract scope includes removal of the existing theater seating, and furnishing and installing new theater seats for \$202,188.00, plus a contingency amount of \$20,218.80, for the total amount of \$222,406.80, to be funded from the Quality of Life and Redevelopment Revolving Funds. William Peterson and Associates is an authorized dealer of Navetta Theater Seating through the awarded contract holder TIPS-USA Furniture, Contract No. 170302. The city has selected the CAL133 foam option, as recommended by the Fire Department to be in compliance with fire code.

Agenda Action: Formal Action/Motion

Time Requested: 5 min.

Proposed Motion

To approve the purchase of Navetta Theater Seating with William Peterson and Associates through joinder Contract No. 170302 with TIPS-USA, for an amount not to exceed \$222,406.80.

Board's Strategic Goal

Efficient Government

Previous Action

Background/Issues & Analysis

Applicable Statute, Code, Policy, Rule or Regulation

NRS 338.195

Financial Information

Is there a fiscal impact? Yes No

If yes, account name/number: Quality of Life Fund Account #254-5046-452-70-40, Project #010711 and Redevelopment Revolving Fund #603-0000-463-70-40, Project #010711.

Is it currently budgeted? Yes No

Explanation of Fiscal Impact: \$242,996.00 was budgeted in FY19 in the Redevelopment Revolving Fund and \$125,253.00 is available in the Quality of Life Fund to be carried forward from FY18.

Alternatives

Do not approve joinder contract and provide alternative direction to staff.

Board Action Taken:

Motion: APP

- 1) BB
- 2) KA

Aye/Nay
5/0

SM
(Vote Recorded By)

Bob Boldrick Theater Project - Carson City, NV

REV: 12

10/10/2018

NAVETTA Theater Seating

by

William Peterson / Associates

Tandem Commercial Installation - Removal & Installation

TIPS-USA Contract #170302

Shuttle Systems LLC DBA Navetta

COMPLETE THEATER

Description	QTY	Model #	Unit Price	Freight	Total Unit	Extended
Theater Seating (Cal 133 Foam) Back: upholstered w/lumbar plastic back Back: Height 35" Seat: upholstered w/gravity up-lift Seat Width: 23" - TBD Plastic seat bottom Armrests - Wood End Panels: High Trap, Laminate Fabric: STD Sherpa Shire Footplate: Oval Structure: Black Metal- Plastic 117 Row Letters 6 ADA Swing Away End Panels	609	S400	\$ 265.00	\$ 16.00	\$ 281.00	\$ 171,129.00
OPTION Theater Seating (Cal 117 Foam)	609	S400	\$ 202.50	\$ 16.00	\$ 218.50	\$ 133,066.50

Description	QTY	Model #	Unit Price	Freight	Total Unit	Extended
Removable seating chairs on bases	12	S400	INCLUDED			
Swing Away - ADA Seating	6	S400	INCLUDED			
Additional Seat / back covers	35		INCLUDED			
		Total Freight	\$	9,744.00		\$ 171,129.00

Aisle Lighting

LED Low Voltage lights - Beacon Series LED Low Voltage lights - Usher Series	133	BEACON	INCLUDED			
DC Transformer (will power 33 ights)	3		INCLUDED			

Installation

Installation of chair	609	\$	51.00	\$	31,059.00	
Option Removal and Disposal	609	\$	19.00	\$	11,571.00	

Approved Seats →

PROJECT TOTAL (Install / Removal) - Cal 133	\$	202,188.00
PROJECT TOTAL (Install / Removal) - Cal 117	\$	164,125.50

ABOUT THE S400

The S400 Contina Seating System provides elegant, comfortable, and reliable seating at an affordable price—perfect for auditoriums and other larger venues.



ABOUT THE S400

Specifications

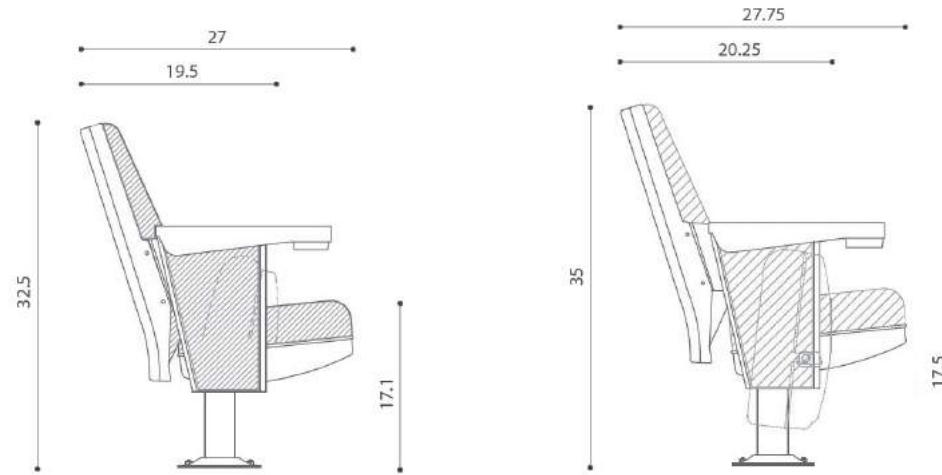

The frame has a durable and environmentally-friendly electrostatically applied powder coat finish, oven-baked at 392° F.

Conventional style curved cushion back with anatomic or concave style cushion seat.

Seatback height: 32.5" or 35". Width available: From 19" to 22".

ABOUT THE S400

Specifications

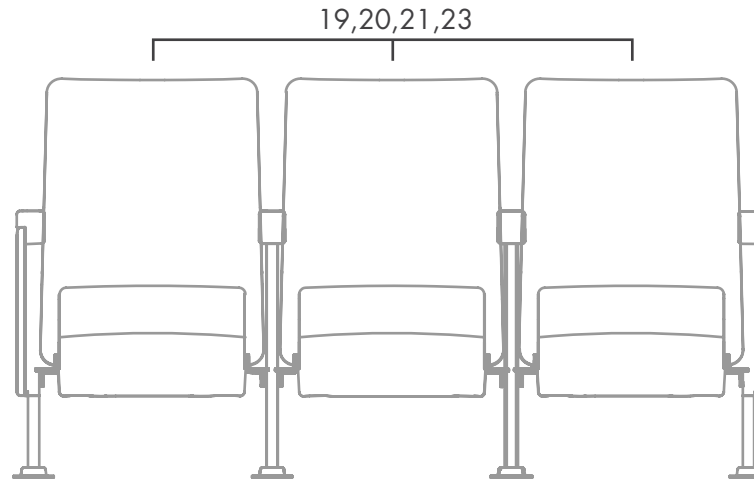

The frame has a durable and environmentally-friendly electrostatically applied powder coat finish, oven-baked at 392° F.

Conventional style curved cushion back with anatomic or concave style cushion seat.

Seatback height: 32.5" or 35". Width available: From 19" to 22".

ABOUT THE S400

Seat Construction

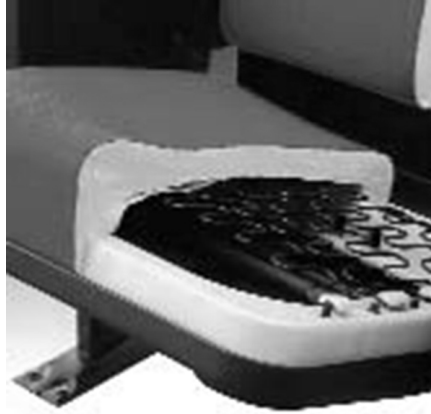

- Counterbalance mechanism provides for quiet seat return
- Serpentine springs for added comfort
- Vented pans allows the cushion foam to sustain a long life

ABOUT THE S400

Cushion Construction

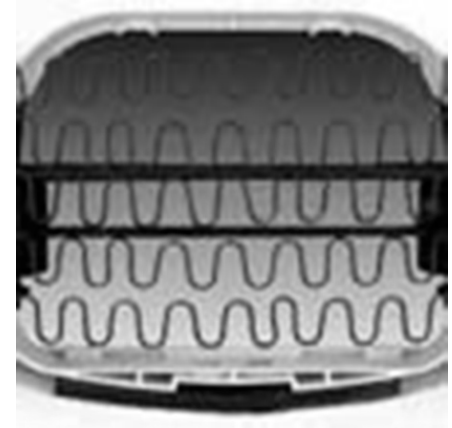

- Contoured shape for maximum comfort
- Cold molded foam for comfort and lasting cushion lifespan
- 4" foam crown on seat foam and serpentine spring support

S400 OPTIONS

S400 options:

3) Upholstered or wood
end panel with fixed arm,
with or without cup holder





Naaman Forest