



## STAFF REPORT

**Report To:** Board of Supervisors                      **Meeting Date:** December 3, 2020

**Staff Contact:** Carol Akers, Purchasing and Contracts Administrator and Rich Hardcastle, Fleet Manager

**Agenda Title:** For Possible Action: Discussion and possible action regarding the purchase of 32 vehicles for several departments throughout the City, utilizing the State of Nevada's competitive bid list and cooperative purchasing agreements through Sourcewell and HGACBuy for a total not to exceed amount of \$2,594,450.39. (Carol Akers, CAkers@carson.org and Rich Hardcastle, RHardcastle@carson.org)

Staff Summary: Multiple city departments are looking to replace vehicles due to the age and/or condition of the vehicles. The vehicles being replaced are at the end of their useful lives and it is not cost-effective to continue to maintain these vehicles. Staff seeks approval for a total of 32 vehicles to be replaced. These requested purchases were planned for and are funded as part of the approved fiscal year ("FY") 2021 Capital Improvement Vehicle Replacement Program or funded by grants/donations.

**Agenda Action:** Formal Action / Motion                      **Time Requested:** 5 minutes

---

### Proposed Motion

I move to approve the purchases as presented.

### Board's Strategic Goal

Efficient Government

### Previous Action

The revised Capital Improvement Program for FYs 2021-2025 was approved on September 17, 2020.

The partial Capital Improvement Program was approved on May 7, 2020.

### Background/Issues & Analysis

Please refer to the attached spreadsheet for all replacement information. These proposed purchases were approved as part of the FY 2021 vehicle replacement program, including one new vehicle for the Parks, Recreation, and Open Space - Park Ranger. The vehicles being replaced are at the end of their useful lives and will be sent to auction for sale.

In addition, the following vehicles will be added to the fleet:

The Sheriff's Office will be using K9 donation funds for the purchase of a new Chevy Tahoe and the Fire Department Fuels Program will be using funding received through the NV Division of Forestry Grant approved by the Board of Supervisors on October 15, 2020 for the purchase of a new Ford F350 and a CAT Track Loader.

All quotes have been verified and all vendors have confirmed they will honor quotes as provided.

Contracts being utilized:

1) State of Nevada Contracts: Vehicle Contract #'s 99SWC-S490 and 99SWC-609

(All vehicle contracts expire 6/30/2021)

[https://purchasing.nv.gov/Contracts/Documents/Vehicle\\_Purchases/](https://purchasing.nv.gov/Contracts/Documents/Vehicle_Purchases/)

A. Michael Hohl Chevrolet

B. Capital Ford

C. Carson City Toyota

2) Sourcewell

A. Caterpillar Inc. Contract #032119-CAT (expires 5/13/2023)

<https://www.sourcewell-mn.gov/cooperative-purchasing/032119-cat#tab-contract-documents>

B. SSI Monroe Townmaster, LLC Contract #121918-MNR (expires 2/11/2023)

<https://www.sourcewell-mn.gov/cooperative-purchasing/121918-mnr#tab-contract-documents>

C. Curbtender Contract #091219-CRB (expires 11/15/2023)

<https://www.sourcewell-mn.gov/cooperative-purchasing/091219-crb#tab-contract-documents>

3) HGACBuy

A. Siddons-Martin Emergency Group, LLC Contract# FS12-19 (expires 11/30/2021)

<https://www.hgacbuy.org/contracts/documents/FS12-19/Siddons-Martin-Emergency-Group.pdf>

### **Applicable Statute, Code, Policy, Rule or Regulation**

NRS 332.195

### **Financial Information**

**Is there a fiscal impact?** Yes

**If yes, account name/number:** Capital Projects Fund, Vehicle Replacement Account / 2101002-507705

Capital Projects Fund, Landfill Equipment Account / 2103939-506502

Quality of Life Fund, Parks Equipment Account / 2545047-507775

Street Maint. Fund, Vehicle Replacement Account / 2563038-507705

Water Fund, Vehicle Replacement Account / 5203502-507705

General Fund, Sheriff K9 Donation Account / 1012012 501420

Grant Fund, FD Fuels Project# G25422100, Account / 2752505-501225

**Is it currently budgeted?** Yes

**Explanation of Fiscal Impact:** 2101002-507705 will be decreased by a not to exceed amount of \$1,436,530.13; the available balance is \$1,730,000.

2103939-506502 will be decreased by a not to exceed amount of \$393,453; the available balance is 419,140

2545047-507775 will be decreased by a not to exceed amount of \$30,190.47; the available balance is \$45,000.

2563038-507705 will be decreased by a not to exceed amount of \$327,689.74; the available balance is \$340,000.

5203502-507705 will be decreased by a not to exceed amount of \$201,302.19; the available balance is \$255,000.

Donation/Grant vehicles

1012012-501420 will be decreased by a not to exceed amount of \$45,464.75; the available balance is \$45,464.75.

Project# G25422100, Account / 2752505-501225 will be decreased by a not to exceed amount of \$159,820.11; the available balance is \$195,000.

**Alternatives**

Do not approve purchases and provide alternative direction to staff.

**Attachments:**

[FY20-21 Vehicles and Equipment BOS 12-03-20 np.pdf](#)

[12-03-20 Vehicle Quotes.pdf](#)

**Board Action Taken:**

Motion: \_\_\_\_\_

1) \_\_\_\_\_

2) \_\_\_\_\_

Aye/Nay

\_\_\_\_\_  
\_\_\_\_\_  
\_\_\_\_\_  
\_\_\_\_\_

\_\_\_\_\_  
(Vote Recorded By)

Fund	Dept.	Year	Equip #	Mileage	Years of Service	Type of Unit	FY 20/21 Budget	Vehicle cost	Replacement Vehicle Make and Model	Vendor	Contract/PO	BOS Date	
1	2103939-506502	LANDFILL	2012	7907	10,078	8 LF COMPACTOR	\$ 550,000.00	480,860.00	Aljon 500	Tri-County	Sole Source (20300122)	8/6/2020	
2	2103939-506502	LANDFILL	2014	8204	9,948	6 LF LOADER	\$ 350,000.00	393,453.00	Caterpillar 966M	Cashman	Sourcewell	12/3/2020	
							\$ 900,000.00	\$ 874,313.00					
3	2253026-507705	TRANSIT	2007	4005	57804	13 JAC BUS Cares Act	\$ 75,000.00	94,045.75	Dodge Ram Promaster	RO Bus Sales	State of Nevada	Approved by RTC 11/18/2020	
4	2253026-507705	TRANSIT	2012	4237	111793	8 JAC BUS Cares Act	\$ 165,000.00	137,580.00	Chevy Express 28' Arboc	Creative Bus			RFP
5	2253026-507705	TRANSIT	2012	4238	128612	8 JAC BUS Cares Act	\$ 165,000.00	137,580.00	Chevy Express 28' Arboc	Creative Bus			RFP
6	2253026-507705	TRANSIT	2012	4239	125157	8 JAC BUS Cares Act	\$ 165,000.00	137,580.00	Chevy Express 28' Arboc	Creative Bus			RFP
7	2253026-507705	TRANSIT	2011	4236	153,686	9 JAC BUS CIP	\$ 165,000.00	137,580.00	Chevy Express 28' Arboc	Creative Bus			RFP
8	2253026-507705	TRANSIT	2013	4240	115,309	7 JAC BUS CIP	\$ 165,000.00	137,580.00	Chevy Express 28' Arboc	Creative Bus			RFP
							\$ 900,000.00	\$ 781,945.75					
ST 5 YARD DUMP TRUCK													
9	2563038-507705	STREET MAINT	2006	6402	54,549	14 SANDER/PLOW	\$ 240,000.00	234,686.74	HV513/Monroe	SSI-Monroe	Sourcewell	12/3/2020	
10	2563038-507705	STREET MAINT	1994	6608	113,504	26 ST TRASH COMPACTOR	\$ 100,000.00	93,003.00	Curbtender Pup 6 Yard	Curbtender	Sourcewell	12/3/2020	
ST TRAILER TANDUM SIDE													
11	2563038-507705	STREET MAINT	2000	8815	0	20 DUMP	\$ 20,000.00	16,547.95	Trail King/TK60SSD	Pape / Split between ST, WW & Water	Purchased Under \$50k	PO 21200213	
							\$ 360,000.00	\$ 344,237.69					
12	2101002-507705	FD	2000	2212	104400	20 FD EXPEDITION PREV. 57	\$ 60,000.00				Has not been purchased		
13	2101002-507705	FD	2006	2222	97246	14 FD TAHOE BC BACKUP	\$ 50,000.00				Has not been purchased		
14	2101002-507705	FD	1998	7009	4000	22 PD PUMPER TRUCK E153	\$ 685,000.00	684,755.64	Pierce Pumper	Siddons-Martin Emergency Group, LLC	HGAC Buy FS19-21	12/3/2020	
15	5012525-507705	FD AMB	2012	3016	163,600	8 FD AMBULANCE R52 (Refurb)	\$ 150,000.00		F450 / EVG		Has not been purchased		
							\$ 945,000.00	\$ 684,755.64					
16	5103201-507705	WW	1990	8502	1,050	30 SM AIR COMPRESSOR	\$ 35,000.00	30,758.00	Atlas Copco/XAS250	H&E	Purchased Under \$50k	PO 21200187	
ST TRAILER TANDUM SIDE													
11	5103201-507705	WW	2000	8815	0	20 DUMP	\$ 20,000.00	16,547.95	Trail King/TK60SSD	Pape / Split between ST, WW & Water	Purchased Under \$50k	PO 21200213	
17	5103201-507705	WW	NEW	NEW		WWTP VAC TRAILER	\$ 50,000.00	40,257.00	Pacific Tek/PV350	Haaker	Purchased Under \$50k	PO 21200185	
							\$ 105,000.00	\$ 87,562.95					
18	5203502-507705	WATER	1997	5419	89,566	23 WM PICKUP	\$ 45,000.00	26,371.99	Chevrolet Silverado 1500	Michael Hohl Chevy	State of Nevada	12/3/2020	
19	5203502-507705	WATER	2008	5523	101,250	12 WM PICKUP	\$ 45,000.00	33,380.00	Ford F250	Capital Ford	State of Nevada	12/3/2020	
WM 3/4 TON UTILITY													
20	5203502-507705	WATER	1992	5601	33,300	28 HYDRUALIC TRUCK	\$ 165,000.00	141,550.20	Chevy 6500	Michael Hohl Chevy	State of Nevada	12/3/2020	
ST TRAILER TANDUM SIDE													
11	5203502-507705	WATER	2000	8815		20 DUMP	\$ 20,000.00	16,547.95	Trail King/TK60SSD	Pape / Split between ST, WW & Water	Purchased Under \$50k	PO 21200213	
							\$ 275,000.00	\$ 217,850.14					
4	2101002-507705	PARKS	1990	5015	66639	30 PA PICKUP	\$ 35,000.00	31,426.00	Ford F150	Capital Ford	State of Nevada	12/3/2020	
22	2101002-507705	PARKS	1996	5025	68900	24 PA PICKUP	\$ 35,000.00	31,426.00	Ford F150	Capital Ford	State of Nevada	12/3/2020	
23	2101002-507705	PARKS	1994	5307	128205	26 PA PICKUP	\$ 45,000.00	31,426.00	Ford F150	Capital Ford	State of Nevada	12/3/2020	
24	2101002-507705	PARKS	2002	5319	154688	18 PA PICKUP	\$ 45,000.00	31,426.00	Ford F150	Capital Ford	State of Nevada	12/3/2020	
25	2545047-507775	PARKS	NEW	NEW		PA PARK RANGER	\$ 45,000.00	30,190.47	Ford F150	Capital Ford	State of Nevada	12/3/2020	
PA DUMP TRUCK (CHIPPER)													
26	2101002-507705	PARKS	1995	6015	60,800	25 DUMP)	\$ 75,000.00	63,427.99	Ford F550/Scelzi	Capital Ford	State of Nevada	12/3/2020	
							\$ 280,000.00	\$ 219,322.46					
27	2101002-507705	ALT SENT	1999	926	93902	21 ALT SENT CROWN VICTORIA	\$ 60,000.00	33,872.00	Ford Interceptor	Capital Ford	State of Nevada	12/3/2020	
28	2101002-507705	ALT SENT	2006	2235	130133	14 ALT SENT DURANGO	\$ 60,000.00	33,872.00	Ford Interceptor	Capital Ford	State of Nevada	12/3/2020	
							\$ 120,000.00	\$ 67,744.00					
29	2101002-507705	SHERIFF	2010	11	139874	10 SO TAHOE	\$ 65,000.00	40,521.16	Chevy Tahoe	Michael Hohl Chevy	State of Nevada	12/3/2020	

	Fund	Dept.	Year	Equip #	Mileage	Years of Service	Type of Unit	FY 20/21 Budget	Vehicle cost	Replacement Vehicle Make and Model	Vendor	Contract/PO	BOS Date
30	2101002-507705	SHERIFF	2012	214	142295	8	SO TAHOE	\$ 65,000.00	40,521.16	Chevy Tahoe	Michael Hohl Chevy	State of Nevada	12/3/2020
31	2101002-507705	SHERIFF	2012	216	122727	8	SO TAHOE	\$ 65,000.00	40,521.16	Chevy Tahoe	Michael Hohl Chevy	State of Nevada	12/3/2020
32	2101002-507705	SHERIFF	2012	217	182822	8	SO TAHOE	\$ 65,000.00	40,521.16	Chevy Tahoe	Michael Hohl Chevy	State of Nevada	12/3/2020
33	2101002-507705	SHERIFF	2012	218	137800	8	SO TAHOE	\$ 65,000.00	40,521.16	Chevy Tahoe	Michael Hohl Chevy	State of Nevada	12/3/2020
34	2101002-507705	SHERIFF	2006	616	57481	14	SO HARLEY DAVIDSON	\$ 38,000.00	-	Harley	Battle Born Harley	<i>Has not been purchased</i>	
35	2101002-507705	SHERIFF	2007	722	175,772	13	SO EXPEDITION	\$ 80,000.00	38,880.96	Ford Transit T350	Capital Ford	State of Nevada	12/3/2020
								\$ 443,000.00	\$ 288,266.24				
36	2101002-507705	ASSESSOR	2006	1107	47565	14	AS MALIBU	\$ 35,000.00	29,102.05	Toyota RAV4 Hybrid	Carson Toyota	State of Nevada	12/3/2020
								\$ 35,000.00	\$ 29,102.05				
37	2101002-507705	DA	2001	1228	85138	19	DA LUMINA	\$ 30,000.00	29,102.05	Toyota RAV4 Hybrid	Carson Toyota	State of Nevada	12/3/2020
								\$ 30,000.00	\$ 29,102.05				
38	2101002-507705	HEALTH	2007	1108	52842	13	HE TAURUS	\$ 30,000.00	29,102.05	Toyota RAV4 Hybrid	Carson Toyota	State of Nevada	12/3/2020
								\$ 30,000.00	\$ 29,102.05				
39	2101002-507705	PURCHASIN	2004	2203	94516	16	PU BLAZER	\$ 30,000.00	27,166.02	Toyota Prius Hybrid	Carson Toyota	State of Nevada	12/3/2020
								\$ 30,000.00	\$ 27,166.02				
40	2101002-507705	JV PROBATI	2003	2218	93500	17	JV BLAZER	\$ 35,000.00	28,601.94	Chevy Traverse	Michael Hohl Chevy	State of Nevada	12/3/2020
41	2101002-507705	JV PROBATI	2007	2229	126417	13	JV BLAZER	\$ 35,000.00	28,601.94	Chevy Traverse	Michael Hohl Chevy	State of Nevada	12/3/2020
								\$ 70,000.00	\$ 57,203.88				
42	2101002-507705	BLDG MAIN	2004	4001	54487	16	BM VAN	\$ 35,000.00	33,759.69	Ford Transit	Capital Ford	State of Nevada	12/3/2020
43	2101002-507705	BLDG MAIN	2006	5404	61394	14	BM PICKUP	\$ 55,000.00	47,976.00	Ford F350	Capital Ford	State of Nevada	12/3/2020
								\$ 90,000.00	\$ 81,735.69				
44	DONATION	SHERIFF	NEW	NEW	<b>DONATION</b>		SO TAHOE	\$ 45,464.75	\$ 45,464.75	Chevy Tahoe	Michael Hohl Chevy	State of Nevada	12/3/2020
45	DONATION	FD FUELS	NEW	NEW	<b>DONATION</b>		FD FUELS F350	\$ 65,000.00	\$ 46,259.00	Ford F350	Capital Ford	State of Nevada	12/3/2020
46	DONATION	FD FUELS	NEW	NEW	<b>DONATION</b>		CAT 299D TRACK LOADER	\$ 130,000.00	\$ 113,561.11	Cat 299D	Cashman CAT	Sourcwell	12/3/2020
								\$ 240,464.75	\$ 205,284.86				
								\$ 3,029,604.75	\$ 2,594,450.39	<b>Highlighted vehicles seeking approval 12/3/2020</b>			
									\$ 2,389,165.53				
									\$ 205,284.86				

**LANDFILL**

**CARSON CITY, CITY OF**

ATTN: KAREN C/O CARSON CITY LANDFILL 3505 BUTTI WAY  
 CARSON CITY

CUSTOMER NO.	PROPOSAL NO.	DATE	CONTACT
101645	80565	6/1/2020	RICH HARDCASTLE
PHONE NO.	FAX NO.	EMAIL	
(775) 283-7436		rhardcastle@carson.org	
MODEL	MAKE	SERIAL NO.	
966M	AA	0KJP00826	
UNIT NO.	HOURS	WO NO.	P.O. NO.
8204	11040		
Note			
CPT + PT HOSES COST IS BASED ON THE EXPECTED PARTS AND LABOR UPDATES FOR 4TH QTR 2021: IF MACHINE IS BROUGHT IN 1ST QTR 2021 THE EXPECTED PARTS AND LABOR COST WOULD BE LESS.			

**SEGMENT: 01** REMOVE & INSTALL RADIATOR  
 NOTES:  
 FOR ACCESS PULL HOOD, FRONT BELLY PAN, REMOVE HARD NOSE. REMOVE RADIATOR, REPLACE HOSES, SEALS AND GASKETS IF APPLICABLE, NEW COOLANT.

<b>Parts</b>	<b>Total Estimated Parts:</b>	2,695.00
<b>Labor</b>	<b>Total Flat Rate Labor:</b>	876.00
<b>Labor Summary</b>		
<b>Misc</b>	<b>Total Time and Material Misc:</b>	0.00
	<b>Segment 01 Total:</b>	3,571.00

**SEGMENT: 02** RECONDITION RADIATOR & OIL COOLER  
 NOTES:  
 RECONDITION RADIATOR, CONDENSER AND COOLERS:  
 VENDOR IS TO DISASSEMBLE, CLEAN (RODDING), MINOR REPAIRS AND ASSEMBLE.

<b>Parts</b>	<b>Total Estimated Parts:</b>	2,160.00
<b>Labor</b>		

<b>Labor Summary</b>	<b>Total Flat Rate Labor:</b>	2,336.00
<b>Misc</b>	<b>Total Estimated Misc:</b>	6,300.00
	<b>Segment 02 Total:</b>	10,796.00

---

**SEGMENT: 03** REMOVE & INSTALL CLEAN EMISSIONS MODULE  
NOTES:  
REMOVE AND INSTALL CLEAN EMISSIONS MODULE

<b>Parts</b>	<b>Total Estimated Parts:</b>	1,195.00
<b>Labor</b>	<b>Total Flat Rate Labor:</b>	1,752.00
<b>Labor Summary</b>	<b>Total Estimated Misc:</b>	0.00
<b>Misc</b>	<b>Segment 03 Total:</b>	2,947.00

---

**SEGMENT: 04** REPLACE WITH NEW CLEAN EMISSIONS MODULE  
NOTES:  
REPLACE W/ NEW CLEAN EMISSIONS MODULE:  
COST TO RECONDIITON VS. REPLACE W/ NEW

<b>Parts</b>	<b>Total Estimated Parts:</b>	26,114.00
<b>Labor</b>	<b>Total Flat Rate Labor:</b>	146.00
<b>Labor Summary</b>	<b>Total Estimated Misc:</b>	0.00
<b>Misc</b>	<b>Segment 04 Total:</b>	26,260.00

---

**SEGMENT: 05** REMOVE & INSTALL DIESEL EXHAUST FLUID (TNK)  
NOTES:  
REMOVE AND INSTALL DEF TANK ASSEMBLY FOR  
RECONDITION OR REPLACEMENT

<b>Parts</b>	<b>Total Estimated Parts:</b>	216.00
<b>Labor</b>	<b>Total Flat Rate Labor:</b>	876.00

**Labor Summary**

**Misc**

**Total Estimated Misc:** 0.00

**Segment 05 Total:** 1,092.00

---

**SEGMENT: 06** REPLACE WITH NEW DIESEL EXH (DEF) MODULE (TNK)  
NOTES:  
REPLACE W/ NEW DEF TANK VS. RECONDITION TANK

**Parts**

**Total Estimated Parts:** 4,456.00

**Labor**

**Total Flat Rate Labor:** 146.00

**Labor Summary**

**Misc**

**Total Estimated Misc:** 0.00

**Segment 06 Total:** 4,602.00

---

**SEGMENT: 07** REMOVE & INSTALL ENGINE & TRANSMISSION  
NOTES:  
REMOVE AND INSTLL ENGINE AND TRANSMISSION.  
PARTS ARE CONNECTING SEALS AND GASKETS.

**Parts**

**Total Estimated Parts:** 2,391.00

**Labor**

**Total Flat Rate Labor:** 10,512.00

**Labor Summary**

**Misc**

**Total Estimated Misc:** 0.00

**Segment 07 Total:** 12,903.00

---

**SEGMENT: 08** SEPARATE & CONNECT ENGINE & TRANSMISSION  
NOTES:  
REMOVE TRANSMISSION FROM ENGINE:  
INSTALL TRANSMISSION TO ENGINE:

**Parts**

**Total Estimated Parts:** 95.00

**Labor**

**Total Flat Rate Labor:** 876.00

**Labor Summary**



Misc

Total Estimated Misc: 0.00

Segment 08 Total: 971.00

---

**SEGMENT: 09** RO LEVEL 2 RECONDITION ENGINE

NOTES:  
RECONDITION LEVEL 2 ENGINE:  
AFTER DISASSEMBLY OF THE COMPONENT, THE COMPONENT  
WILL BE INSPECTED PER REUSABILITY GUIDELINES AND  
APPROVAL WILL BE REQUIRED FOR ADDITIONAL PARTS AND  
OR MACHINE WORK THAT ARE NOT COVERED UNDER THE  
ORIGINAL SCOPE OF REPAIRS

Parts

Total Estimated Parts: 39,214.00

Labor

Total Flat Rate Labor: 16,330.00

Labor Summary

Misc

Total Estimated Misc: 0.00

Segment 09 Total: 55,544.00

---

**SEGMENT: 10** RO LEVEL 2 RECONDITION TRANSMISSION

NOTES:  
RECONDITION LEVEL 2 TRANSMISSION:  
EXCLUDES: MAOR CASTINGS, SHAFTS, YOKES, PLATES,  
PANELS, HOUSINGS, AND GEARS  
AFTER DISASSEMBLY OF THE COMPONENT, THE COMPONENT  
WILL BE INSPECTED PER REUSABILITY GUIDELINES AND  
APPROVAL WILL BE REQUIRED FOR ADDITIONAL PARTS AND  
OR MACHINE WORK THAT ARE NOT COVERED UNDER THE  
ORIGINAL SCOPE OF REPAIRS

Parts

Total Estimated Parts: 16,500.00

Labor

Total Flat Rate Labor: 9,993.00

Labor Summary

Misc

Total Estimated Misc: 0.00

Segment 10 Total: 26,493.00

---

**SEGMENT: 11** REMOVE/INSTALL, REPLACE DRIVETRAIN OIL LINES

NOTES:  
REMOVE, REPLACE, INSTALL TRANSMISSION OIL COOLER,

TRANSMISSION OIL PUMP (ONLY) AND DRIVETRAIN OIL  
LINES

<b>Parts</b>	<b>Total Estimated Parts:</b>	6,883.00
<b>Labor</b>	<b>Total Flat Rate Labor:</b>	2,336.00
<b>Labor Summary</b>		
<b>Misc</b>	<b>Total Estimated Misc:</b>	0.00
	<b>Segment 11 Total:</b>	9,219.00

---

**SEGMENT: 12** RECONDITION DRIVE SHAFT  
 NOTES:  
 RECONDITION DRIVE LIVE:  
 INCLUDES: BEARINGS, U-JOINTS, AND HARDWARE  
 EXCLUDES: SHAFTS  
 AFTER DISASSEMBLY OF THE COMPONENT, THE COMPONENT  
 WILL BE INSPECTED PER REUSABILITY GUIDELINES AND  
 APPROVAL WILL BE REQUIRED FOR ADDITIONAL PARTS AND  
 OR MACHINE WORK THAT ARE NOT COVERED UNDER THE  
 ORIGINAL SCOPE OF REPAIRS

<b>Parts</b>	<b>Total Estimated Parts:</b>	1,795.00
<b>Labor</b>	<b>Total Flat Rate Labor:</b>	1,168.00
<b>Labor Summary</b>		
<b>Misc</b>	<b>Total Estimated Misc:</b>	0.00
	<b>Segment 12 Total:</b>	2,963.00

---

**SEGMENT: 13** REMOVE & INSTALL AXLE ARRANGEMENT (FR)  
 NOTES:  
 REMOVE AND INSTALL FRONT AXLE ASSEMBLY

<b>Parts</b>	<b>Total Estimated Parts:</b>	2,920.00
<b>Labor</b>	<b>Total Flat Rate Labor:</b>	2,336.00
<b>Labor Summary</b>		
<b>Misc</b>	<b>Total Estimated Misc:</b>	0.00
	<b>Segment 13 Total:</b>	5,256.00

---

**SEGMENT: 14**      RO LEVEL 2 - RECONDITION AXLE ARRANGEMENT (FR)  
 NOTES:  
 RECONDITION LEVEL 2 AXLE ARRANGEMENT:  
 EXCLUDES: MAJOR CASTINGS, GEARS, SHAFTS, PLATES,  
 PISTON, PINION, SPIDER, HOUSINGS, COOLER, AND  
 COVERS.  
 AFTER DISASSEMBLY OF THE COMPONENT, THE COMPONENT  
 WILL BE INSPECTED PER REUSABILITY GUIDELINES AND  
 APPROVAL WILL BE REQUIRED FOR ADDITIONAL PARTS AND  
 OR MACHINE WORK THAT ARE NOT COVERED UNDER THE  
 ORIGINAL SCOPE OF REPAIRS

<b>Parts</b>	<b>Total Estimated Parts:</b>	35,494.00
<b>Labor</b>	<b>Total Flat Rate Labor:</b>	6,882.00
<b>Labor Summary</b>		
<b>Misc</b>	<b>Total Estimated Misc:</b>	0.00
	<b>Segment 14 Total:</b>	42,376.00

---

**SEGMENT: 15**      REMOVE & INSTALL AXLE ARRANGEMENT (RE)  
 NOTES:  
 REMOVE AND INSTALL REAR AXLE ASSEMBLY

<b>Parts</b>	<b>Total Estimated Parts:</b>	2,920.00
<b>Labor</b>	<b>Total Flat Rate Labor:</b>	2,920.00
<b>Labor Summary</b>		
<b>Misc</b>	<b>Total Estimated Misc:</b>	0.00
	<b>Segment 15 Total:</b>	5,840.00

---

**SEGMENT: 16**      RO LEVEL 2 - RECONDITION AXLE ARRANGEMENT (RE)  
 NOTES:  
 RECONDITION LEVEL 2 AXLE ARRANGEMENT:  
 EXCLUDES: MAJOR CASTINGS, GEARS, SHAFTS, PLATES,  
 PISTON, PINION, SPIDER, HOUSINGS, COOLER, AND  
 COVERS.  
 AFTER DISASSEMBLY OF THE COMPONENT, THE COMPONENT  
 WILL BE INSPECTED PER REUSABILITY GUIDELINES AND  
 APPROVAL WILL BE REQUIRED FOR ADDITIONAL PARTS AND  
 OR MACHINE WORK THAT ARE NOT COVERED UNDER THE  
 ORIGINAL SCOPE OF REPAIRS

**Parts**

	<b>Total Estimated Parts:</b>	35,330.00
<b>Labor</b>		
	<b>Total Flat Rate Labor:</b>	7,466.00
<b>Labor Summary</b>		
<b>Misc</b>		
	<b>Total Estimated Misc:</b>	0.00
	<b>Segment 16 Total:</b>	42,796.00

---

**SEGMENT: 17** REMOVE, RECON, INSTALL DIFFERENTIAL LOCK (FR)  
NOTES:  
REMOVE AND INSTALL DIFFERENTIAL LOCK CONTROL:  
VALVE AND SWITCH  
INCLUDES: VALVE, SWITCH, AND HOSES

<b>Parts</b>	<b>Total Estimated Parts:</b>	1,630.00
<b>Labor</b>		
	<b>Total Flat Rate Labor:</b>	876.00
<b>Labor Summary</b>		
<b>Misc</b>		
	<b>Total Estimated Misc:</b>	0.00
	<b>Segment 17 Total:</b>	2,506.00

---

**SEGMENT: 18** REMOVE, RECON, INSTALL BRAKE OIL COOLER  
NOTES:  
RECONDITION AXLE OIL COOLER (EXTERNAL MOUNTED).  
INCLUDES: HOSES, MANIFOLD, AND HOSE SEALS.

<b>Parts</b>	<b>Total Estimated Parts:</b>	3,793.00
<b>Labor</b>		
	<b>Total Flat Rate Labor:</b>	5,256.00
<b>Labor Summary</b>		
<b>Misc</b>		
	<b>Total Estimated Misc:</b>	0.00
	<b>Segment 18 Total:</b>	9,049.00

---

**SEGMENT: 19** REMOVE/INSTALL, REPLACE GEAR PUMP & MOTOR (AOC)  
NOTES:  
REMOVE, REPLACE, INSTALL AXLE OIL COOLER PUMP AND  
MOTOR ASSEMBLY

**Parts**

	<b>Total Estimated Parts:</b>	2,478.00
<b>Labor</b>		
	<b>Total Flat Rate Labor:</b>	584.00
<b>Labor Summary</b>		
<b>Misc</b>		
	<b>Total Estimated Misc:</b>	0.00
	<b>Segment 19 Total:</b>	3,062.00

---

**SEGMENT: 20** REMOVE/INSTALL, REPLACE HYDRAULIC FAN PUMP  
NOTES:  
REMOVE, REPLACE, AND INSTALL BRAKE AND HYDRAULIC FAN PUMP.  
RECOMMENDED SINCE REPLACEMENT OF THE FAN DRIVE MOTOR AND RELATED COMPONENTS ARE BEING REPLACED

<b>Parts</b>	<b>Total Estimated Parts:</b>	2,202.00
<b>Labor</b>		
	<b>Total Flat Rate Labor:</b>	584.00
<b>Labor Summary</b>		
<b>Misc</b>		
	<b>Total Estimated Misc:</b>	0.00
	<b>Segment 20 Total:</b>	2,786.00

---

**SEGMENT: 21** REMOVE/INSTALL, REPLACE HYDRAULIC HOSES/LINES  
NOTES:  
REMOVE, REPLACE, AND INSTALL THE FOLLOWING HOSES: HYDRAULIC SYSTEM, HYDRAULIC FAN, STEERING SYSTEM - (CHASSIS), HYDRAULIC COOLER, STEERING, IMPLEMENT (CYLINDERS), "SOFT MOUNTS"AND RIDE CONTROL HOSES ONLY:  
EXCLUDES: TUBES (METAL LINES), MOUNTS (STEEL), NON-LOCKING HARDWARE, ACCUMULATORS, ANY AND ALL VALVES.

<b>Parts</b>	<b>Total Estimated Parts:</b>	16,838.00
<b>Labor</b>		
	<b>Total Flat Rate Labor:</b>	14,016.00
<b>Labor Summary</b>		
<b>Misc</b>		
	<b>Total Estimated Misc:</b>	0.00
	<b>Segment 21 Total:</b>	30,854.00

---

**SEGMENT: 22** REMOVE/INSTALL, REPLACE IMPLEMENT PUMP  
 NOTES:  
 REPLACE ALL PUMPS: STEERING, FAN, BRAKE, AND  
 IMPLEMENT:  
 EXCLUDES: GEARS, TUBES (HYDRAULIC), TANK, AND  
 NON-LOCKING FASTENERS.

<b>Parts</b>	<b>Total Estimated Parts:</b>	35,795.00
<b>Labor</b>	<b>Total Flat Rate Labor:</b>	1,752.00
<b>Labor Summary</b>		
<b>Misc</b>	<b>Total Estimated Misc:</b>	0.00
	<b>Segment 22 Total:</b>	<b>37,547.00</b>

---

**SEGMENT: 23** RECONDITION HITCH  
 NOTES:  
 RECONDITION HITCH:  
 INCLUDES: SEPARATE AND CONNECT, WELD BORE LABOR,  
 BEARINGS, SHIMS, AND PINS

<b>Parts</b>	<b>Total Estimated Parts:</b>	4,001.00
<b>Labor</b>	<b>Total Flat Rate Labor:</b>	10,512.00
<b>Labor Summary</b>		
<b>Misc</b>	<b>Total Estimated Misc:</b>	1,051.00
	<b>Segment 23 Total:</b>	<b>15,564.00</b>

---

**SEGMENT: 25** REMOVE & INSTALL LIFT ARM  
 NOTES:

<b>Parts</b>	<b>Total Estimated Parts:</b>	10,000.00
<b>Labor</b>	<b>Total Estimated Labor:</b>	5,112.00
<b>Labor Summary</b>		
<b>Misc</b>	<b>Total Estimated Misc:</b>	0.00
	<b>Segment 25 Total:</b>	<b>15,112.00</b>

---

**SEGMENT 22**

SEGMENT: 88      PAINT MACHINE  
NOTES:  
PAINT AND DECAL MACHINE

Parts	Total Estimated Parts:	1,829.00
Labor	Total Flat Rate Labor:	18,104.00
Labor Summary		
Misc	Total Estimated Misc:	1,811.00
	<b>Segment 88 Total:</b>	<b>21,744.00</b>

---

SEGMENT: 89      TRANSPORT MACHINE  
NOTES:

Parts	Total Estimated Parts:	0.00
Labor	Total Estimated Labor:	0.00
Labor Summary		
Misc	Total Estimated Misc:	1,600.00
	<b>Segment 89 Total:</b>	<b>1,600.00</b>

---

	<b>Total Segments:</b>	<b>393,453.00</b>
<b>SUB TOTAL (BEFORE TAXES)    N a</b>		<b>393,453.00</b>

---

MONROE TRUCK EQUIPMENT, INC  
1051 WEST 7TH. STREET  
MONROE WI 53566  
608-328-8127 FAX 608-328-4278

**STREET MAINT.  
DUMP-BODY**

CUSTOMER: 1952500  
Ship to: CARSON CITY, CITY OF  
3303 BUTTI WAY, BLDG 2

CARSON CITY NV 89701

QUOTE # DK060120  
DATE: 06/01/20  
CUST PO #  
TERMS: NET 30  
SALES REP: 561  
QUOTED BY: Dennis

WE ARE PLEASED TO QUOTE FOR ACCEPTANCE WITHIN 90 DAYS FROM THE DATE OF QUOTE  
PRICES & TERMS IN ACCORDANCE WITH SPECIFICATIONS DESCRIBED IN QUOTE. STATE AND  
FEDERAL TAXES WILL BE ADDED WHERE APPLICABLE.

10' CRYSTEEL SELECT DUMP BODY  
- 7-YD  
- 1/4" AR400 145,000 PSI YIELD FLOOR AND TAILGATE  
- 62" FRONT HEIGHT, 10GA. A1011 STEEL  
- 34" SIDE HEIGHT, 10GA. A1011 STEEL  
- 42" REAR HEIGHT  
- 8" FORMED TUBULAR CROSSMEMBERLESS UNDERSTRUCTURE  
- 84" ID 96" OD WIDTH  
- 3 PANEL TAILGATE  
- 1 1/2" OFFSET TAILGATE HINGE PLATE  
- AIR TAILGATE RELEASE  
- SLOPING FULLY BOXED TOP RAILS WITH 3" WIDE BOARD POCKETS  
- L.E.D. LIGHTING UPGRADE  
- FMVSS108 LIGHTS AND REFLECTORS  
- GRAB HANDLE AND STEP  
- 24" CAB SHIELD 100% WELDED  
- BACK-UP ALARM  
- UNDERCOATED  
- RUBBER REAR FLAPS  
- SANDBLASTED, PRIMED AND PAINTED ONE COLOR  
- INSTALLED

MAILHOT M90-4.5-3 TELESCOPIC HOIST

- NITRATED CYLINDER  
- REAR HINGE  
- BODY UP LIGHT  
- BODY PROPS  
- INSTALLED

MC7092; FOLD FLAT LIFT ARM QUICK HITCH; TRUCK PORTION

- POSITIVE TWO POINT LATCH SYSTEM  
- FOLD FLAT ADJUSTABLE LIFT ARM  
- POWDER COAT BLACK  
- SIDE PLATE KIT  
- HOOD MOUNTED BRACKET KIT; PLOW LIGHT; NAVISTAR-WORKSTAR  
- ABL LED PLOW LIGHTS WITH HEATED LENS

\*\*\* CONTINUED NEXT PAGE \*\*\*



MONROE FULL MOLDBOARD TRIP REVERSIBLE PLOW

- 10 GAUGE ROLL FORMED STRAIGHT MOLDBOARD
- (6) 1/2" X 4" TAPERED, ONE-PIECE FLAME CUT RIBS
- 2" X 3" X 3/8" TOP MOLDBOARD ANGLE
- 4" X 4" X 3/4" BOTTOM MOLDBOARD ANGLE
- HORIZONTAL MOLDBOARD BRACE ANGLES
- 5/8" X 8" ONE-PIECE TOP PUNCH CUTTING EDGE
- DUAL COMPRESSION TRIP SPRING ASSEMBLIES
- 4" X 4" X 3/8" CROSS-TUBE SUPPORT
- 3-1/2" X 3-1/2" X 1/2" SEMI-CIRCLE
- (2) 3" X 10" DOUBLE ACTING POWER REVERSE CYLINDERS WITH CUSHION VALVE
- BUILT-IN MONROE LEVEL LIFT ASSEMBLY
- SKID SHOES
- PAIR OF WRAP AROUND CURB GUARDS
- SCREW ADJUSTABLE PARKING JACK
- 36" FLEXIBLE ORANGE PLOW MARKERS
- 12" RUBBER SNOW DEFLECTOR
- MOLDBOARD AND PUSHFRAME 100% CONTINUOUSLY WELDED
- MOLDBOARD POWDER COATED ORANGE
- PUSH FRAME POWDER COATED BLACK

MONROE 8' MID-MOUNT EXTENDABLE PATROL WING WITH OPTIONS

- 10 GA X 24" MOLDBOARD
- CROSS TUBE WITH MOUNTING HARDWARE
- DOUBLE ACTING CYLINDER FOR EXTENSION
- SINGLE ACTING CYLINDER FOR HEEL
- QUICK DETACH ON WING MOLDBOARD
- UNIVERSAL LEFT OR RIGHT-HAND MOUNT
- NON-TRIP MOLDBOARD
- MOLDBOARD POWDER COATED ORANGE
- HARDWARE POWDER COATED BLACK
- CURB GUARD
- HYDRAULIC LOCK KIT; VALVE, WING LOCK (2) 3/4" ORB
- WPLOW1A LED WING STROBE MOUNTED ON WING
- LED WING WORK LIGHT MOUNTED TO RIGHT SIDE/BOTTOM CAB

MONROE MSV-120-84-56; HD MCV; 10' X 84"; 56" SIDES 6.5 YD; WITH OPTIONS

- 45 DEGREE SLOPED SIDES
- 10 GA. HOPPER SHELL
- CONTINUOUSLY WELDED ASSEMBLY
- 8 TOOTH SPROCKETS
- 2" SPRING LOADED IDLER SHAFT WITH 4 BOLT RELUBEABLE BEARINGS
- 2" DRIVE SHAFT
- FRONT & REAR WIPERS
- 3/16" BOLT-IN CHAIN SHIELDS
- 50:1 RATIO GEAR BOX
- SELF-LOCKING SCREW JACK
- METERING GATE CONTROLS
- TIP-UP SPINNER CHUTE
- 3/8" TOP SCREENS WITH 6" H BEAM
- POWDER COATED ORANGE
- INVERTED V
- LEG Kit Skid, LADDER & LIGHT KITS
- CHAIN OILER & GREASE EXTENSION KITS
- INSTALLED

CLOSED LOOP HYD PLUMBING KIT; 7 GPM PUMP; NO VALVE; DICKY JOHN/MPS FLOW METER

- (2) 100 GAL POLY TANK WITH MILD STEEL MOUNTING HARDWARE; LARGE V-BOX
- BULK FILL KIT; - FLUSHER KIT; - NOZZLE KIT; (3) 2 GPM NOZZLES
- CROSS-OVER KIT; V-BOX

- MTE CUSTOM HYDRAULICS - LOADSENSE, PTO MOUNT, ELECTRIC; INSTL
- TXV92 PUMP, PTO MOUNT, RH ROT., DIN SPLINE; INSTL
- 5.6 CUBIC INCH 92CC LOAD SENSE
- 48 GPM FLOW @ 2000 RPM
- DIN ISO 14 MOUNT
- PTO, HOT-SHIFT, ROTATABLE FLANGE; NEW WORLD TRANSMISSON; INSTL
- TANK, 30 GAL. LOW-PRO, FRAME MOUNT, W/FILTR., MILD STEEL, (SCRPR APP.); INSTL
- FORCE ADD-A-FOLD VALVE/ENCLOSURE, FRAME MOUNT, MILD STEEL; INSTL
- BLADE SAVER VALVE
- MANIFOLD, PINTLE PLATE MOUNTED; SPREADER
- 4 BANK MANIFOLD PLATE FOR WING; INCLUDES COUPLERS

- FORCE IGRIP SINGLE JOYSTICK WITH 6100 CLOSED LOOP SPREADER CONTROL
- IGRIP SINGLE JOYSTICK HAS X, Y, Z AXIS MOVEMENT WITH CUSTOM ARMREST MOUNTING
- 5 PROGRAMMABLE LED BACKLIT SWITCHES
- 3 CONTACTLESS TACTILE MODE SELECTION ZONES
- SIDE SWITCH CLUSTERS FOR STANDBY/BLAST AND RATE CHANGES 6100 CLOSED LOOP SPREADER CONTROL
- TIMED OR MOMENTARY BLAST SWITCH
- ELECTRIC OR HYD. LIQUID CAPABLE
- ON SCREEN INDICATOR FOR BODY UP, LOW OIL, HOT OIL
- MOUNTED WITHIN EASY REACH OF OPERATOR

- PINTLE MOUNT; 1" PLATE WITH 3/4" D-RINGS
- PREMIER 2200 PINTLE HOOK W/O AIR
- 7-WAY CONNECTOR, ROUND SOCKET, FLAT PIN, RV STYLE
- RELOCATE OEM ABS PLUG IN PINTLE PLATE
- GLADHANDS INSTALLED IN REAR PINTLE PLATE

- LIGHTING PACKAGE
- WHELEN, L.E.D. SELF CONTAINED 2 LIGHT STROBE SYSTEM - REARBODY POST
- WHELEN, L.E.D. SELF CONTAINED 2 LIGHT STROBE SYSTEM - CABSHIELD FORWARD FACING
- WHELEN, L.E.D. SELF CONTAINED 2 LIGHT STROBE SYSTEM - CABSHIELD SIDE FACING
- TIR3 STROBES ON FRONT HOOD

FAB WHEEL CHOCK HOLDERS & WHEEL CHOCKS

- R CONCEPTS, FRAME MOUNT STEEL TOOL BOX, 24" X 18" X 18"; 96 LBS. \*
- 13 GA. STEEL CONSTRUCTION
- DOUBLE PANEL DOOR
- RUBBER DOOR SEAL
- STAINLESS STEEL "T" HANDLE WITH THREE POINT LATCH
- ADJUSTABLE HINGE
- POWDER COATED BLACK
- INSTALLED

DELIVERY BY DRIVING

FREIGHT FOR PLOW & WING

TOTAL QUOTE ----- 124,179.00

Quote Accepted By: X \_\_\_\_\_ Date: \_\_\_\_\_ P.O.: \_\_\_\_\_  
 Submitted By: \_\_\_Dennis Koering\_\_\_ for MONROE TRUCK EQUIPMENT  
 Make/Model: \_\_\_\_\_ W.B. \_\_\_\_\_ C.A. \_\_\_\_\_ Engine: \_\_\_\_\_  
 Transmission: \_\_\_\_\_ A/C: Y / N Brakes: Air / Hyd.  
 Chassis Color: \_\_\_\_\_ Paint Code: \_\_\_\_\_ Stock #: \_\_\_\_\_  
 Chassis ETA: \_\_\_\_\_  
 VIN #: \_\_\_\_\_



**STREET MAINT.  
 5 YARD DUMP  
 SANDER/PLOW-TRUCK**

International Trucks is pleased to provide you with this proposal compliant with all terms of the Sourcwell Vehicles and Chassis Contract #081716-NVS awarded to Navistar, Inc for new International Truck. If you have any questions regarding enrollment in Sourcwell or detailed contract terms and conditions, please see your International Truck sales representative.

PROPOSAL PREPARED FOR:		PROPOSAL PREPARED BY:	
Sourcewell Member:	Carson City	Silver State International	
Contact:	Rich Hardcastle	Bo Burgarello	
Address:	3505 Butti Way	2255 Larkin Circle	
City/State/Zip:	Carson City NV. 89701	Sparks NV. 89431	
Phone:	(775)400-7683	(775)691-9972	
Email:	<a href="mailto:rhardcastle@carson.org">rhardcastle@carson.org</a>	<a href="mailto:bo@ssitrucks.com">bo@ssitrucks.com</a>	

Proposal Number	4060
Date	6/18/2020
Quantity of this Specification	1
Single Sourcewell Transaction Total Volume	1

Chassis		
New 2021 International HV513 4x2 Chassis		\$ 210,910.00
Base Chassis List	\$ 172,454.00	
Options List	\$ 38,456.00	
Sourcewell Contract Discount	\$ 0.49	\$ (102,502.26)
Volume Incentive		\$ -
Net Sourcewell Chassis Price		\$ 108,407.74
Sourcewell Partner Body		
		\$ -
		\$ -
		\$ -
		\$ -
Non-Sourcewell Dealer Supplied Body		
		\$ -
		\$ -
		\$ -
		\$ -
Handling Fee	5.00%	\$ -
Additional Post Build Work		
DOT and Detail		\$ 2,000.00
		\$ -
		\$ -
		\$ -
		\$ -
		\$ -
Handling Fee	5.00%	\$ 100.00
Service Contracts		
		\$ -
		\$ -
		\$ -
Additional Freight		
		\$ -
		\$ -
Additional Floorplan		
		\$ -
		\$ -
Additional Fees & Taxes		
		\$ -
		\$ -
<b>Total Sourcewell Customer Price FOB Carson City</b>		<b>\$ 110,507.74</b>

Terms:

**Prepared For:**  
 CARSON CITY PURCHASING  
 Rich Hardcastle  
 Vehicle Maintenance  
 Carson City, NV 89701-  
 (775)887 - 2342  
 Reference ID: N/A

**Presented By:**  
 SILVER STATE INTL  
 Bo Burgarello  
 2255 LARKIN CIRCLE  
 SPARKS NV 89431 -  
 (775)685-6000

Thank you for the opportunity to provide you with the following quotation on a new International truck. I am sure the following detailed specification will meet your operational requirements, and I look forward to serving your business needs.

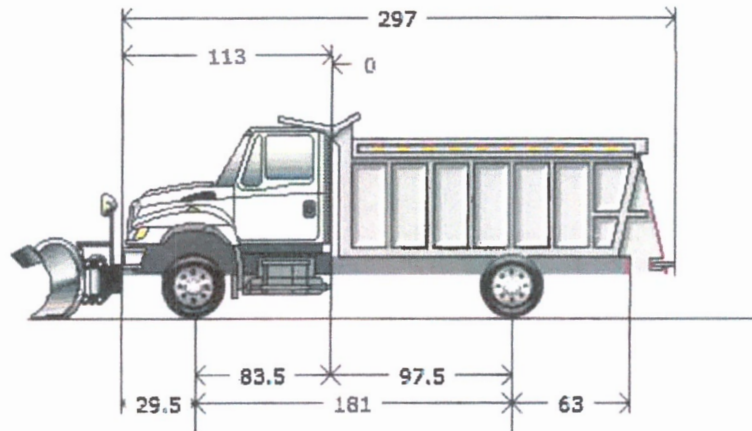

**Model Profile**  
**2021 HV513 SFA (HV513)**

<b>AXLE CONFIG:</b>	4X2
<b>APPLICATION:</b>	Front Plow and Wing with Spreader
<b>MISSION:</b>	Requested GVWR: 66000. Calc. GVWR: 39000 Calc. Start / Grade Ability: 24.39% / 2.61% @ 55 MPH Calc. Geared Speed: 77.7 MPH
<b>DIMENSION:</b>	Wheelbase: 181.00, CA: 97.50, Axle to Frame: 63.00
<b>ENGINE, DIESEL:</b>	{International A26} EPA 2017, 410HP @ 1700 RPM, 1450 lb-ft Torque @ 1000 RPM, 2100 RPM Governed Speed, 410 Peak HP (Max)
<b>TRANSMISSION, AUTOMATIC:</b>	{Allison 4500 RDS} 5th Generation Controls, Wide Ratio, 6-Speed with Double Overdrive, with PTO Provision, Less Retarder, Includes Oil Level Sensor, On/Off Highway
<b>CLUTCH:</b>	Omit Item (Clutch & Control)
<b>AXLE, FRONT NON-DRIVING:</b>	{Meritor MFS-16-143A} Wide Track, I-Beam Type, 16,000-lb Capacity
<b>AXLE, REAR, SINGLE:</b>	{Meritor RS-23-160} Single Reduction, 23,000-lb Capacity, Driver Controlled Locking Differential, 200 Wheel Ends Gear Ratio: 4.89
<b>CAB:</b>	Conventional, Day Cab
<b>TIRE, FRONT:</b>	(2) 315/80R22.5 Load Range L HAU 3 WT (CONTINENTAL), 480 rev/mile, 68 MPH, All-Position
<b>TIRE, REAR:</b>	(5) 11R22.5 Load Range H HDW2 (CONTINENTAL), 495 rev/mile, 75 MPH, Drive
<b>SUSPENSION, REAR, SINGLE:</b>	23,500-lb Capacity, Vari-Rate Springs
<b>FRAME REINFORCEMENT:</b>	Full Outer C-Channel, Heat Treated Alloy Steel (120,000 PSI Yield), 10.813" x 3.892" x 0.312" (274.6mm x 98.8mm x 7.9mm), 480.0" (12192mm) OAL
<b>PAINT:</b>	Cab schematic 100WM Location 1: 9219, Winter White (Std) Chassis schematic N/A



**STREET MAINT.  
PUP 6-YARD**



Awarded Contract

Contract # 091219-CBR

Quote #: 1489

Reseller: CURBTENDER  
SOURCEWELL

Reseller Phone: 319-266-1721

Created By: Ben Stone

Ship-to Address:

City of Carson City  
Rich Hardcastle  
3488, 3303 Butti Way # 9  
Carson, City 89701

Customer: City of Carson City

Customer Phone:

Customer Fax:

Email:

Bill-to Address:

City of Carson City  
Rich Hardcastle  
3488, 3303 Butti Way # 9  
Carson, City 89701

Item	Item Description	Qty	Price	Total
PUP (SL) - 09.19				
PU06	PUP, 6 YARD BODY	1	\$35,529	\$35,529
CM01-PU	Truck Mounted	1	\$0	\$0
SM01-PU	Factory Installation	1	\$4,350	\$4,350
CM04-PU	Gas	1	\$0	\$0
CP01-PU	Pump, PTO, Hotshift	1	\$0	\$0
ST01-PU	Curbside Tipper Prep	1	\$280	\$280
RT18-QT	No Cart Tipper	1	\$0	\$0
CL01-QT	LED Stop/Tail/Turn/Reverse Lighting (Std)	1	\$0	\$0
SL01-PU	LED Dual Hopper Work Lights	1	\$350	\$350
SL08-PU	LED Rear Strobe, Single, High Profile Center Mount	1	\$370	\$370
CL03-PU	LED Dual Rear Oval Alternating	1	\$370	\$370
CS01-PU	Fire Extinguisher 10 LBS on Body	1	\$387	\$387
CS12-PU	Curbtender Camera System W/ 5" Monitor	1	\$0	\$0
SS03-PU	Rear Back-up Camera	1	\$0	\$0
CA02-PU	Weld Seam Sealer	1	\$1,630	\$1,630
CA04-PU	Performance White Paint	1	\$0	\$0
CD02-PU	Cooperative Purchase	1	\$0	\$0
CD03-PU	Sourcewell Discount	1	(\$1,600)	(\$1,600)
SW04-PU	Sourcewell Warranty, 2 Year Body Standard	1	\$0	\$0
SW08-PU	Sourcewell Warranty, 2 Year Cylinder Standard	1	\$0	\$0
CD05-PU	Repeat Customer Discount	1	(\$600)	(\$600)
	<b>Dual LED Front oval flashers</b>	<b>1</b>	<b>\$370</b>	<b>\$370</b>
	<b>Ford F450 Gas 4x4</b>	<b>1</b>	<b>\$47,367</b>	<b>\$47,367</b>

Freight: \$4,200

**Total: \$93,003**

This quote is valid until: 12/9/2020

QUOTE IS NOT CONSIDERED FIRM UNTIL IT HAS BEEN SUBMITTED FOR ENGINEERING REVIEW AND APPROVED BY CURBTENDER.

Siddons Martin Emergency Group, LLC  
 3500 Shelby Lane  
 Denton, Texas 76207  
 GDN P115891  
 TXDOT MVD No. A115890  
 EIN 27-4333590



Contract:FS12-19

**FIRE PIERCE PUMPER**

November 19, 2020

**CARSON CITY FIRE DEPARTMENT**  
**777 S STEWART ST**  
**CARSON CITY, NV 89701**

**Proposal for Carson City Pumper #3**

Siddons-Martin Emergency Group, LLC is pleased to provide the following proposal to **CARSON CITY FIRE DEPARTMENT**. The unit will comply with all specifications attached. Total price includes delivery to **CARSON CITY FIRE DEPARTMENT** and training on operation and use of the apparatus.

Description	Amount
<b>1) Unit price - \$703,688.21</b>	
Price guaranteed for 60 days. Delivery within 10.5-11.5 months of order date. A warranty term of 12 months is included.	
Vehicle Price	\$703,688.21
Chassis Prepay Discount	(\$11,912.11)
Aerial Prepay Discount	\$0.00
Full Prepay Discount	(\$9,020.46)
Trade-In	\$0.00
Other Loose Equipment	\$0.00
Other Trip Amount	\$0.00
Other Misc. Amount	\$0.00
<b>Sub Total</b>	<b>\$682,755.64</b>
Contract Amount	\$2,000.00
<b>Final Sales Price</b>	<b>\$684,755.64</b>

**Additional.** Includes travel to final inspection for three Carson City personnel.

**Taxes.** Taxes are not included in this proposal. In the event that the purchasing organization is not exempt from sales tax or any other applicable taxes and/or the proposed apparatus does not qualify for exempt status, it is the duty of the purchasing organization to pay any and all taxes due. Balance of sale price is due upon acceptance of the apparatus at the factory.

**Late Fee.** A late fee of .033% of the sale price will be charged per day for overdue payments beginning ten (10) days after the payment is due for the first 30 days. The late fee increases to .044% per day after the first 30 days until the payment is received. In the event a prepayment is received after the due date, the discount will be reduced by the same percentages above, increasing the overall cost of the apparatus.

**Cancellation.** In the event this proposal is accepted, and a purchase order is issued then cancelled or terminated by Customer before completion, Siddons-Martin Emergency Group may charge a cancellation fee. The following charge schedule based on costs incurred and may be applied:

- (A) 10% of the Purchase Price after order is accepted and entered by Manufacturer;
- (B) 20% of the Purchase Price after completion of the approval drawings;
- (C) 30% of the Purchase Price upon any material requisition by Manufacturer.

The cancellation fee will increase accordingly as costs are incurred as the order progresses through engineering and into manufacturing. Siddons-Martin Emergency Group endeavors to mitigate any such costs through the sale of such product to another purchaser; however, the customer shall remain liable for the difference between the purchase price and, if applicable, the sale price obtained by Siddons-Martin Emergency Group upon sale of the product to another purchaser, plus any costs incurred by Siddons-Martin Emergency Group to conduct such sale.

**Acceptance.** In an effort to ensure the above stated terms and conditions are understood and adhered to, Siddons-Martin Emergency Group, LLC requires an authorized individual from the purchasing organization to sign and date this proposal and include it with any purchase order. Upon signing this proposal, the terms and conditions stated herein will be considered binding and accepted by the Customer. The terms and acceptance of this proposal will be governed by the laws of the State of Texas. No additional terms or conditions will be binding upon Siddons-Martin Emergency Group, LLC unless agreed to in writing and signed by a duly authorized officer of Siddons-Martin Emergency Group, LLC

Sincerely,

**Thom Kowatch**  
Siddons-Martin Emergency Group, LLC

I, \_\_\_\_\_, the authorized representative of **CARSON CITY FIRE DEPARTMENT**, agree to all of the terms of this proposal and the specifications attached hereto and this proposal will be binding upon **CARSON CITY FIRE DEPARTMENT**.

\_\_\_\_\_  
Signature & Date



## Michael Hohl Motor Company

Jon L. Blakely | 775-378-2279 | jon.blakely@michaelhohl.com

**WATER**

# Carson City Public Works

Prepared For: Rich Hardcastle

775-283-7436

RHardcastle@carson.org

[Fleet] 2021 Chevrolet Silverado 1500 (CK10753) 4WD Double Cab 147" Work Truck



Please let me know if there are any changes needed to this quote.

Thanks

JB





# Michael Hohl Motor Company

Jon L. Blakely | 775-378-2279 | jon.blakely@michaelhohl.com

[Fleet] 2021 Chevrolet Silverado 1500 (CK10753) 4WD Double Cab 147" Work Truck (✔ Complete)

## Quote Worksheet

	<b>MSRP</b>
Base Price	\$35,800.00
Dest Charge	\$1,595.00
Total Options	\$300.00
<b>Subtotal</b>	<b>\$37,695.00</b>
State Bid Asst	(\$10,100.00)
<b>Subtotal Pre-Tax Adjustments</b>	<b>(\$10,100.00)</b>
Less Customer Discount	(\$1,251.76)
<b>Subtotal Discount</b>	<b>(\$1,251.76)</b>
Trade-In	\$0.00
<b>Subtotal Trade-In</b>	<b>\$0.00</b>
<b>Taxable Price</b>	<b>\$26,343.24</b>
Sales Tax	\$0.00
<b>Subtotal Taxes</b>	<b>\$0.00</b>
DMV 30 Day	\$28.75
<b>Subtotal Post-Tax Adjustments</b>	<b>\$28.75</b>
<b>Total Sales Price</b>	<b>\$26,371.99</b>

### Comments:

Please sign and return to jon.blakely@michael.hohl.com

Thanks You for the opportunity

\_\_\_\_\_  
Dealer Signature / Date

\_\_\_\_\_  
Customer Signature / Date

This document contains information considered Confidential between GM and its Clients uniquely. The information provided is not intended for public disclosure. Prices, specifications, and availability are subject to change without notice, and do not include certain fees, taxes and charges that may be required by law or vary by manufacturer or region. Performance figures are guidelines only, and actual performance may vary. Photos may not represent actual vehicles or exact configurations. Content based on report preparer's input is subject to the accuracy of the input provided.

Data Version: 11835. Data Updated: Sep 9, 2020 10:54:00 PM PDT.

REPLACES  
5523

WATER

---

2020 F-250 4x4 SD Super Cab 8' box 164" WB SRW XL (X2B)

Price Level: 40

---



### Client Proposal

Prepared by:  
TIMOTHY SMITH  
Office: 775-882-5353  
Quote ID: 62420  
Date: 06/24/2020





Prepared by: TIMOTHY SMITH  
06/24/2020

Capital Ford | 3660 South Carson Street Carson City Nevada | 897015579

## 2020 F-250 4x4 SD Super Cab 8' box 164" WB SRW XL (X2B)

Price Level: 40 | Quote ID: 62420

### Pricing Summary - Single Vehicle

**MSRP**

#### Vehicle Pricing

Base Vehicle Price	\$39,370.00
Options & Colors	\$915.00
Upfitting	\$0.00
Destination Charge	\$1,695.00
<b>Subtotal</b>	<b>\$41,980.00</b>

#### Pre-Tax Adjustments

Code	Description	
56M	GPC	-\$8,600.00

---

**Total** **\$33,380.00**

\_\_\_\_\_  
Customer Signature

\_\_\_\_\_  
Acceptance Date

Prices and content availability as shown are subject to change and should be treated as estimates only. Actual base vehicle, package and option pricing may vary from this estimate because of special local pricing, availability or pricing adjustments not reflected in the dealer's computer system. See salesperson for the most current information.



# Michael Hohl Motor Company

Jon L. Blakely | 775-378-2279 | jon.blakely@michaelhohl.com

*NEEDS  
5601*

**WATER**

## Carson City Public Works

**Prepared For:** Rich Hardcastle

775-283-7436

RHardcastle@carson.org

[Fleet] 2020 Chevrolet Silverado MD (CK56403) 4WD Reg Cab Work Truck



Please let me know if there are any changes needed to this quote.

Thanks

JB



# Michael Hohl Motor Company

Jon L. Blakely | 775-378-2279 | jon.blakely@michaelhohl.com

[Fleet] 2020 Chevrolet Silverado MD (CK56403) 4WD Reg Cab Work Truck (✔ Complete)

## Quote Worksheet

	<b>MSRP</b>
Base Price	\$51,400.00
Dest Charge	\$1,695.00
Total Options (Includes 11FT Truck Crane)	\$98,849.00
<b>Subtotal</b>	<b>\$151,944.00</b>
State bid asst	(\$7,500.00)
<b>Subtotal Pre-Tax Adjustments</b>	<b>(\$7,500.00)</b>
Less Customer Discount	(\$2,949.19)
<b>Subtotal Discount</b>	<b>(\$2,949.19)</b>
Trade-In	\$0.00
<b>Subtotal Trade-In</b>	<b>\$0.00</b>
<b>Taxable Price</b>	<b>\$141,494.81</b>
Tire Weight Tax	\$26.64
Sales Tax	\$0.00
<b>Subtotal Taxes</b>	<b>\$26.64</b>
DMV	\$28.75
<b>Subtotal Post-Tax Adjustments</b>	<b>\$28.75</b>
<b>Total Sales Price</b>	<b>\$141,550.20</b>

### Comments:

Please sign and return to jon.blakely@michael.hohl.com

Thanks You for the opportunity

\_\_\_\_\_  
Dealer Signature / Date

\_\_\_\_\_  
Customer Signature / Date

This document contains information considered Confidential between GM and its Clients uniquely. The information provided is not intended for public disclosure. Prices, specifications, and availability are subject to change without notice, and do not include certain fees, taxes and charges that may be required by law or vary by manufacturer or region. Performance figures are guidelines only, and actual performance may vary. Photos may not represent actual vehicles or exact configurations. Content based on report preparer's input is subject to the accuracy of the input provided.

Data Version: 11827. Data Updated: Sep 8, 2020 11:28:00 PM PDT.



# Michael Hohl Motor Company

Jon L. Blakely | 775-378-2279 | jon.blakely@michaelhohl.com

[Fleet] 2020 Chevrolet Silverado MD (CK56403) 4WD Reg Cab Work Truck (3) (✔ Complete)

## Weight Distribution

### SPECIFICATION SUMMARY

Model #	CK56403
Truck/Tractor	
Wheelbase (WB)	165 in
Cab to Axle (CA)	83.86 in
Cab to Body/Swing Clear (BOC)	3.0 in
Body Length	0.0 ft
Body Weight	0.0 lbs
Cargo Weight	0.00 lbs
Front GAWR	7500 lbs
Rear GAWR	15000 lbs
GVWR	22500.00 lbs

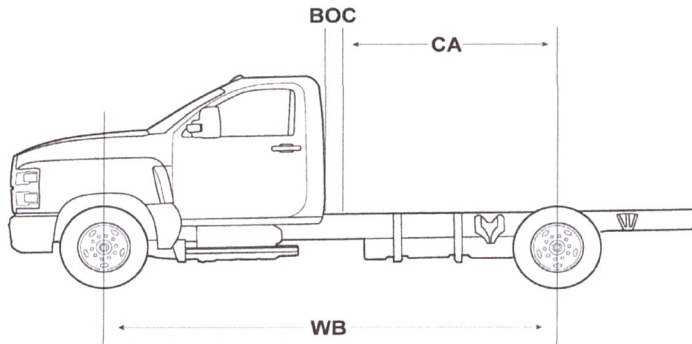

CA: 83.86 in  
 BOC: 3.0 in  
 WB: 165 in

<b>Fr%:</b> 65.06	<b>Rr%:</b> 34.94
<b>Front Wt:</b> 5838.00 lbs	<b>Rear Wt:</b> 3135.00 lbs

<b>GAWR/GVWR</b>	<b>GVW</b>	<b>Remaining Payload Wt</b>
22500.00 lbs	8973.00 lbs	13,527.00 lbs

This document contains information considered Confidential between GM and its Clients uniquely. The information provided is not intended for public disclosure. Prices, specifications, and availability are subject to change without notice, and do not include certain fees, taxes and charges that may be required by law or vary by manufacturer or region. Performance figures are guidelines only, and actual performance may vary. Photos may not represent actual vehicles or exact configurations. Content based on report preparer's input is subject to the accuracy of the input provided.  
 Data Version: 11827. Data Updated: Sep 8, 2020 11:28:00 PM PDT.

Prepared for: Rich Hardcastle

---

2021 F-150 4x4 SuperCab Styleside 8' box 163" WB XL (X1E)

**QTY 4-PARKS**

Price Level: 120

---



### **Client Proposal**

Prepared by:  
TIMOTHY SMITH  
Office: 775-882-5353  
Quote ID: 10120A  
Date: 10/01/2020





Prepared by: TIMOTHY SMITH  
10/01/2020

Capital Ford | 3660 South Carson Street Carson City Nevada | 897015579

2021 F-150 4x4 SuperCab Styleside 8' box 163" WB XL (X1E)

Price Level: 120 | Quote ID: 10120A

## Pricing Summary - Single Vehicle

		<b>MSRP</b>
<i>Vehicle Pricing</i>		
Base Vehicle Price		\$38,930.00
Options & Colors		\$2,145.00
Upfitting		\$0.00
Destination Charge		\$1,695.00
<b>Subtotal</b>		<b>\$42,770.00</b>
<i>Pre-Tax Adjustments</i>		
<b>Code</b>	<b>Description</b>	
56M	GPC	-\$9,400.00
<b>Subtotal</b>		<b>\$33,370.00</b>
<i>Discount Adjustments</i>		
Discount		-\$1,944.00
<b>Total</b>		<b>\$31,426.00</b>

\_\_\_\_\_  
Customer Signature

\_\_\_\_\_  
Acceptance Date

Prices and content availability as shown are subject to change and should be treated as estimates only. Actual base vehicle, package and option pricing may vary from this estimate because of special local pricing, availability or pricing adjustments not reflected in the dealer's computer system. See salesperson for the most current information.



---

2021 F-150 4x4 SuperCab Styleside 6.5' box 145" WB XL (X1E)

Price Level: 120

**PARK RANGER**

---



**Client Proposal**

Prepared by:

TIMOTHY SMITH

Office: 775-882-5353

Quote ID: 10820

Date: 10/08/2020



Capital Ford | 3660 South Carson Street, Carson City, Nevada, 897015579

Office: 775-882-5353 | Fax: 775-882-8071



Prepared by: TIMOTHY SMITH  
 10/08/2020

Capital Ford | 3660 South Carson Street Carson City Nevada | 897015579

2021 F-150 4x4 SuperCab Styleside 6.5' box 145" WB XL (X1E)

Price Level: 120 | Quote ID: 10820

Pricing Summary - Single Vehicle

		<b>MSRP</b>
<i>Vehicle Pricing</i>		
Base Vehicle Price		\$36,455.00
Options & Colors		\$2,945.00
Upfitting		\$0.00
Destination Charge		\$1,695.00
<b>Subtotal</b>		<b>\$41,095.00</b>
<i>Pre-Tax Adjustments</i>		
<b>Code</b>	<b>Description</b>	
56M	GPC	-\$9,400.00
Extra Keys	extra key	\$350.00
<b>Subtotal</b>		<b>\$32,045.00</b>
<i>Discount Adjustments</i>		
Discount		-\$1,854.53
<b>Total</b>		<b>\$30,190.47</b>

Customer Signature

Acceptance Date

Prices and content availability as shown are subject to change and should be treated as estimates only. Actual base vehicle, package and option pricing may vary from this estimate because of special local pricing, availability or pricing adjustments not reflected in the dealer's computer system. See salesperson for the most current information.

---

2021 F-550 Chassis 4x4 SD Super Cab 192" WB DRW XL (X5H)

Price Level: 115

**PARKS-DUMP TRUCK**

---



**Client Proposal**

Prepared by:  
TIMOTHY SMITH  
Office: 775-882-5353  
Quote ID: 111020  
Date: 11/10/2020





Prepared by: TIMOTHY SMITH  
11/10/2020

Capital Ford | 3660 South Carson Street Carson City Nevada | 897015579

2021 F-550 Chassis 4x4 SD Super Cab 192" WB DRW XL (X5H)

Price Level: 115 | Quote ID: 111020

## Pricing Summary - Single Vehicle

		<b>MSRP</b>
<i>Vehicle Pricing</i>		
Base Vehicle Price		\$46,855.00
Options & Colors		\$3,360.00
Upfitting		\$0.00
Destination Charge		\$1,695.00
<b>Subtotal</b>		<b>\$51,910.00</b>
<i>Pre-Tax Adjustments</i>		
<b>Code</b>	<b>Description</b>	
56M	GPC	-\$4,800.00
Scelzi Chipper	Chipper Truck	\$19,378.00
<b>Subtotal</b>		<b>\$66,488.00</b>
<i>Discount Adjustments</i>		
Discount		-\$3,060.01
<b>Total</b>		<b>\$63,427.99</b>

Customer Signature

Acceptance Date

Prices and content availability as shown are subject to change and should be treated as estimates only. Actual base vehicle, package and option pricing may vary from this estimate because of special local pricing, availability or pricing adjustments not reflected in the dealer's computer system. See salesperson for the most current information.

Prepared for: Rich Hardcastle

---

2021 Police Interceptor Utility AWD Base (K8A)

Price Level: 120

**Qty 2-ALT. SENTENCING**

---



**Client Proposal**

Prepared by:  
TIMOTHY SMITH  
Office: 775-882-5353  
Quote ID: 92120C  
Date: 10/07/2020



Prepared for: Rich Hardcastle



Prepared by: TIMOTHY SMITH

10/07/2020

Capital Ford | 3660 South Carson Street Carson City Nevada | 897015579

2021 Police Interceptor Utility AWD Base (K8A)

Price Level: 120 | Quote ID: 92120C

## Pricing Summary - Single Vehicle

**MSRP**

### Vehicle Pricing

Base Vehicle Price	\$40,630.00
Options & Colors	-\$3,345.00
Upfitting	\$0.00
Destination Charge	\$1,245.00

**Subtotal** \$38,530.00

### Pre-Tax Adjustments

Code	Description	
GPC Nevada		-\$3,450.00

**Subtotal** \$35,080.00

### Discount Adjustments

Discount	-\$1,208.00
----------	-------------

**Total** **\$33,872.00**

Customer Signature

Acceptance Date

Prices and content availability as shown are subject to change and should be treated as estimates only. Actual base vehicle, package and option pricing may vary from this estimate because of special local pricing, availability or pricing adjustments not reflected in the dealer's computer system. See salesperson for the most current information.



## Michael Hohl Motor Company

Jon L. Blakely | 775-378-2279 | jon.blakely@michaelhohl.com

# City of Carson Public Works

Prepared For: Rich Hardcastle

775-283-7436

rhardcastle@carson.org

[Fleet] 2021 Chevrolet Tahoe (CK10706) 4WD 4dr Commercial (4)



**QTY 5-SHERIFF**

Please let me know if there are any changes needed to this quote.

Thanks

JB



# Michael Hohl Motor Company

Jon L. Blakely | 775-378-2279 | jon.blakely@michaelhohl.com

[Fleet] 2021 Chevrolet Tahoe (CK10706) 4WD 4dr Commercial (4) (✔ Complete)

Quote: City of Carson SSV 2021 x5

## Quote Worksheet

	<b>MSRP</b>
Base Price	\$51,000.00
Dest Charge	\$1,295.00
Total Options	(\$3,059.00)
<b>Subtotal</b>	<b>\$49,236.00</b>
State Biod Asst	(\$7,250.00)
<b>Subtotal Pre-Tax Adjustments</b>	<b>(\$7,250.00)</b>
Less Customer Discount	(\$1,494.09)
<b>Subtotal Discount</b>	<b>(\$1,494.09)</b>
Trade-In	\$0.00
<b>Subtotal Trade-In</b>	<b>\$0.00</b>
<b>Taxable Price</b>	<b>\$40,491.91</b>
Sales Tax	\$0.00
<b>Subtotal Taxes</b>	<b>\$0.00</b>
DNV 30 Day Plate	\$29.25
<b>Subtotal Post-Tax Adjustments</b>	<b>\$29.25</b>
<b>Total Sales Price</b>	<b>\$40,521.16</b>

### Comments:

Please sign and return to jon.blakely@michael.hohl.com

This truck is a Fleet Order only

~~This is a Lennox Fleet Order Only #883333 ZKI~~

Thanks You for the opportunity

*Jon L Blakely*

10/06/2020

Dealer Signature / Date

Customer Signature / Date

This document contains information considered Confidential between GM and its Clients uniquely. The information provided is not intended for public disclosure. Prices, specifications, and availability are subject to change without notice, and do not include certain fees, taxes and charges that may be required by law or vary by manufacturer or region. Performance figures are guidelines only, and actual performance may vary. Photos may not represent actual vehicles or exact configurations. Content based on report preparer's input is subject to the accuracy of the input provided.

Data Version: 12021. Data Updated: Oct 4, 2020 11:43:00 PM PDT.



---

2020 Transit-350 Cargo AWD Medium Roof Van 148" WB Base (W2C)

Price Level: 40

**SHERIFF**

---



**Client Proposal**

Prepared by:  
TIMOTHY SMITH  
Office: 775-882-5353  
Quote ID: 110420  
Date: 11/04/2020





Prepared by: TIMOTHY SMITH  
11/04/2020

Capital Ford | 3660 South Carson Street Carson City Nevada | 897015579

2020 Transit-350 Cargo AWD Medium Roof Van 148" WB Base (W2C)

Price Level: 40 | Quote ID: 110420

## Pricing Summary - Single Vehicle

		<b>MSRP</b>
<i>Vehicle Pricing</i>		
Base Vehicle Price		\$43,830.00
Options & Colors		\$1,750.00
Upfitting		\$0.00
Destination Charge		\$1,695.00
<b>Subtotal</b>		<b>\$47,275.00</b>
<i>Pre-Tax Adjustments</i>		
<b>Code</b>	<b>Description</b>	
56M	GPC	-\$6,100.00
<b>Subtotal</b>		<b>\$41,175.00</b>
<i>Discount Adjustments</i>		
Discount		-\$2,294.04
<b>Total</b>		<b>\$38,880.96</b>

\_\_\_\_\_  
Customer Signature

\_\_\_\_\_  
Acceptance Date

Prices and content availability as shown are subject to change and should be treated as estimates only. Actual base vehicle, package and option pricing may vary from this estimate because of special local pricing, availability or pricing adjustments not reflected in the dealer's computer system. See salesperson for the most current information.

10/19/20



# CARSON CITY TOYOTA

## CAMPAGNI AUTO GROUP

2590 S. CARSON ST. CARSON CITY, NV 89701 CARSONCITYTOYOTA.COM 775-882-8211

3

October 19<sup>th</sup>, 2020

Please accept this quote for  
One 2021 Toyota Rav4 LE AWD 4x4  
Gas/ Electric Hybrid  
Model ~~4455~~ 4522  
Color White

1 - ASSESORS  
1 - DA  
1- HEALTH

Price	\$29,463.31	
State Title Fee	\$ 29.25	
Total	\$29,495.56	
Factory Rebate	<del>\$ 500.00</del>	\$750.00
Total	\$28,998.56	
1 Extra Key Programmed	\$ 359.49	
Total	<del>\$29,352.05</del>	\$29,102.05

Thank you for your business,

Dana Whaley

- Factory rebate good thru ~~November 4<sup>th</sup>, 2020.~~

December, 2020

10/19/20



# TOYOTA

## Carson City Toyota

2590 South Carson Street,  
Carson City, NV 89701  
(775) 882-8211

### 2021 RAV4 HYBRID LE AWD SUV

Model: 4522A  
 Year: 2021  
 Interior Color: BLACK  
 Exterior Color: SUPER WHITE  
 Number of Cylinders: 4  
 VIN: 2T3L6RFV6MW004218  
 Stock No.: 64221

Total MSRP\*:

\$30,259.00

41	CITY MPG	38	HWY MPG
----	-------------	----	------------

## Standard Equipment

### MECHANICAL & PERFORMANCE

- 2.5L 4-Cylinder Engine
- 219 Combined Net Horsepower
- Electronic Continuous Var. Tran. (ECVT)
- Electronic On-Demand All-Wheel Drive

### SAFETY & CONVENIENCE

- Toyota Safety Sense 2.0: Pre-Collision Sys w/ Pedestrian Detection, Full-Speed Range Dynamic Radar Cruise Control, Lane Departure Alert w/ Steering Assist, Lane Tracing Assist, Automatic High Beams, Road Sign Assist
- 8 Airbags; Star Safety System
- Backup Camera
- LATCH-Lower Anchor & Tether for Children
- Safety Connect w/ 1-Year Trial

### Optional Equipment

50 State Emissions	\$0.00
All Weather Floor Liners and Cargo Tray	\$269.00
Preferred Owner's Portfolio	\$0.00

### EXTERIOR

- LED Headlights
- LED Daytime Running Lights
- 17-in Five-Spoke Silver Alloy Wheels

### INTERIOR

- Audio - 7-in Touchscreen, 6 Speakers, HandsFree Bluetooth Phone/Music, USB Media Port, SiriusXM w/ 3-Month All Access Trial, Android Auto & Apple CarPlay Compatible
- Dual Zone Auto A/C w/ Rear Vents
- Fabric-Trimmed Seats
- Remote Keyless Entry
- For Full Product Details, Please Visit [Toyota.com/RAV4Hybrid](http://Toyota.com/RAV4Hybrid)

\*2021 Manufacturer's Suggested Retail Price, excludes the Delivery, Processing and Handling Fee, taxes, license, title and available or originally required equipment. Actual Dealer price may vary. Pricing, specifications, standard features and available equipment are based on information available when this page was produced and subject to change without notice.

Disclaimer: This document is only representative of some of the information contained on an actual window sticker, and is not meant to be a substitute for the actual window sticker on the vehicle. Please see your retailer for further information.

10/19/20



# TOYOTA

## Carson City Toyota

2590 South Carson Street,  
Carson City, NV 89701  
(775) 882-8211

### 2021 RAV4 HYBRID LE AWD SUV

Roof Rack Cross Bars	\$315.00
<b>Total Optional Equipment</b>	<b>\$584.00</b>
<b>Vehicle Base Model</b>	<b>\$28,500.00</b>
<b>Delivery Processing and Handling</b>	<b>\$1,175.00</b>
<b>Total MSRP*</b>	<b>\$30,259.00</b>

3

10/19/20



# CARSON CITY TOYOTA

## CAMPAGNI AUTO GROUP

2590 S. CARSON ST. CARSON CITY, NV 89701 CARSONCITYTOYOTA.COM 775-882-8211

2

October 19<sup>th</sup> 2020

**1-PURCHASING**

Please accept this quote for  
One 2021 Toyota Prius LE Sedan Gas/Electric Hybrid 4x4  
All Wheel Drive  
Model 1263  
Color White

Price	\$28,136.77
Rebate	<u>\$ 1,000.00</u>
Total	\$27,136.77
State Title Fee	<u>\$ 29.25</u>
Total	<b>\$27,166.02</b>

Includes 2 years or 25,000 miles service maintenance at no charge

\*Factory rebate good thru ~~November 4<sup>th</sup>~~, 2020  
December, 2020

Thank you for your business,

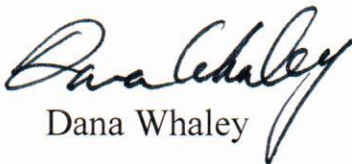
  
Dana Whaley

10/19/20



# TOYOTA

## Carson City Toyota

2590 South Carson Street,  
Carson City, NV 89701  
(775) 882-8211

### 2021 PRIUS LE AWD-E HYBRID

Model: 1263A  
 Year: 2021  
 Interior Color: Black  
 Exterior Color: Wind Chill Pearl  
 Number of Cylinders: 4  
 VIN: JTDL9MFU4M3023015  
 Stock No.: 63844

Total MSRP\*:

\$29,008.00

51	CITY MPG	47	HWY MPG
----	-------------	----	------------

## Standard Equipment

### MECHANICAL & PERFORMANCE

Hybrid Synergy Drive System, AT-PZEV  
 Electronic All-Wheel Drive System  
 1.8L DOHC 16V VVT-i 4-Cylinder Engine  
 EV/ECO/POWER Modes

### SAFETY & CONVENIENCE

10 Airbags; Star Safety System  
 Toyota Safety Sense 2.0: Pre-Collision  
 Sys w/Pedestrian Detection, Dynamic  
 Radar Cruise Control, Lane Departure  
 Alert w/Steering Assist,  
 Automatic High Beams, Road Sign Assist  
 BlindSpot Monitor w/Rear Cross  
 Traffic Alert  
 Intelligent Clearance Sonar  
 w/Intelligent Park Assist

### Optional Equipment

50 State Emissions	\$0.00
Special Color	\$425.00
All Weather Floor Liners/Cargo Liner	\$259.00

Smart Key System w/ Push Button Start

Safety Connect w/ 1-Year Trial

### EXTERIOR

Integrated Fog Lights, LED Accent Lights  
 Bi-LED Headlights w/Auto-Off, LED DRLs  
 Heated Power Outside Mirrors

### INTERIOR

Audio - 7-in Touchscreen, 6 Speakers,  
 HandsFree Bluetooth Phone/Music,  
 USB Media Port, 2 USB Charge-Ports,  
 SiriusXM w/3-Month All Access Trial  
 Android Auto & Apple CarPlay Compatible  
 Fabric-Trimmed Seats  
 60/40 Split Folding Rear Seat  
 Tire Repair Kit

\* 2021 Manufacturer's Suggested Retail Price, excludes the Delivery, Processing and Handling Fee, taxes, license, title and available or regionally required equipment. Actual Dealer price may vary. Pricing, specifications, standard features and available equipment are based on information available when this page was produced and subject to change without notice.

Disclaimer: This document is only representative of some of the information contained on an actual window sticker, and is not meant to replace or substitute for the actual window sticker on the vehicle. Please see your retailer for further information.

10/19/20



# TOYOTA

## Carson City Toyota

2590 South Carson Street,  
Carson City, NV 89701  
(775) 882-8211

### 2021 PRIUS LE AWD-E HYBRID

Door Edge Guards	\$125.00
Preferred Owner's Portfolio	\$0.00
Rear Bumper Applique	\$69.00
<b>Total Optional Equipment</b>	<b>\$878.00</b>
<b>Vehicle Base Model</b>	<b>\$27,135.00</b>
<b>Delivery Processing and Handling</b>	<b>\$995.00</b>
<b>Total MSRP*</b>	<b>\$29,008.00</b>





# MICHAEL HOHL MOTORS

TERRY ROUDA | 806-474-6654 | terry.rouda@michaelhohl.com

**QTY 2 - JV PROBATION**

## City of Carson City

**Prepared For:** Rich Hardcastle

775-283-7486

rhardcastle@carson.org

Vehicle: [Fleet] 2021 Chevrolet Traverse (1NV56) AWD 4dr LS w/1FL





# MICHAEL HOHL MOTORS

TERRY ROUDA | 806-474-6654 | terry.rouda@michaelhohl.com

Vehicle: [Fleet] 2021 Chevrolet Traverse (1NV56) AWD 4dr LS w/1FL (✔ Complete)

Quote: New Quote 21 traverse ls carson city

## Quote Worksheet

	<b>MSRP</b>
Base Price	\$35,900.00
Dest Charge	\$1,195.00
Total Options	\$0.00
<b>Subtotal</b>	<b>\$37,095.00</b>
Title transfer	\$29.25
GM State bid assistance	(\$6,700.00)
State of Nevada 1% admin fee	\$285.69
<b>Subtotal Pre-Tax Adjustments</b>	<b>(\$6,385.06)</b>
Less Customer Discount	(\$2,108.00)
<b>Subtotal Discount</b>	<b>(\$2,108.00)</b>
Trade-In	\$0.00
<b>Subtotal Trade-In</b>	<b>\$0.00</b>
<b>Taxable Price</b>	<b>\$28,601.94</b>
Sales Tax	\$0.00
<b>Subtotal Taxes</b>	<b>\$0.00</b>
<b>Subtotal Post-Tax Adjustments</b>	<b>\$0.00</b>
<b>Total Sales Price</b>	<b>\$28,601.94</b>

### Comments:

Rich Here is the quote for the 21 Traverse LS. It was the same, except I took out the doc fee, so it came out a little less.

\_\_\_\_\_  
Dealer Signature / Date

\_\_\_\_\_  
Customer Signature / Date

This document contains information considered Confidential between GM and its Clients uniquely. The information provided is not intended for public disclosure. Prices, specifications, and availability are subject to change without notice, and do not include certain fees, taxes and charges that may be required by law or vary by manufacturer or region. Performance figures are guidelines only, and actual performance may vary. Photos may not represent actual vehicles or exact configurations. Content based on report preparer's input is subject to the accuracy of the input provided.

Data Version: 12364. Data Updated: Nov 15, 2020 11:45:00 PM PST.

BM  
REPLACES  
H001

**BUILDING MAINT.**

---

2020 Transit-150 Cargo AWD Low Roof Van 148" WB Base (E2Y)

Price Level: 40

---



**Client Proposal**

Prepared by:  
TIMOTHY SMITH  
Office: 775-882-5353  
Quote ID: 1072020  
Date: 10/07/2020





Prepared by: TIMOTHY SMITH  
10/07/2020

Capital Ford | 3660 South Carson Street Carson City Nevada | 897015579

## 2020 Transit-150 Cargo AWD Low Roof Van 148" WB Base (E2Y)

Price Level: 40 | Quote ID: 1072020

### Pricing Summary - Single Vehicle

**MSRP**

#### Vehicle Pricing

Base Vehicle Price	\$40,480.00
Options & Colors	\$2,040.00
Upfitting	\$0.00
Destination Charge	\$1,695.00
<b>Subtotal</b>	<b>\$44,215.00</b>

#### Pre-Tax Adjustments

Code	Description	
56M	GPC	-\$8,300.00
<b>Subtotal</b>		<b>\$35,915.00</b>

#### Discount Adjustments

Discount	-\$2,155.31
----------	-------------

---

**Total** **\$33,759.69**

\_\_\_\_\_  
Customer Signature

\_\_\_\_\_  
Acceptance Date

Prices and content availability as shown are subject to change and should be treated as estimates only. Actual base vehicle, package and option pricing may vary from this estimate because of special local pricing, availability or pricing adjustments not reflected in the dealer's computer system. See salesperson for the most current information.

---

2021 F-350 Chassis 4x4 SD Super Cab 168" WB SRW XL (X3F)

Price Level: 115

**BUILDING MAINT.**

---



**Client Proposal**

Prepared by:  
TIMOTHY SMITH  
Office: 775-882-5353  
Quote ID: 100620B  
Date: 10/12/2020





Prepared by: TIMOTHY SMITH  
10/12/2020

Capital Ford | 3660 South Carson Street Carson City Nevada | 897015579

2021 F-350 Chassis 4x4 SD Super Cab 168" WB SRW XL (X3F)

Price Level: 115 | Quote ID: 100620B

## Pricing Summary - Single Vehicle

		<b>MSRP</b>
<i>Vehicle Pricing</i>		
Base Vehicle Price		\$40,910.00
Options & Colors		\$2,575.00
Upfitting		\$0.00
Destination Charge		\$1,695.00
<b>Subtotal</b>		<b>\$45,180.00</b>
<i>Pre-Tax Adjustments</i>		
<b>Code</b>	<b>Description</b>	
56M	GPC	-\$6,600.00
1142	Service Bed	\$9,396.00
<b>Subtotal</b>		<b>\$47,976.00</b>
<i>Discount Adjustments</i>		
Discount		\$0.00
<b>Total</b>		<b>\$47,976.00</b>

\_\_\_\_\_  
Customer Signature

\_\_\_\_\_  
Acceptance Date

Prices and content availability as shown are subject to change and should be treated as estimates only. Actual base vehicle, package and option pricing may vary from this estimate because of special local pricing, availability or pricing adjustments not reflected in the dealer's computer system. See salesperson for the most current information.



## Michael Hohl Motor Company

Jon L. Blakely | 775-378-2279 | jon.blakely@michaelhohl.com

**SHERIFF-DONATION**

# Carson City Sheriff

**Prepared For: Craig Lowe**

775-887-2500

CLowe@carson.org

[Fleet] 2021 Chevrolet Tahoe (CK10706) 4WD 4dr Commercial



Please let me know if there are any changes needed to this quote.

Thanks

JB



# Michael Hohl Motor Company

Jon L. Blakely | 775-378-2279 | jon.blakely@michaelhohl.com

[Fleet] 2021 Chevrolet Tahoe (CK10706) 4WD 4dr Commercial (✔ Complete)

Quote: Carson City Sheriff

## Quote Worksheet

	<b>MSRP</b>
Base Price	\$51,000.00
Dest Charge	\$1,295.00
Total Options	(\$9.00)
<b>Subtotal</b>	<b>\$52,286.00</b>
State Bid Asst 116734@84	(\$7,250.00)
<b>Subtotal Pre-Tax Adjustments</b>	<b>(\$7,250.00)</b>
Less Customer Discount	\$0.00
<b>Subtotal Discount</b>	<b>\$0.00</b>
Trade-In	\$0.00
<b>Subtotal Trade-In</b>	<b>\$0.00</b>
<b>Taxable Price</b>	<b>\$45,036.00</b>
Sales Tax	\$0.00
<b>Subtotal Taxes</b>	<b>\$0.00</b>
Dealer Doc	\$399.50
DMV 30 Plate	\$29.25
<b>Subtotal Post-Tax Adjustments</b>	<b>\$428.75</b>
<b>Total Sales Price</b>	<b>\$45,464.75</b>

### Comments:

Please sign and return to jon.blakely@michael.hohl.com

This truck is a Fleet Order only

Thanks You for the opportunity

\_\_\_\_\_  
Dealer Signature / Date

\_\_\_\_\_  
Customer Signature / Date

This document contains information considered Confidential between GM and its Clients uniquely. The information provided is not intended for public disclosure. Prices, specifications, and availability are subject to change without notice, and do not include certain fees, taxes and charges that may be required by law or vary by manufacturer or region. Performance figures are guidelines only, and actual performance may vary. Photos may not represent actual vehicles or exact configurations. Content based on report preparer's input is subject to the accuracy of the input provided.

Data Version: 11947. Data Updated: Sep 24, 2020 10:08:00 PM PDT.



**FIRE DEPT. FUELS-  
DONATION**

---

2021 F-350 4x4 SD Crew Cab 8' box 176" WB SRW XL (W3B)

Price Level: 115

---



**Client Proposal**

Prepared by:  
TIMOTHY SMITH  
Office: 775-882-5353  
Quote ID: 100620A  
Date: 10/06/2020





Prepared by: TIMOTHY SMITH  
10/06/2020

Capital Ford | 3660 South Carson Street Carson City Nevada | 897015579

2021 F-350 4x4 SD Crew Cab 8' box 176" WB SRW XL (W3B)

Price Level: 115 | Quote ID: 100620A

## Pricing Summary - Single Vehicle

	<b>MSRP</b>
<i>Vehicle Pricing</i>	
Base Vehicle Price	\$42,345.00
Options & Colors	\$4,765.00
Upfitting	\$0.00
Destination Charge	\$1,695.00
<i>Discount Adjustments</i>	
Discount	-\$2,546.00
<b>Total</b>	<b>\$46,259.00</b>

Customer Signature

Acceptance Date



128859-01

November 13, 2020

CARSON CITY PUBLIC WORKS

3505 BUTTI WAY  
CARSON CITY, Nevada 89701-3498

**FIRE DEPT. FUELS-  
DONATION**

Dear Mr. Hardcastle,

Thank you for this opportunity to quote Caterpillar products for your business needs. We are pleased to quote the following for your purchase consideration.

One (1) New Cat Model: 299D3XE C Compact Track Loader with all standard equipment in addition to the additional specifications listed below:

**STOCK NUMBER:** CE011776

**SERIAL NUMBER:** 0BX902082

**YEAR:** 2020

**SMU:** 0

Thank you for your interest in Cashman Equipment and Caterpillar products for your business needs. Our goal is to be a value added partner in your success. This quotation is valid for 30 days, after which time we reserve the right to re-quote. If there are any questions, please do not hesitate to contact me.

Sincerely,

Paul Murphy  
Machine Sales Representative  
Cashman Equipment Company  
PaulDMurphy@cashmanequipment.com  
775-842-3890

**One (1) New Cat Model: 299D3XE C Compact Track Loader with all standard equipment in addition to the additional specifications listed below:**

**STANDARD EQUIPMENT**

**POWERTRAIN** -Cat C3.8 turbo aftercooled diesel engine --Gross horsepower per SAE J1349 -110 hp (82 kW) @ 2400 RPM --Electric fuel priming pump --Air inlet heater starting aid --Liquid cooled, direct injection -Air cleaner, dual element, radial seal -S-O-S sampling valve, hydraulic oil -Filter, cartridge type, hydraulic -Filters, canister type, fuel -and water separator -Radiator/hydraulic oil -cooler (side-by-side) -Spring applied, hydraulically released, -wet multi disc parking brakes -Hydrostatic transmission

**UNDERCARRIAGE** -Triple flange idler - front and rear -Suspension - independent torsion axle(4) -Two speed travel with ride control -

**HYDRAULICS** -High flow: 40 gpm (150 lpm) max -High flow Pressure: 4061 psi -28000 kPa max -Continuous flow -Hydraulics, proportional -Worktool harness -CONTROLS: -Electro/hydraulic implement control -Electro/hydraulic hydrostatic -Transmission control -Speed Sensor Guarding -

**STARTERS, BATTERIES, & ALTERNATORS** -1000 CCA heavy duty battery w/disconnect -

**ELECTRICAL** -12 Volt electrical system -100 ampere alternator -Ignition key start / stop / aux switch -Lights: --Gauge backlighting --Two rear tail lights --Dome light -Backup alarm -Electrical outlet, beacon -

**OPERATOR ENVIRONMENT** -Operator warning system indicators: --Air filter restriction --Alternator output --Armrest raised / operator out of seat --Engine coolant temperature --Engine oil pressure --Air inlet heater activation --Hydraulic filter restriction --Hydraulic oil temperature --Park brake engages --Engine emission system -Gauges: DEF level, fuel level, -hour meter and tachometer -Storage compartment with netting -Seat, comfort, air suspension, cloth, -heat --High back heated seat with recline --Lumbar support --Fully adjustable seat mounted -controls -Ergonomic contoured armrest -Control interlock system, when operator -leaves seat or armrest raised : --Hydraulic system disables --Hydrostatic transmission disables --Parking brake engages -ROPS, Cab, enclosed (C3), tilt up: --Air conditioner incl heater/defroster --Side windows --Cup holder -FOPS, Level I -Top and rear windows -Deluxe headliner -Floor mat -Interior rear view mirror -12V Electric socket -Horn -Hand (dial) & foot throttle, electronic -Dual direction electronic self level - -(raise and lower) -Work tool return to dig -Work tool positioner -Electronic snubbing (lift) -Advanced LCD display --Full color 5 inch LCD screen --Advanced anti-theft security system -with 50 user code capability --Rear view camera

**FRAMES** -Lift linkage, vertical path -Chassis, one piece welded -Machine tie down points (6) -Belly pan cleanout -Support, lift arm -Cast rear bumper -Ventilated rear door with integrated -sealing

**OTHER STANDARD EQUIPMENT** -Engine enclosure - lockable -Extended life antifreeze (-37C, -34F) -Work tool coupler -Hydraulic oil level sight gauge -Radiator coolant level sight gauge -Radiator expansion bottle -Cat ToughGuard TM hose -Heavy duty quick disconnects with -integrated pressure release -Split d-ring to route work tool hoses -along side of left lift arm -Variable speed hydraulic cooling fan -Per SAE J818-2007 and EN 474-3:2006 and -ISO 14397-1:2007

**MACHINE SPECIFICATIONS**

299D3 XE COMPACT TRACK LOADER	512-4300
DEBRIS MGMT PKG, NONE (DM0)	512-3467
TRACK,RUBBER,400MM(15.7IN)BLCK	389-7673
FILM, SELF LEVEL, ANSI	435-9238
FILM, RIDE CONTROL, ANSI	422-3445
REAR LIGHTS	356-6082
SEAT BELT, 3"	542-6995
CERTIFICATION ARR, P65	563-1163
INSTRUCTIONS, ANSI, USA	512-4284
SERIALIZED TECHNICAL MEDIA KIT	421-8926
SHIPPING/STORAGE PROTECTION	0P-2266
HEATER, ENGINE COOLANT, 120V	345-3556
PACK, DOMESTIC TRUCK	0P-0210
CAB PACKAGE, ULTRA	588-9141
FAN,COOLING, DEMAND, REVERSING	579-8782
RADIO, AM/FM, BLUETOOTH	345-6180
LIGHTS, LED	495-1671
RUBBER BELT, 2 SPD, TF IDLERS	512-3929
PRODUCT LINK, CELLULAR PL243	566-7115
QUICK COUPLER, HYDRAULIC	512-3401
DOOR, CAB, GLASS	586-1307
LANE 3 ORDER	0P-9003
SLL3475	ENG SE-RIAL
KUBOTA	ENG -MAKE
C3.8	ENG M-ODEL
LKBXL03.8AMD	ENG FA-MILY
2020	ENG -YEAR
3.8L	DISPLACEMENT
109.69	HORSEPOWER
KIT, COOLER, AUXILIARY HYDR - CE015544Z	4518378
KIT, FUEL TANKS, EXTERNAL	548-3166
BUCKET-GP, 80", BOCE	279-5377
Fire Suppression Sytem	

**WARRANTY & COVERAGE**

Standard Warranty: 24 month/2000 hour \*All standard warranties include travel time & mileage for first twelve months. Scheduled Oil sampling is required during entire warranty period. Travel time & mileage is not included during the standard warranty period on Cat utility vehicles (UTVs).

Extended Coverage: 299-36 MO/3000 HR POWERTRAIN + HYDRAULICS + TECH (Tier 4)

---

SALES PRICE	\$113,561.11
<b>SUBTOTAL</b>	<b>\$113,561.11</b>
EXTENDED COVERAGE	Included
<b>GRAND TOTAL</b>	<b>\$113,561.11</b>

---

**F.O.B/TERMS:**  
Delivered to Customer

Accepted by \_\_\_\_\_ on \_\_\_\_\_

\_\_\_\_\_  
Signature