

PLAN VIEW
NTS

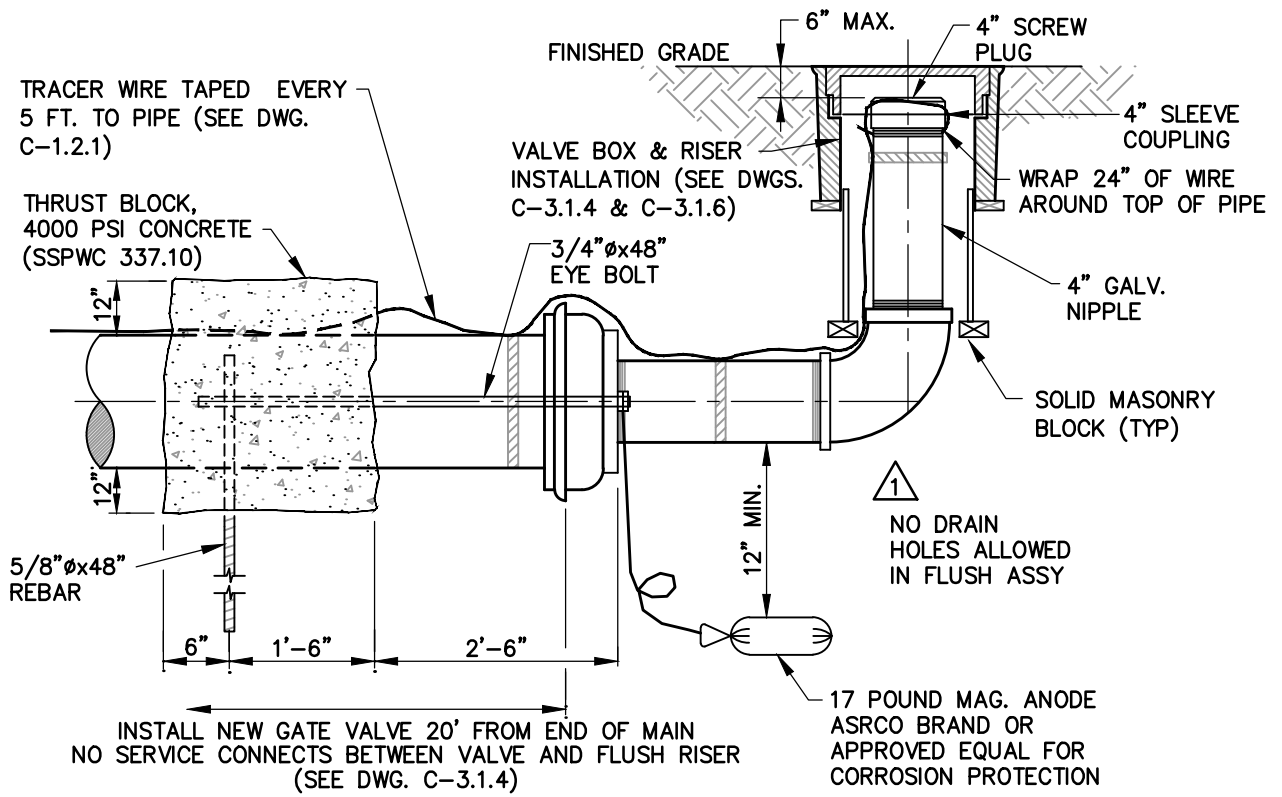

SECTION A-A
NTS

NO.			REVISION			DATE			STANDARD DETAIL FOR PUBLIC WORKS CONSTRUCTION			SECTION		
1			REMOVE DRAIN			3/22			FLUSH ASSEMBLY TEMPORARY			CARSON CITY		
												DRAWING NO. C-3.1.13		
												DATE MAR 2022		
APPROVED BY:						3/22								