

**MANHOLE ADJUSTMENT
TYPICAL SECTION**
NTS

1-1/4"x1"x1/4"
ANGLE IRON x 6" LONG
(4 PLACES, TYP.)

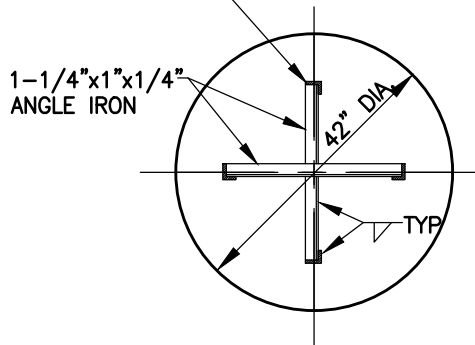

SECTION A-A
NTS

3/8" STEEL PLATE
TEMP. COVER (SEE
NOTE 1.)

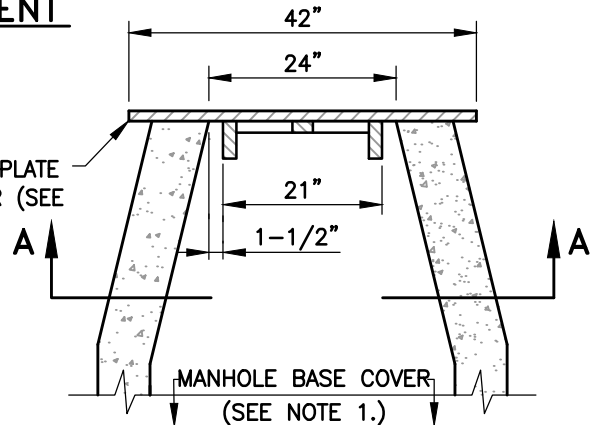

**TEMPORARY COVER
TYPICAL SECTION**
NTS

NOTES:

1. INSTALL TEMPORARY COVER WITH CONE INSTALLATION WHEN INSTALLING NEW MANHOLE OR PRIOR TO REMOVING EXISTING FRAME & COVER AND GRADE RINGS TO ADJUST TO FINISH GRADE. INSTALL COVER OVER MANHOLE BASE TO PREVENT DEBRIS FROM ENTERING SEWER SYSTEM. THE MANHOLE BASE COVER SHALL BE IN PLACE PRIOR TO PERFORMING ANY ADJUSTMENTS OR GROUTING AND SHALL REMAIN IN PLACE WHILE ADJUSTMENTS OR GROUTING ARE BEING PERFORMED. REMOVE BASE COVER UPON ADJUSTMENT APPROVAL BY CARSON CITY.
2. CONCRETE SHALL CONFORM TO THE SSPWC SECTION 202.01.12. REBAR SHALL BE USED ONLY WHEN THE MANHOLE IS LOCATED OUTSIDE PAVED AREAS.
3. THE CONCRETE COLLAR SHALL BE LEFT 2 1/2 INCHES TO 3 INCHES BELOW FINISHED ASPHALT SURFACE. APPLY AN APPROVED TACK COAT (CONFORMING TO THE SSPWC SECTION 316) AND FILL VOID BETWEEN ADJACENT PAVEMENT AND FRAME WITH TYPE 3 AC 20 PAVING (CONFORMING TO THE SSPWC SECTION 320). APPLY FOG SEAL (CONFORMING TO SSPWC SECTION 317) TO THE ASPHALT SURFACE. ALL CUTS IN PAVING SHALL BE STRAIGHT AND EVEN. EXCEPTION: WHEN STRUCTURE NOT LOCATED IN ASPHALT PAVEMENT OR LOCATED IN AN UNPAVED AREA, EXTEND CONCRETE TO FINISH GRADE.
4. INSTALL NEW FRAME & COVER UNLESS OTHERWISE SHOWN ON THE PLANS OR SPECIAL CONDITIONS. FRAME & COVER SHALL BE SET FLUSH WITH FINISH GRADE UNLESS OTHERWISE NOTED.
5. FOR NEW MANHOLE INSTALLATIONS, DISTANCE FROM COVER TO CONE SHALL BE 12 INCHES MINIMUM AND 24 INCHES MAXIMUM. FOR ADJUSTING EXISTING FRAME & COVERS THE DISTANCE FROM COVER TO CONE SHALL NOT EXCEED 24 INCHES. 
6. WHEN LOCATED IN NDOT RIGHT-OF-WAY, CONCRETE COLLAR SHALL CONFORM TO NDOT STANDARD PLAN SHT R-4.7.3 AND STANDARD SPECIFICATION 609.

NO.	REVISION	DATE	STANDARD DETAIL FOR PUBLIC WORKS CONSTRUCTION	SECTION CARSON CITY
	RISER DEPTH	3/22	MANHOLE FRAME & COVER ADJUSTMENT	DRAWING NO. C-2.1.5 (204, 323)
				DATE MAR 2022
APPROVED BY:		3/22		